



**ERSATZTEILLISTE**

**SPARE PARTS LIST**

**LISTE DES PIECES  
DE RECHANGE**

**LISTINO RICAMBI**

**LISTA DE RECAMBIOS**

**WYKAZ CZESCI  
ZAMIENNYCH**



**CF 2**  
**010061-010063**

10.2005

Weber Maschinenteknik GmbH  
Postfach 2153, 57329 Bad Laasphe-Rückershausen  
Telefon 02754 / 398-0  
Telefax (02754) 398-101 (Zentrale) u. 398-102 (Ersatzteile)

## EG - KONFORMITÄTSEKTLÄRUNG

EC DECLARATION OF CONFORMITY / DECLARATION DE CONFORMITE CE  
DICHIARAZIONE CE DI CONFORMITA / DECLARACION CE DE CONFORMIDAD  
EG-VERKLARING VAN OVEREENSTEMMING / EF-OVERENSSTEMMELSESEKTLÄRUNG  
DECLARACAO CE DE CONFORMIDADE / EG-FÖRSÄKRAN OM ÖVERENSSTÄMMELSE  
DEKLARACJA ZGODNOŚCI

### im Sinne der EG-Maschinenrichtlinie 98/37/EG und der EG Richtlinie 2000/14/EG - Geräuschemissionen

- I **Art / Category / Catégorie / Categoria Tipo / Kategori /**  
Soort / Categoria / kategori / Typ
- II **Hersteller (Typ) / Make (Type) / Marque (Type) / Marca (Tipo) /**  
Marca (Codice) / Producent (Type) / Merk (Type) / Marca (Tipo) /  
Tillverkare (Typ) / Producent
- III **Nennleistung / Nominal-performance / La puissance nominale / Prestazione nominale /**  
Potencia nominal / Nominaal vermogen / Nominel ydelse / Potência nominal / Nominell  
effect / Moc
- IV **gemessener Schalleistungspegel / measured sound power level / niveau de**  
puissance acoustique mesure / livello di potenza sonora rilevato / nivel de potencia  
acústica medido / gemeten geluidsvermogensniveau / målt lydeffektniveau / Nivel de  
potência sonora midido / uppmätt ljudeffektnivå / Mierzony poziom dźwięku
- V **garantierter Schalleistungspegel / guaranteed sound power level / niveau de**  
puissance acoustique garanti / livello di potenza sonora garantito / nivel de potencia  
acustica garantizado / gewaarborgd geluidsvermogensniveau / garanteret lydeffektniveau /  
Nivel sonoro garantido / garanterad ljudeffektnivå / Natężenie hałas
- VI **beteiligte Zertifizierungsstelle / notified body involved / de l'organisme notifié /**  
dell'organismo notificato che l'ha effettuata / dirección del organismo notificado que haya  
intervenido / betrokken aangemelde instantie / pagældende bemyndigede organ /  
organismo notificado envolvido / berörda anmälda organets namn / Jednostka  
certyfikująca
- VII **Konformitäts-Bewertungsverfahren / Conformity assessment procedure followed /**  
la procédure appliquée pour l'évaluation de la conformité et / procedura di valutazione  
della conformità / procedimiento de evaluación de la conformidad / gevolgde  
overeenstemmingsbeoordelingsprocedure / den fulgte  
overensstemmelsesvurderingsprocedure / procedimento de avaliacao de conformidade  
/ Vilket förfarande för bedömning av överensstämmelse / Przebieg kontroli

Vibrationsplatte  
CF 2



P = 2,6 / 4,0 kW

LWA = 102 dB (A)

LWA = 105 dB (A)

RWTÜV  
Postfach 103161  
D-45032 Essen

interne Fertigungskontrolle  
nach Anhang VI  
EG Richtlinie 2000/14/EG

**ist in Übereinstimmung mit folgenden Richtlinien hergestellt worden / has been produced in accordance with following standards / est produit conforme aux dispositions des directives europeenes ci-apres / ha sido fabricado en conformidad con las siguientes normas / é stato fabbricato in conformità alle sequenti norme / er blevet fremstillet i overensstemmelse med følgende retningslinier / in overeenstemming met de volgende voorschriften gefabriceerd is / é fabricado conforme as seguintes normas / har tillverkats i överensstämmelse med följande riktlinjer / Zgodność z obowiązującymi przepisami**

**98/37/EG** Maschinenrichtlinie des europäischen Parlamentes und des Rates vom 22. Juni 1998  
**2000/14/EG** EG-Richtlinie Geräuschemissionen vom 8. Mai 2000  
**EN 500 Teil 1** Bewegliche Straßenbaumaschinen – Sicherheit  
Gemeinsame Anforderungen  
**EN 500 Teil 4** Bewegliche Straßenbaumaschinen – Sicherheit  
Besondere Anforderungen an Verdichtungsmaschinen

**Bescheinigung bitte sorgfältig aufbewahren / File certificate carefully / Conserver certificat soigneusement / Conservar certificado cuidadosamente / Pregasi conservare accuratamente certificato / Beviset bedes opbevares omhyggeligt / Verklaring a.u.b. zorgvuldig bevar / Conservar o certificado com cuidado / Beviset skall om sorgfullt bevaras // Deklarację zgodności proszę zachować**

Bad Laasphe – Rückershausen, den **02.01.2004**

  
W. Weber, Geschäftsführer

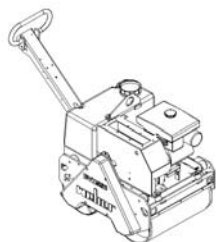

**WEBER Maschinentechnik GmbH**

Im Boden 5-8, 10 – D-57334 Bad Laasphe  
Postfach 2153 – D-57329 Bad Laasphe  
Telefon: 02754/398-0 – Fax 02754/398-101  
E-mail: [Verkauf@webermt.de](mailto:Verkauf@webermt.de)  
Internet: <http://www.webermt.de>



BITTE, NOTIEREN SIE SERIENNUMMER UND MOTORNUMMER IHRER MASCHINE:

PLEASE WRITE DOWN SERIALNUMBERS OF MACHINE AND ENGINE:

NOTEZ SVP LE NUMERO DE SERIE ET LE NUMERO DU MOTEUR DE VOTRE MACHINE:

SI PREGA DI ANNOTARE SEMPRE I NUMERI DI SERIE SIA DELLA VS. MACCHINA CHE DEL MOTORE:

MAQUINA: ROGAMOS ANOTEN EL NUMERO DE SERIE Y NUMERO DE MOTOR DE SU MAQUINA:

MASCHINE  
MACHINE  
MACCHINA  
MAQUINA

# # #
-------------

MOTOR  
ENGINE  
MOTEUR  
MOTORE

# # #
-------------

ZUR VERMEIDUNG VON FEHLLIEFERUNGEN UND VERZÖGERUNGEN SIND BEI DER BESTELLUNG VON ERSATZTEILEN FOLGENDE ANGABEN UNBEDINGT ERFORDERLICH:

- MASCHINENTYP
- SERIENNUMMER DER MASCHINE
- SERIENNUMMER DES MOTORS (BEI MOTORTEILEN)
- TEILENUMMER
- BESTELLMENGE

TO AVOID ERRORS IN DELIVERY PLEASE STATE THESE PARTICULARS WHEN ORDERING:

- TYPE OF MACHINE
- SERIAL NO. OF MACHINE
- SERIAL NO. OF ENGINE (ON ENGINE PARTS)
- PART-NO.
- QUANTITY REQUIRED

AFIN D'EVITER DES ERREURS DE COMMANDE ET DES RETARDS DE LIVRAISON IL EST NECESSAIRE D'INDIQUER LES CARACTERISTIQUES SUIVANTES:

- TYPE DE MACHINE
- LE NUMERO DE SERIE DE LA MACHINE
- LE NUMERO DE SERIE DU MOTEUR
- LE NUMERO D'IDENTITE DE LA PIECE
- LA QUANTITE SOUHAITEE

ONDE EVITARE DISGUIDI E RITARDI NELLE CONSEGNE DIE RICAMBI SI PREGA DI INDICARE SEMPRE:

- TIPO DELLA MACCHINA
- NUMERO DI SERIE DELLA MACCHINA
- NUMERO DI SERIE DEL MOTORE (SE SI RICHIEDONO PEZZI DEL MOTORE)
- NUMERO D'ORDINE DIE SINGOLI RICAMBI
- QUANTITA

A FI DE EVITAR ERRORES DE ENTREGA, ROGAMOS INDIQUEN LOS SIGUIENTES DATOS CUANDO PASE PEDIDOS DE RECAMBIO:

- MODELO DE MAQUINA
- NO. DE SERIE DE LA MAQUINA
- NO. DE SERIE DEL MOTOR (EN PIEZAS PARA MOTOR)
- REFERENCIA DEL RECAMBIO
- CANTIDAD PEDIDA

## E 3048-0702

Position Ref.No. Repère Posizione Posicion	Menge Quantity Quantité Quantita Cantidad	Teile-Nr. Part-No. No. Référence Nr. d'Ordine No. Referenzia	Hinweis Hints Indications Indicazione Indicaciones	Position Ref. No. Repère Posizione Posicion	Menge Quantity Quantité Quantita Cantidad	Teile-Nr. Part-No. No. Référence Nr. d'Ordine No. Referenzia	Hinweis Hints Indications Indicazione Indicaciones
1	1	10022225					
2	4	20004039					
3	4	25049020	DIN7349-10,5				
4	4	20029001	VSK 10				
5	4	25031028	DIN1587-M10				
6	4	20029022	SKB 10				
7	4	25031004	DIN934-M10				
8	1	10001412					
9	2	25044027	DIN912-M12x45				
10	2	25044104	DIN912-M12x40				
11	4	20029013	VSKZ 12				

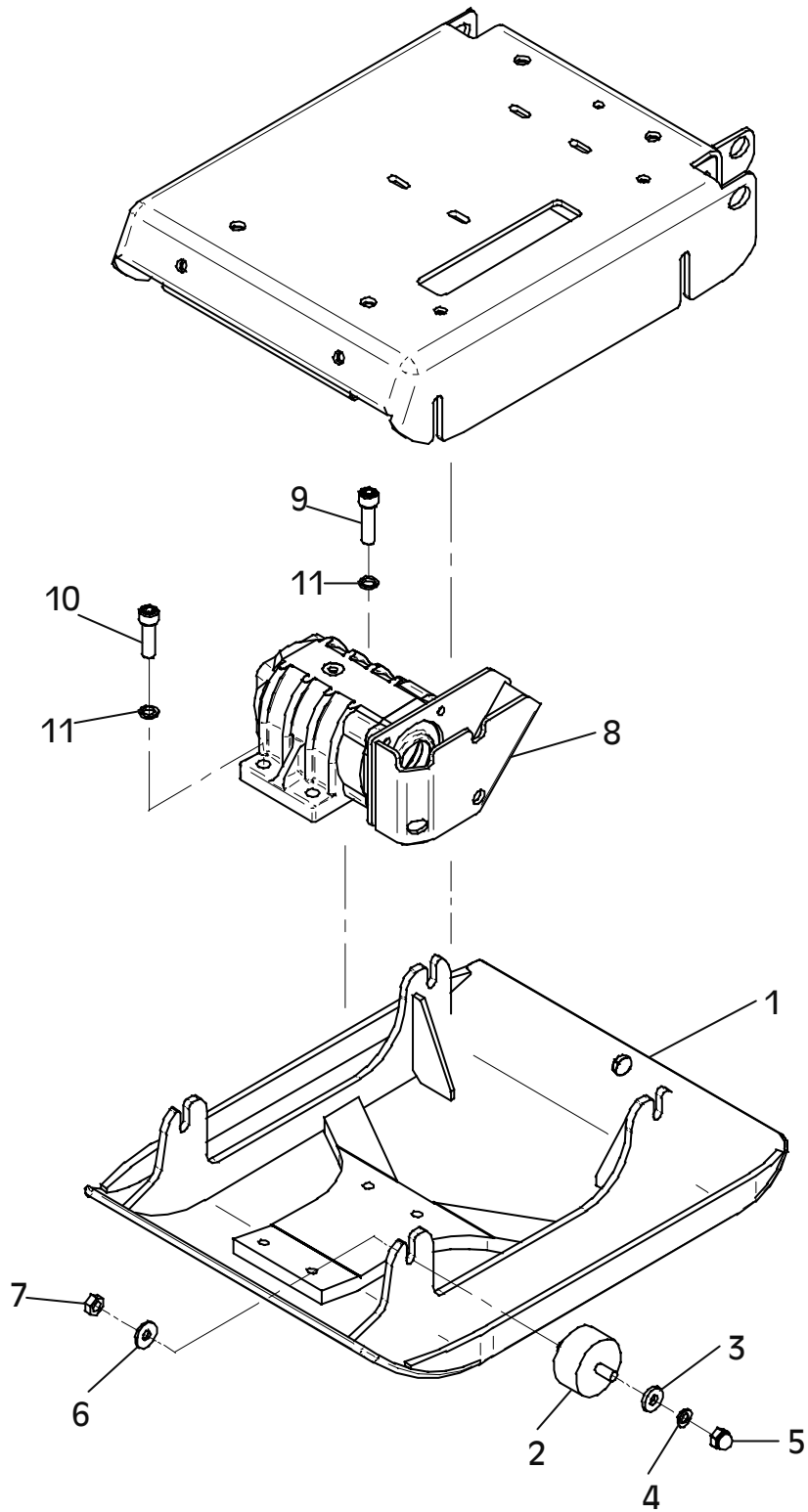

E 3048-0702

## E 3049-0702

Position Ref.No. Repère Posizione Posicion	Menge Quantity Quantité Quantita Cantidad	Teile-Nr. Part-No. No. Référence Nr. d'Ordine No. Referenzia	Hinweis Hints Indications Indicazione Indicaciones	Position Ref. No. Repère Posizione Posicion	Menge Quantity Quantité Quantita Cantidad	Teile-Nr. Part-No. No. Référence Nr. d'Ordine No. Referenzia	Hinweis Hints Indications Indicazione Indicaciones
1	1	10009615					
2	1	25030001	DIN908-M10x1				
3	1	20025811					
4	1	10016090					
5	1	10022219					
6	4	20029011	VSKZ 8				
7	4	25044501	DIN912-M8x30-10.9				
8	1	20013037					
9	1	10005353					
10	4	20029003	VSK 8				
11	4	25038007	DIN933-M8x20				
12	1	10016736					
13	2	25001151					
14	0	20025528					
15	0	20025029					
16	0	20025378					
17	1	25017007					
18	1	10016737					
19	1	10016071					
20	1	20029001	VSK 10				
21	1	10007370					

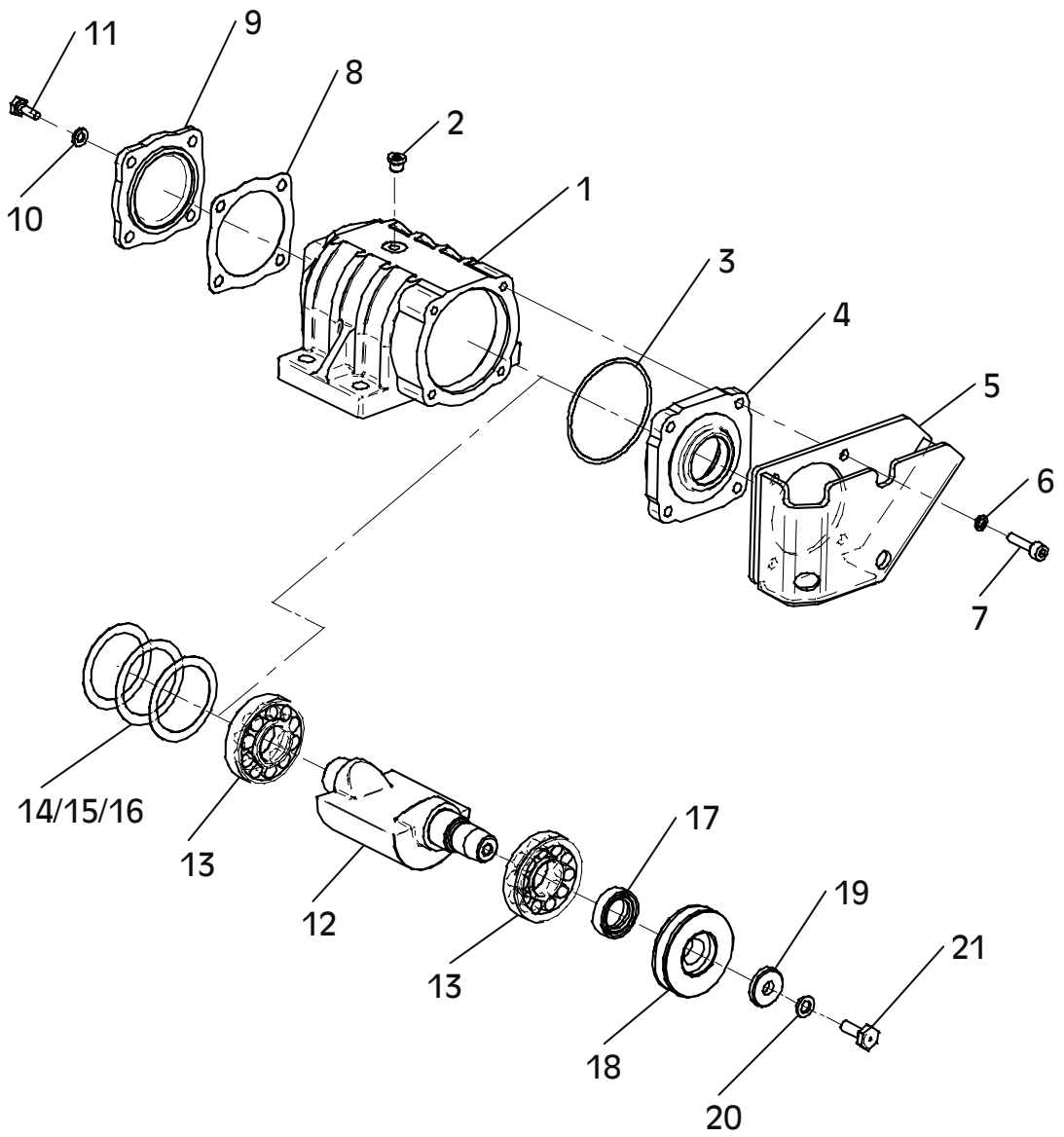

E 3049-0702

## E 3050-1005

Position Ref.No. Repère Posizione Posicion	Menge Quantity Quantité Quantita Cantidad	Teile-Nr. Part-No. No. Référence Nr. d'Ordine No. Referenzia	Hinweis Hints Indications Indicazione Indicaciones	Position Ref. No. Repère Posizione Posicion	Menge Quantity Quantité Quantita Cantidad	Teile-Nr. Part-No. No. Référence Nr. d'Ordine No. Referenzia	Hinweis Hints Indications Indicazione Indicaciones
1	1	10022221		31	1	10022222	
2	1	20001248		32	2	10009889	
3	2	10016341		33	2	25049013	DIN440-R11,5
4	4	25025185		34	2	20029001	VSK 10
5	4	25049026	DIN7349-8,4	35	2	25044037	DIN912-M10x55
6	4	20029024		36	2	20005012	
7	4	25031003	DIN934-M8	37	2	25048002	DIN125-A8,4
8	1	10005238		38	2	20029003	VSK 8
9	2	10016088		39	2	25031046	DIN1587-M8
10	1	20002101					
11	1	25002178					
12	1	20029021	SKB 8				
13	1	25043005	DIN933-5/16"				
14	1	10015989					
15	2	25048003	DIN125-A10,5				
16	2	20029012	VSKZ 10				
17	2	25044013	DIN912-M10x30				
18	1	10016093					
19	1	25049016	DIN440-R9				
20	1	20029003	VSK 8				
21	1	25038007	DIN933-M8x20				
22	1	20026465					
23	2	25025191	DIN80705-M20x1,5				
24	1	20025019					
25	1	20025690					
26	1	40002037					
27	1	10022223					
28	4	20029023	SKB 12				
30	4	25038020	DIN933-M12x30				



# Robin

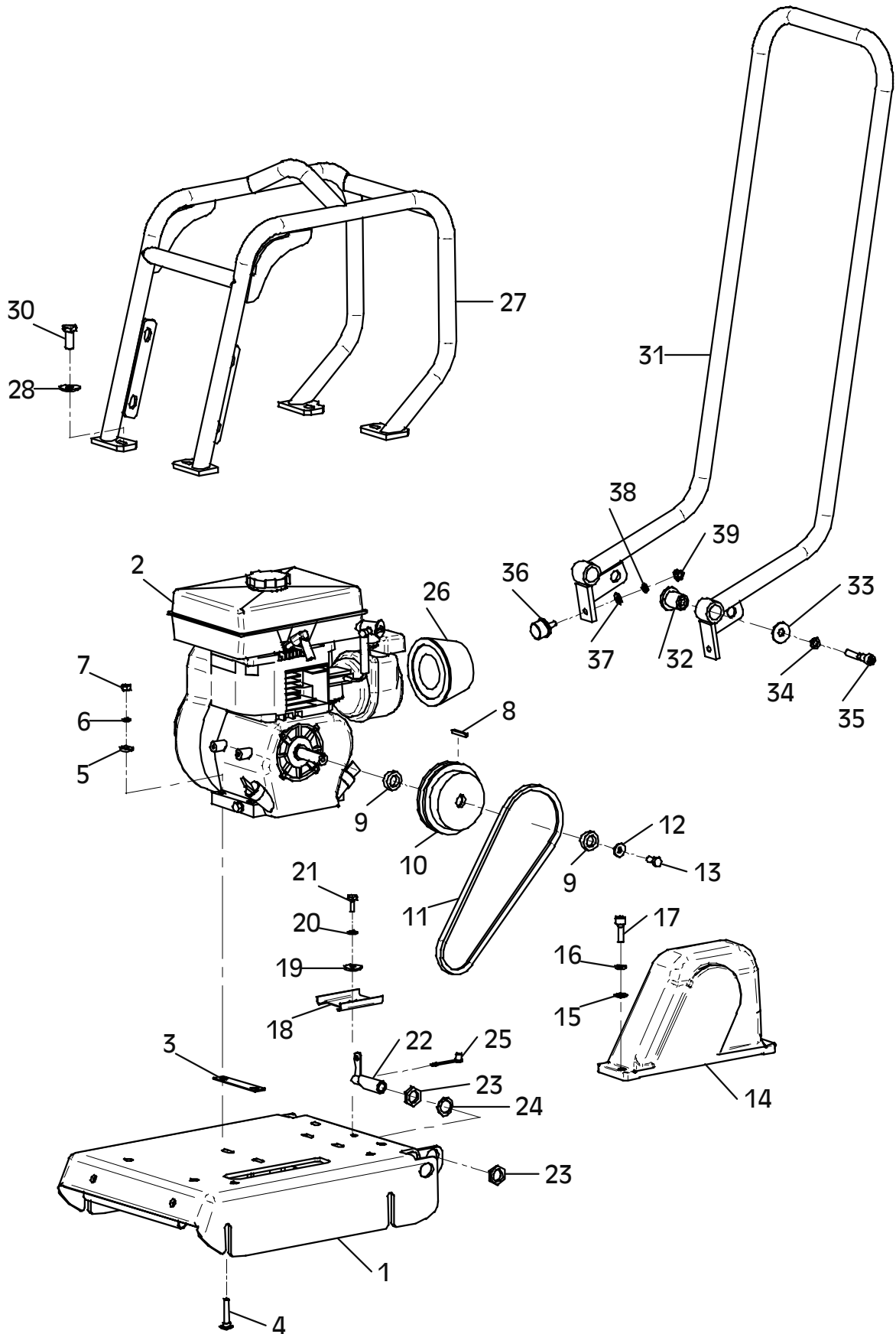

E 3050-1005

## E 3051-1005

Position Ref.No. Repère Posizione Posicion	Menge Quantity Quantité Quantita Cantidad	Teile-Nr. Part-No. No. Référence Nr. d'Ordine No. Referenzia	Hinweis Hints Indications Indicazione Indicaciones	Position Ref. No. Repère Posizione Posicion	Menge Quantity Quantité Quantita Cantidad	Teile-Nr. Part-No. No. Référence Nr. d'Ordine No. Referenzia	Hinweis Hints Indications Indicazione Indicaciones
1	1	10022221		32	2	10009889	
2	1	20001208		33	2	25049013	DIN440-R11,5
3	1	40140025		34	2	20029001	VSK 10
4	4	25033015	DIN603-M8x40	35	2	25044037	DIN912-M10x55
5	4	25049026	DIN7349-8,4	36	2	20005012	
6	4	20029024		37	2	25048002	DIN125-A8,4
7	4	25031003	DIN934-M8	38	2	20029003	VSK 8
8	1	10005238		39	2	25031046	DIN1587-M8
9	2	10016088					
10	1	20002101					
11	1	25002178					
12	1	20029021	SKB 8				
13	1	25043005	DIN933-5/16"				
14	1	10015989					
15	2	25048003	DIN125-A10,5				
16	2	20029012	VSKZ 10				
17	2	25044013	DIN912-M10x30				
18	1	10016093					
19	1	25049016	DIN440-R9				
20	1	20029003	VSK 8				
21	1	25038007	DIN933-M8x20				
22	1	20026465					
23	2	25025191	DIN80705-M20x1,5				
24	1	20025019					
25	1	20025690					
27	1	10022223					
28	4	20029023	SKB 12				
30	4	25038020	DIN933-M12x30				
31	1	10022222					

Honda

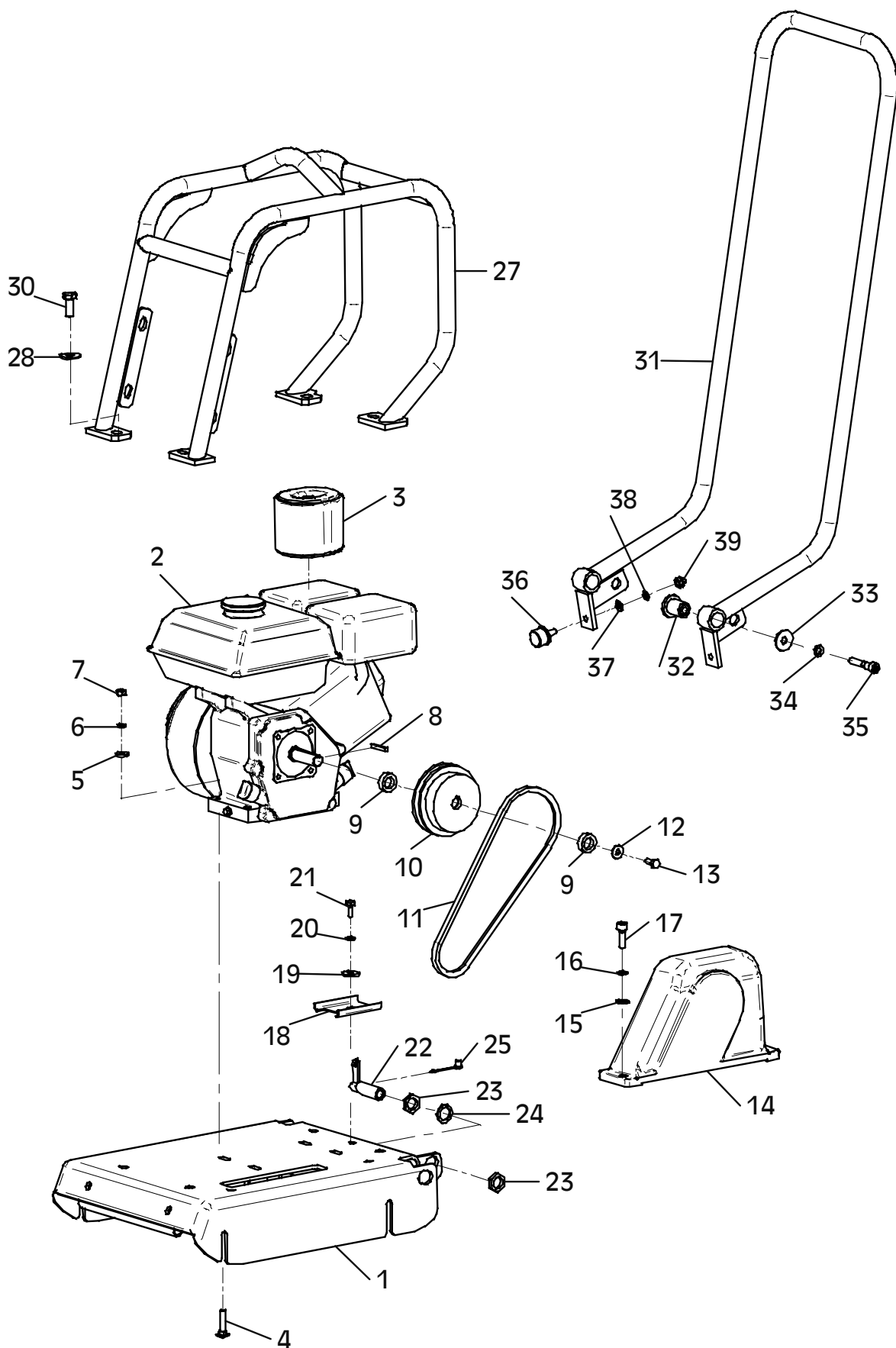

E 3051-1005

## E 3175-0704

Position Ref.No. Repère Posizione Posicion	Menge Quantity Quantité Quantita Cantidad	Teile-Nr. Part-No. No. Référence Nr. d'Ordine No. Referenzia	Hinweis Hints Indications Indicazione Indicaciones	Position Ref. No. Repère Posizione Posicion	Menge Quantity Quantité Quantita Cantidad	Teile-Nr. Part-No. No. Référence Nr. d'Ordine No. Referenzia	Hinweis Hints Indications Indicazione Indicaciones
1	1	20002101					
2	2	20002337					
3	2	20002223					

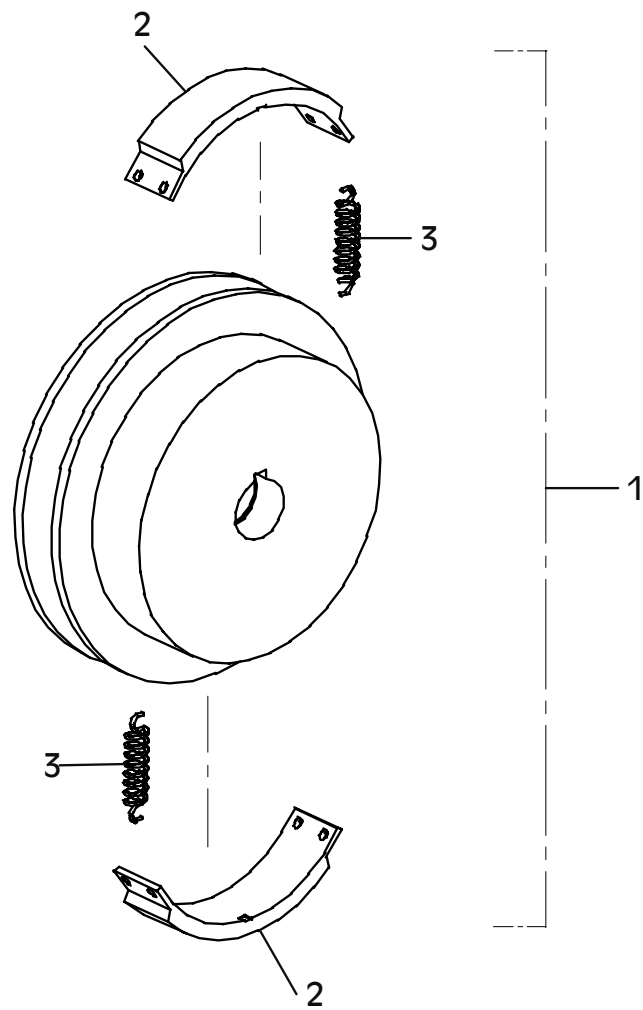

E 3175-0704

## E 3053-0702

Position Ref.No. Repère Posizione Posicion	Menge Quantity Quantité Quantita Cantidad	Teile-Nr. Part-No. No. Référence Nr. d'Ordine No. Referenzia	Hinweis Hints Indications Indicazione Indicaciones	Position Ref. No. Repère Posizione Posicion	Menge Quantity Quantité Quantita Cantidad	Teile-Nr. Part-No. No. Référence Nr. d'Ordine No. Referenzia	Hinweis Hints Indications Indicazione Indicaciones
1	1	20026461					
2	1	20025719					
3	4	25048003	DIN125-A10,5				
4	4	20029001	VSK 10				
5	4	25044041	DIN912-M10x20				
6	1	25048006	DIN125-A21				
7	1	20030018					
8	1	20025438					
9	1	20030010					
10	1	10016094					
11	1	10022224					
12	2	25030003	DIN908-M24x1,5				
13	2	20029022	SKB 10				
14	2	25038014	DIN933-M10x25				

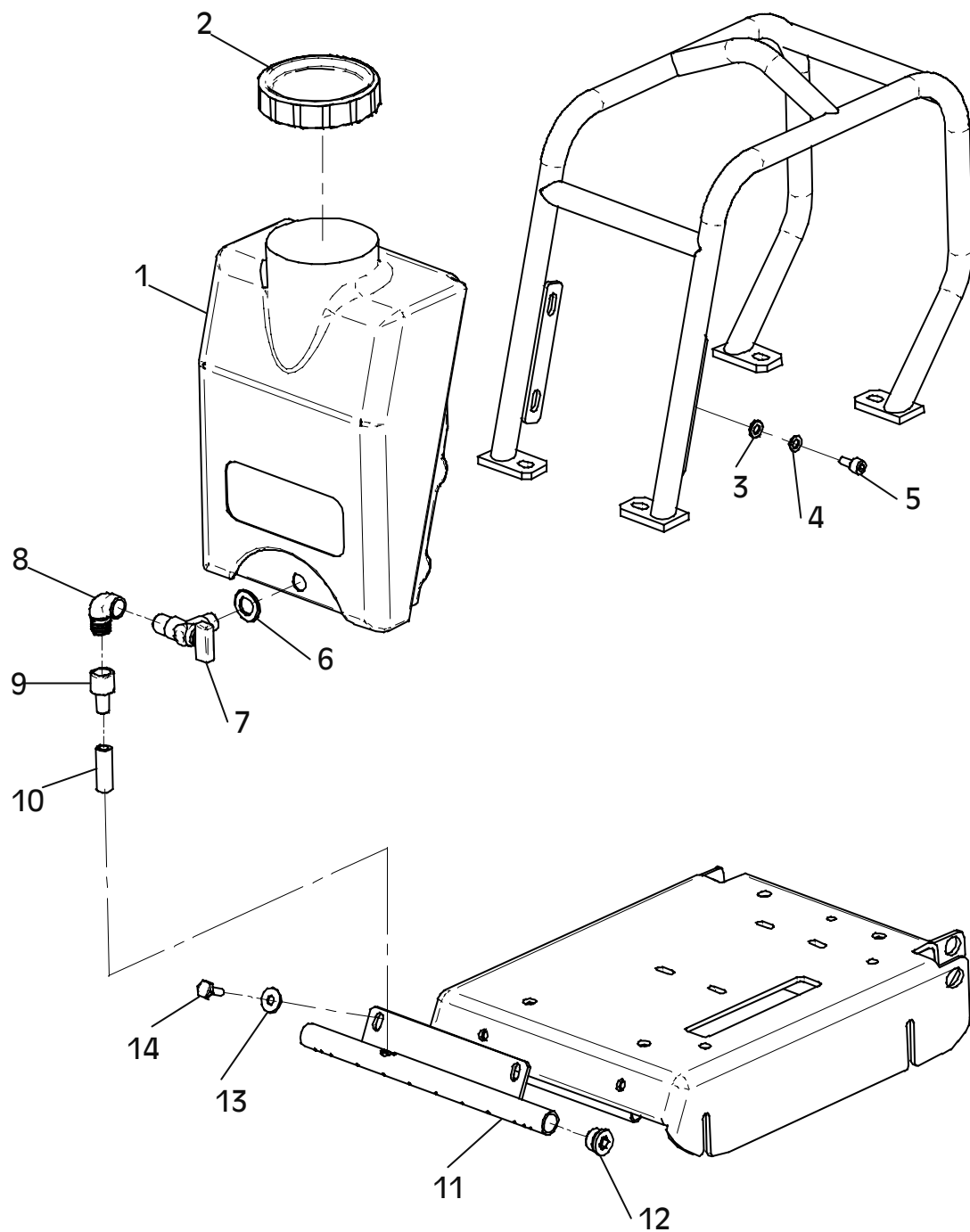

E 3053-0702

## E 3054-1005

Position Ref.No. Repère Posizione Posicion	Menge Quantity Quantité Quantita Cantidad	Teile-Nr. Part-No. No. Référence Nr. d'Ordine No. Referenzia	Hinweis Hints Indications Indicazione Indicaciones	Position Ref. No. Repère Posizione Posicion	Menge Quantity Quantité Quantita Cantidad	Teile-Nr. Part-No. No. Référence Nr. d'Ordine No. Referenzia	Hinweis Hints Indications Indicazione Indicaciones
1	1	10016096					
2	1	10007490					
3	2	25038071	DIN933-M10x45				
4	2	20029001	VSK 10				
5	2	25031004	DIN934-M10				
6	1	10022207					
7	2	20029001	VSK 10				
8	2	25038014	DIN933-M10x25				
9	1	20005010					
10	1	25048002	DIN125-A8,4				
11	1	25038006	DIN933-M8x16				
12	1	20026465					
13	2	25025191	DIN80705-M20x1,5				
14	1	20029009	VSK 20				
15	1	20025690					
16	1	10022208					
17	1	10016041					
18	2	20026466					
19	1	25036024					
20	2	20026272					
21	2	25048006	DIN125-A21				
22	2	20008088					
23	2	25048003	DIN125-A10,5				



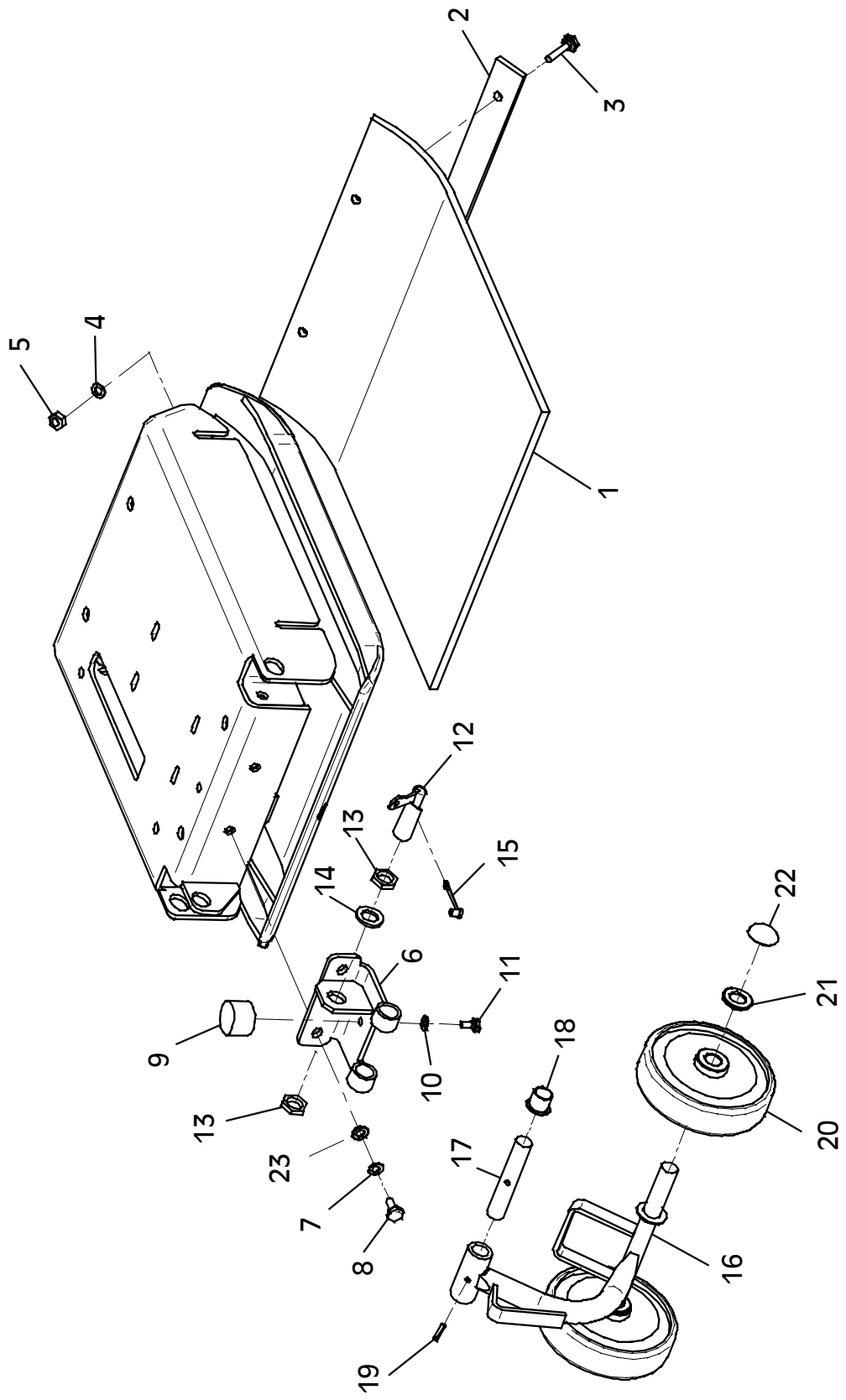

E 3054-1005



**Wenn Sie Fragen und Anregungen haben, oder sonstige Informationen benötigen,  
wenden Sie sich bitte an eine der unten genannten Adressen:**

**For questions and further information refer to one of the  
following addresses:**

<p><b>In Deutschland</b>  <b>In Germany</b></p>	<p>WEBER Maschinentechnik GmbH Postfach 2153 57329 Bad Laasphe – Rückershausen  Information / information: E-mail: info@webermt.de Ersatzteile / spare parts: E-mail: parts@webermt.de</p>	<p>Telefon / phone:  Telefax / fax:  Telefax / fax:</p>	<p>+49 (0) 2754 / 3980 Zentrale / switchboard  +49 (0) 2754 / 398101 Zentrale / switchboard  +49 (0) 2754 / 398102 Ersatzteile / spare parts direct dial</p>
<p><b>In Holland</b>  <b>In Netherlands</b></p>	<p>WEBER Maschinentechnik B.V. Graafschap Hornelaan 159 6001 AC Weert  E-mail: info@webermt.nl</p>	<p>Telefon / phone:  Telefax / fax:</p>	<p>+31 (0) 495 / 530215  +31 (0) 495 / 541839</p>
<p><b>In Frankreich</b>  <b>In France</b></p>	<p>WEBER Technologie S.A.R.L. 26, rue d' Arsonval 69680 Chassieu  E-mail: france@webermt.com</p>	<p>Telefon / phone:  Telefax / fax:</p>	<p>+33 (0) 472 / 791020  +33 (0) 472 / 791021</p>
<p><b>In Polen</b>  <b>In Poland</b></p>	<p>WEBER Maschinentechnik SP.ZO.O. ul. Grodziska 7 05-830 Stara Wies / Nadarzyn  E-mail: info@webermt.com.pl</p>	<p>Telefon / phone:  Telefax / fax:</p>	<p>+48 (0) 22 / 7397080 +48 (0) 22 / 7397081  +48 (0) 22 / 7397082</p>
<p><b>In USA, Kanada</b>  <b>In USA, Canada</b></p>	<p>WEBER Machine (USA), Inc. 40 Johnson Ave 112 Bangor, ME 04401 USA  E-mail: usa@webermt.com</p>	<p>Telefon / phone:  Telefax / fax:</p>	<p>+1 (0) 207 / 9474990  +1 (0) 207 / 9475452</p>
<p><b>In Südamerika</b>  <b>In South America</b></p>	<p>WEBER Maschinentechnik do Brasil Ltda. Rua Sete de Setembro, 275 93332-470 Novo Hamburgo, RS Brasil  E-mail: webermt@webermt.com.br</p>	<p>Telefon / phone:  Telefax / fax:</p>	<p>+55 (0) 51 / 5873044  +55 (0) 51 / 5872271</p>

<http://www.webermt.com>

