



ERSATZTEILLISTE

SPARE PARTS LIST

LISTE DES PIECES
DE RECHANGE

LISTINO RICAMBI

LISTA DE RECAMBIOS

WYKAZ CZESCI
ZAMIENNYCH



CF 3
010091-010096

03.2003

Weber Maschinenteknik GmbH
Postfach 2153, 57329 Bad Laasphe-Rückershausen
Telefon 02754 / 398-0
Telefax (02754) 398-101 (Zentrale) u. 398-102 (Ersatzteile)

EG - KONFORMITÄTSERKLÄRUNG

EC DECLARATION OF CONFORMITY/ DECLARATION DE CONFORMITE CE
DICHIAZIONE CE DI CONFORMITA / DECLARACION CE DE CONFORMIDAD
EG-VERKLARING VAN OVEREENSTEMMING / EF-OVERENSSTEMMELSESERKAERING
DECLARACAO CE DE CONFORMIDADE / EG-FÖRSÄKRAN OM ÖVERENSSTÄMMESE
DEKLARACJA ZGODNOŚCI

im Sinne der EG-Maschinenrichtlinie 98/37/EG
und der EG Richtlinie 2000/14/EG - Geräuschemissionen

- I **Art / Category / Catégorie / Categoria Tipo / Kategori /**
Soort / Categoria / kategori / Typ
- II **Hersteller (Typ) / Make (Type) / Marque (Type) / Marca (Tipo) /**
Marca (Codice) / Producent (Type) / Merk (Type) / Marca (Tipo) /
Tillverkare (Typ) / Producent
- III **Nennleistung / Nominal-performance / La puissance nominale / Prestazione nominale /**
Potencia nominal / Nominaal vermogen / Nominel ydelse / Potência nominal / Nominell
effect / Moc
- IV **gemessener Schalleistungspegel / measured sound power level / niveau de**
puissance acoustique mesure / livello di potenza sonora rilevato / nivel de potencia
acústica medido / gemeten geluidsvermogensniveau / målt lydeffektniveau / Nivel de
potência sonora midido / uppmätt ljudeffektnivå / Mierzony poziom dźwięku
- V **garantierter Schalleistungspegel / guaranteed sound power level / niveau de**
puissance acoustique garanti / livello di potenza sonora garantito / nivel de potencia
acústica garantizado / gewaarborgd geluidsvermogensniveau / garanteret lydeffektniveau /
Nivel sonoro garantido / garanterad ljudeffektnivå / Natężenie hałas
- VI **beteiligte Zertifizierungsstelle / notified body involved / de l'organisme notifié/**
dell'organismo notificato che l'ha effettuata / dirección del organismo notificado que haya
intervenido / betrokken aangemelde instantie / pagældende bemyndigede organ /
organismo notificado involucrado / berörda anmälda organets namn / Jednostka
certyfikująca
- VII **Konformitäts-Bewertungsverfahren / Conformity assessment procedure followed /**
la procédure appliquée pour l'évaluation de la conformité et / procedura di valutazione
della conformità / procedimiento de evaluación de la conformidad / gevolgd
overeenstemmingsbeoordelingsprocedure / den fulgte
overensstemmelsesvurderingsprocedure / procedimento de avaliacao de conformidade
/ Vilket förfarande för bedömning av överensstämmelse / Przebieg kontroli

Vibrationsplatte
CF 3



P = 3,5 kW

LWA = 107 dB (A)

LWA = 108 dB (A)

RWTÜV
Postfach 103161
D-45032 Essen

interne Fertigungskontrolle
nach Anhang VI
EG Richtlinie 2000/14/EG

ist in Übereinstimmung mit folgenden Richtlinien hergestellt worden /has been produced in accordance with following standards / est produit conforme aux dispositions des directives europeenes ci-apres / ha sido fabricado en conformidad con las siguientes normas / é stato fabbricato in conformità alle sequenti norme / er blevet fremstillet i overensstemmelse med følgende retningslinier / in overeenstemming met de volgende voorschriften gefabriceerd is / é fabricado conforme as seguintes normas / har tillverkats i överensstämmelse med följande riktlinjer / Zgodność z obowiązującymi przepisami

98/37/EG Maschinenrichtlinie des europäischen Parlamentes und des Rates vom 22. Juni 1998
2000/14/EG EG-Richtlinie Geräuschemissionen vom 8. Mai 2000
EN 500 Teil 1 Bewegliche Straßenbaumaschinen – Sicherheit
Gemeinsame Anforderungen
EN 500 Teil 4 Bewegliche Straßenbaumaschinen – Sicherheit
Besondere Anforderungen an Verdichtungsmaschinen

Bescheinigung bitte sorgfältig aufbewahren / File certificate carefully / Conserver certificat soigneusement / Conservar certificado cuidadosamente / Pregasi conservare accuratamente certificato / Beviset bedes opbevares omhyggeligt / Verklaring a.u.b. zorgvuldig bevar / Conservar o certificado com cuidado / Beviset skall om sorgfullt bevaras // Deklarację zgodności proszę zachować

Bad Laasphe – Rückershausen, den **02.01.2003**

W. Weber, Geschäftsführer



WEBER Maschinentechnik GmbH
Im Boden 5-8, 10 – D-57334 Bad Laasphe
Postfach 2153 – D-57329 Bad Laasphe
Telefon: 02754/398-0 – Fax 02754/398-101
E-mail: Verkauf@webermt.de
Internet: <http://www.webermt.de>



BITTE, NOTIEREN SIE SERIENNUMMER UND MOTORNUMMER IHRER MASCHINE:

PLEASE WRITE DOWN SERIALNUMBERS OF MACHINE AND ENGINE:

NOTEZ SVP LE NUMERO DE SERIE ET LE NUMERO DU MOTEUR DE VOTRE MACHINE:

SI PREGA DI ANNOTARE SEMPRE I NUMERI DI SERIE SIA DELLA VS. MACCHINA CHE DEL MOTORE:

MAQUINA: ROGAMOS ANOTEN EL NUMERO DE SERIE Y NUMERO DE MOTOR DE SU MAQUINA:

MASCHINE
MACHINE
MACCHINA
MAQUINA

#

MOTOR
ENGINE
MOTEUR
MOTORE

#

ZUR VERMEIDUNG VON FEHLLIEFERUNGEN UND VERZÖGERUNGEN SIND BEI DER BESTELLUNG VON ERSATZTEILEN FOLGENDE ANGABEN UNBEDINGT ERFORDERLICH:

- MASCHINENTYP
- SERIENNUMMER DER MASCHINE
- SERIENNUMMER DES MOTORS (BEI MOTORTEILEN)
- TEILENUMMER
- BESTELLMENGE

TO AVOID ERRORS IN DELIVERY PLEASE STATE THESE PARTICULARS WHEN ORDERING:

- TYPE OF MACHINE
- SERIAL NO. OF MACHINE
- SERIAL NO. OF ENGINE (ON ENGINE PARTS)
- PART-NO.
- QUANTITY REQUIRED

AFIN D'EVITER DES ERREURS DE COMMANDE ET DES RETARDS DE LIVRAISON IL EST NECESSAIRE D'INDIQUER LES CARACTERISTIQUES SUIVANTES:

- TYPE DE MACHINE
- LE NUMERO DE SERIE DE LA MACHINE
- LE NUMERO DE SERIE DU MOTEUR
- LE NUMERO D'IDENTITE DE LA PIECE
- LA QUANTITE SOUHAITEE

ONDE EVITARE DISGUIDI E RITARDI NELLE CONSEGNE DIE RICAMBI SI PREGA DI INDICARE SEMPRE:

- TIPO DELLA MACCHINA
- NUMERO DI SERIE DELLA MACCHINA
- NUMERO DI SERIE DEL MOTORE (SE SI RICHIEDONO PEZZI DEL MOTORE)
- NUMERO D'ORDINE DIE SINGOLI RICAMBI
- QUANTITA

A FI DE EVITAR ERRORES DE ENTREGA, ROGAMOS INDIQUEN LOS SIGUIENTES DATOS CUANDO PASE PEDIDOS DE RECAMBIO:

- MODELO DE MAQUINA
- NO. DE SERIE DE LA MAQUINA
- NO. DE SERIE DEL MOTOR (EN PIEZAS PARA MOTOR)
- REFERENCIA DEL RECAMBIO
- CANTIDAD PEDIDA

E 3078-0303

Position Ref.No. Repère Posizione Posicion	Menge Quantity Quantité Quantita Cantidad	Teile-Nr. Part-No. No. Référence Nr. d'Ordine No. Referenzia	Hinweis Hints Indications Indicazione Indicaciones	Position Ref. No. Repère Posizione Posicion	Menge Quantity Quantité Quantita Cantidad	Teile-Nr. Part-No. No. Référence Nr. d'Ordine No. Referenzia	Hinweis Hints Indications Indicazione Indicaciones
1	1	10016501	CF3				
1	1	10016494	CF3/40				
2	1	25030002	DIN908-M14x1,5				
3	1	10001435					
4	6	20029013	VSKZ 12				
5	6	25044071	DIN912-M12x75				
6	1	20013277					
7	4	20004004					
8	4	20029023	SKB 12				
9	4	20022004	Tensilock M12				
10	4	25049011	DIN7349-13x30x6				
11	4	20029004	VSK 12				
12	4	25031027	DIN1587-M12				

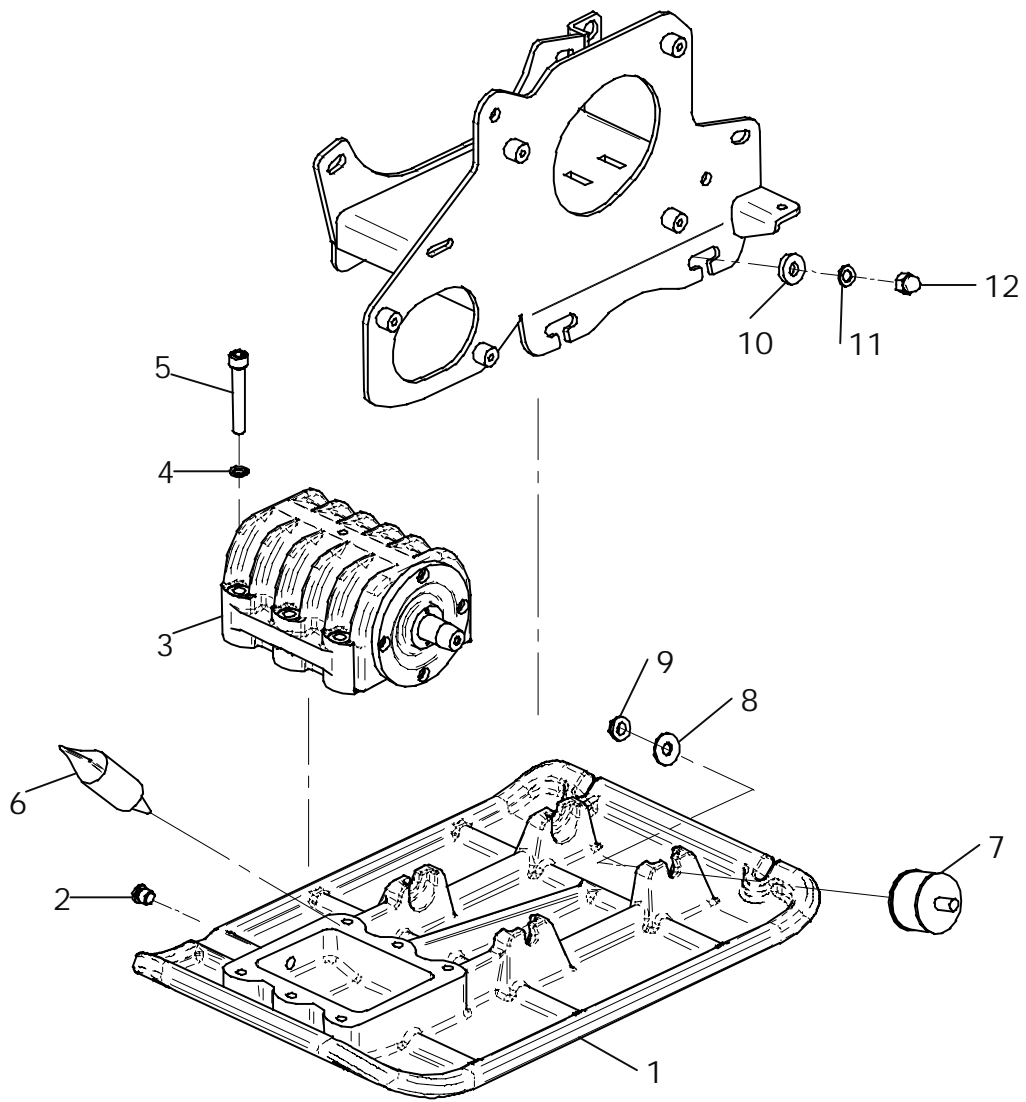

E 3079-0303

Position Ref.No. Repère Posizione Posicion	Menge Quantity Quantité Quantità Cantidad	Teile-Nr. Part-No. No. Référence Nr. d'Ordine No. Referenzia	Hinweis Hints Indications Indicazione Indicaciones	Position Ref. No. Repère Posizione Posicion	Menge Quantity Quantité Quantità Cantidad	Teile-Nr. Part-No. No. Référence Nr. d'Ordine No. Referenzia	Hinweis Hints Indications Indicazione Indicaciones
1	1	10016182					
2	1	25030001	DIN908-M10x1				
3	0	20025162					
4	0	20025163					
5	0	20025561					
6	1	20013008					
7	1	10005404					
8	4	20029003	VSK 8				
9	4	25038007	DIN933-M8x20				
10	1	10016496					
11	2	25001152					
12	1	10016895					
13	2	20029026					
14	2	25044040	DIN912-M12x60				
15	1	25017007					
16	1	10016500					
17	4	20029011	VSKZ 8				
18	4	25046023	DIN7984-M8x20				
19	1	20013294					
20	1	10016913					
21	1	10016912					
22	2	20029006	VSK 5				
23	2	25044056	DIN912-M5x30				
24	1	10016890					
25	1	10005346					
26	1	25005003					
27	1	10016302					

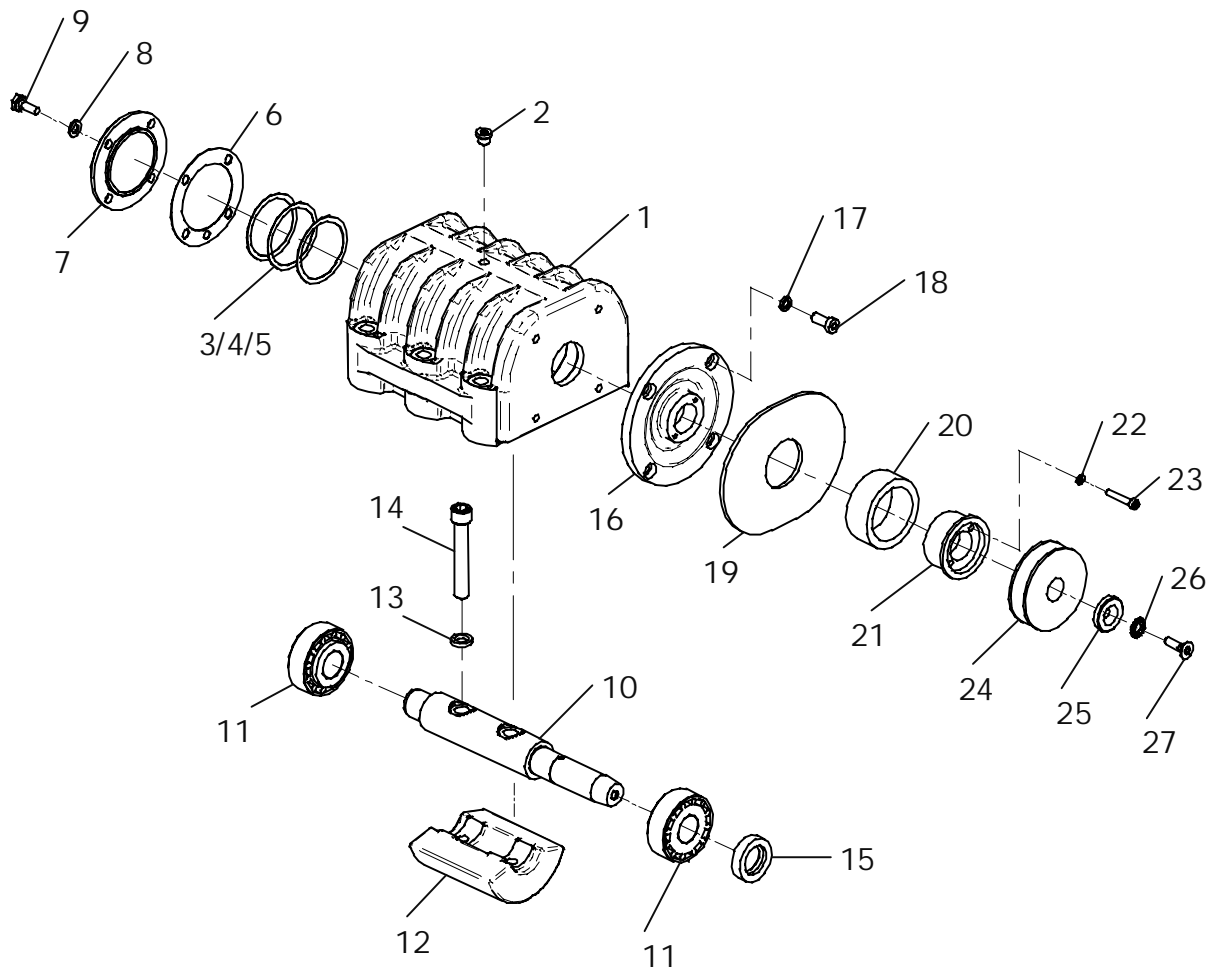

E 3079-0303

E 3080-0303

Position Ref.No. Repère Posizione Posicion	Menge Quantity Quantité Quantità Cantidad	Teile-Nr. Part-No. No. Référence Nr. d'Ordine No. Referenzia	Hinweis Hints Indications Indicazione Indicaciones	Position Ref. No. Repère Posizione Posicion	Menge Quantity Quantité Quantità Cantidad	Teile-Nr. Part-No. No. Référence Nr. d'Ordine No. Referenzia	Hinweis Hints Indications Indicazione Indicaciones
1	1	10022557		30	2	20029004	VSK 12
2	1	10016992		31	2	25031005	DIN934-M12
3	1	10016495		32	1	10022596	
4	5	25048002	DIN125-A8,4	33	4	25044026	DIN912-M12x35
5	5	20029003	VSK 8	34	8	25048004	DIN125-A13
6	5	25044055	DIN912-M8x50	35	4	20029004	VSK 12
7	2	20005010		36	4	25031005	DIN934-M12
8	2	20029003	VSK 8	37	1	20025480	
9	2	25038073	DIN933-M8x12	38	2	25005001	
10	1	20026465		39	2	25047016	DIN7991-M5x16
11	2	25025191		40	1	20006417	
12	1	20025019		41	2	10016341	
13	1	20001237					
14	4	25025185					
15	4	25049026	DIN7349-8,4				
16	4	20029024					
17	4	25031003	DIN934-M8				
18	1	25008006					
19	1	20025702					
20	1	20025704					
21	1	20002092					
22	1	25002095					
23	1	20029021	SKB 8				
24	1	25040028	DIN931-M8x45				
25	1	10022598					
26	2	10016261					
27	2	20025015					
28	2	25048012	DIN9021-13x40x3				
29	2	25040062	DIN931-M12x90				

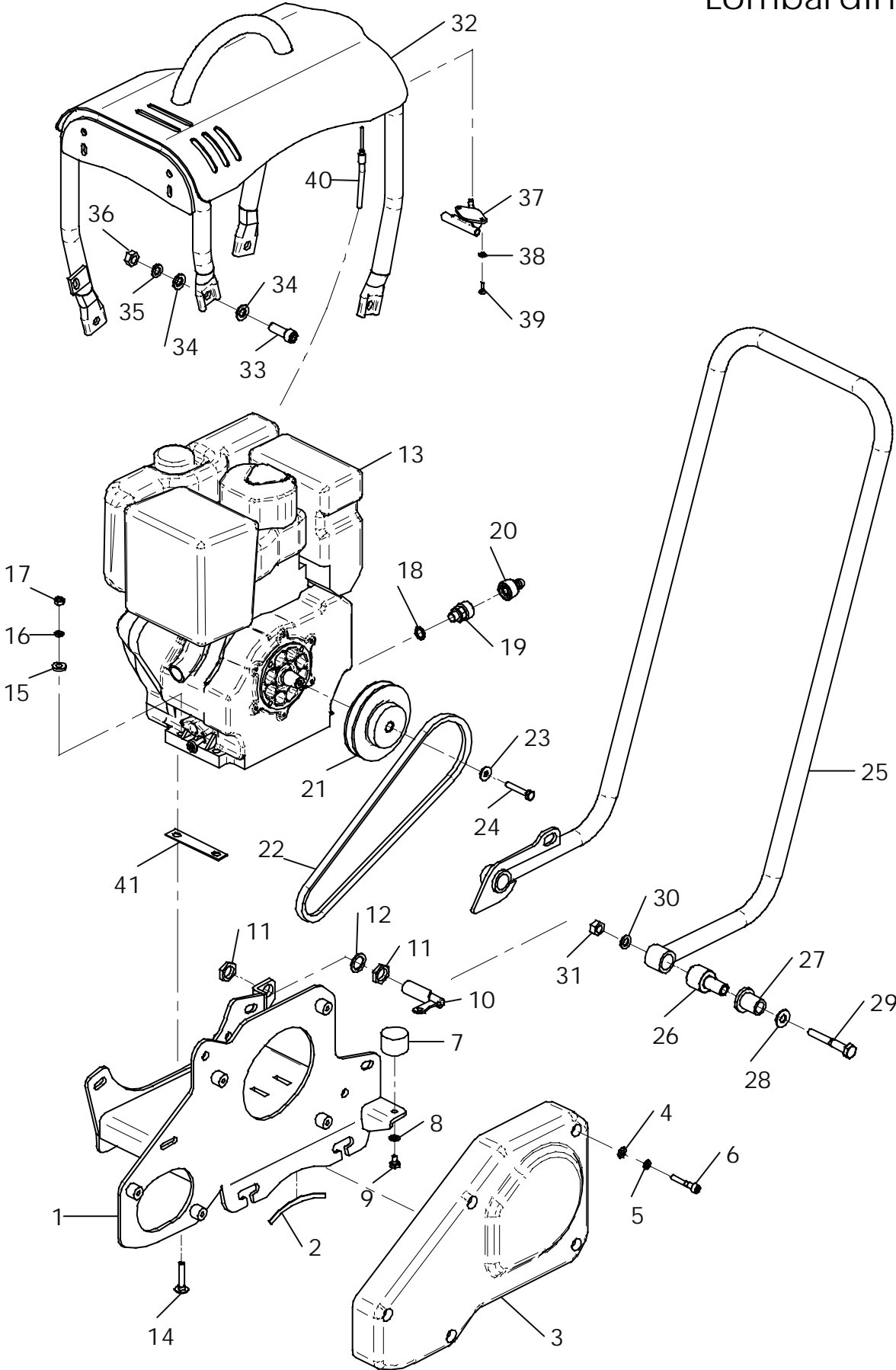

E 3081-0303

Position Ref.No. Repère Posizione Posicion	Menge Quantity Quantité Quantita Cantidad	Teile-Nr. Part-No. No. Référence Nr. d'Ordine No. Referenzia	Hinweis Hints Indications Indicazione Indicaciones	Position Ref. No. Repère Posizione Posicion	Menge Quantity Quantité Quantita Cantidad	Teile-Nr. Part-No. No. Référence Nr. d'Ordine No. Referenzia	Hinweis Hints Indications Indicazione Indicaciones
1	1	20002092					
2	2	20002254					
3	4	20002255					

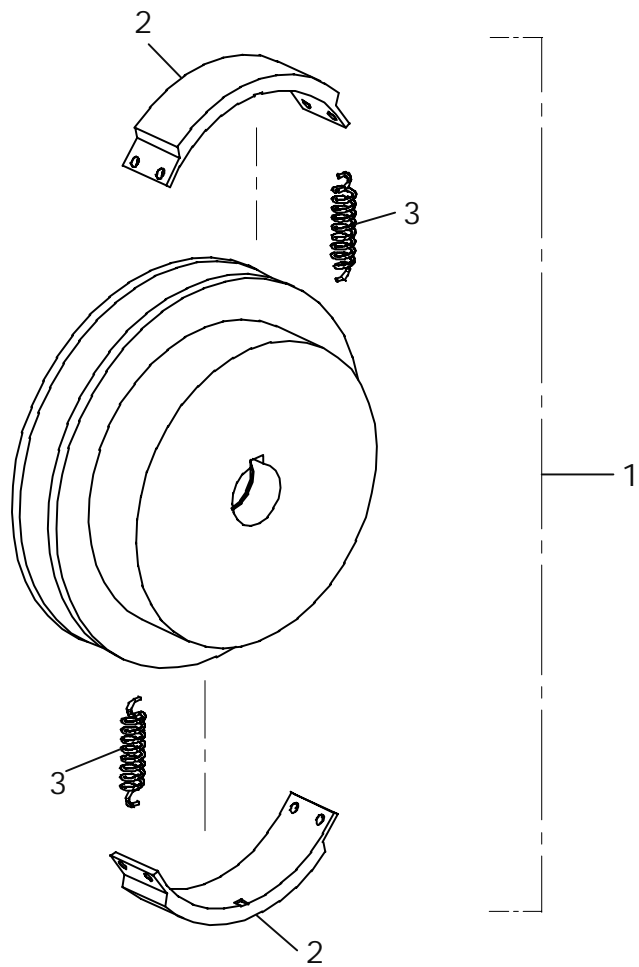

E 3081-0303

E 3082-0303

Position Ref.No. Repère Posizione Posicion	Menge Quantity Quantité Quantità Cantidad	Teile-Nr. Part-No. No. Référence Nr. d'Ordine No. Referenzia	Hinweis Hints Indications Indicazione Indicaciones	Position Ref. No. Repère Posizione Posicion	Menge Quantity Quantité Quantità Cantidad	Teile-Nr. Part-No. No. Référence Nr. d'Ordine No. Referenzia	Hinweis Hints Indications Indicazione Indicaciones
1	1	10022557		30	1	10022598	
2	1	10016992		31	2	10016261	
3	1	10016495		32	2	20025015	
4	5	25048002	DIN125-A8,4	33	2	25048012	DIN9021-13x40x3
5	5	20029003	VSK 8	34	2	25040062	DIN931-M12x90
6	5	25044055	DIN912-M8x50	35	2	20029004	VSK 12
7	2	20005010		36	2	25031005	DIN934-M12
8	2	20029003	VSK 8	37	1	10022597	
9	2	25038073	DIN933-M8x12	38	4	25044026	DIN912-M12x35
10	1	20026465		39	8	25048004	DIN125-A13
11	2	25025191		40	4	20029004	VSK 12
12	1	20025019		41	4	25031005	DIN934-M12
13	1	20001039					
14	2	10016903					
15	4	25033014	DIN603-M8x55				
16	4	25049026	DIN7349-8,4				
17	4	20029024					
18	4	25031003	DIN934-M8				
19	1	20002025					
20	1	10005238					
21	1	25002094					
22	1	10007359					
23	1	25049016	DIN440-R9				
24	1	20029003	VSK 8				
25	1	25038007	DIN933-M8x20				
26	1	10016093					
27	1	25049016	DIN440-R9				
28	1	20029003	VSK 8				
29	1	25038007	DIN933-M8x20				

Robin

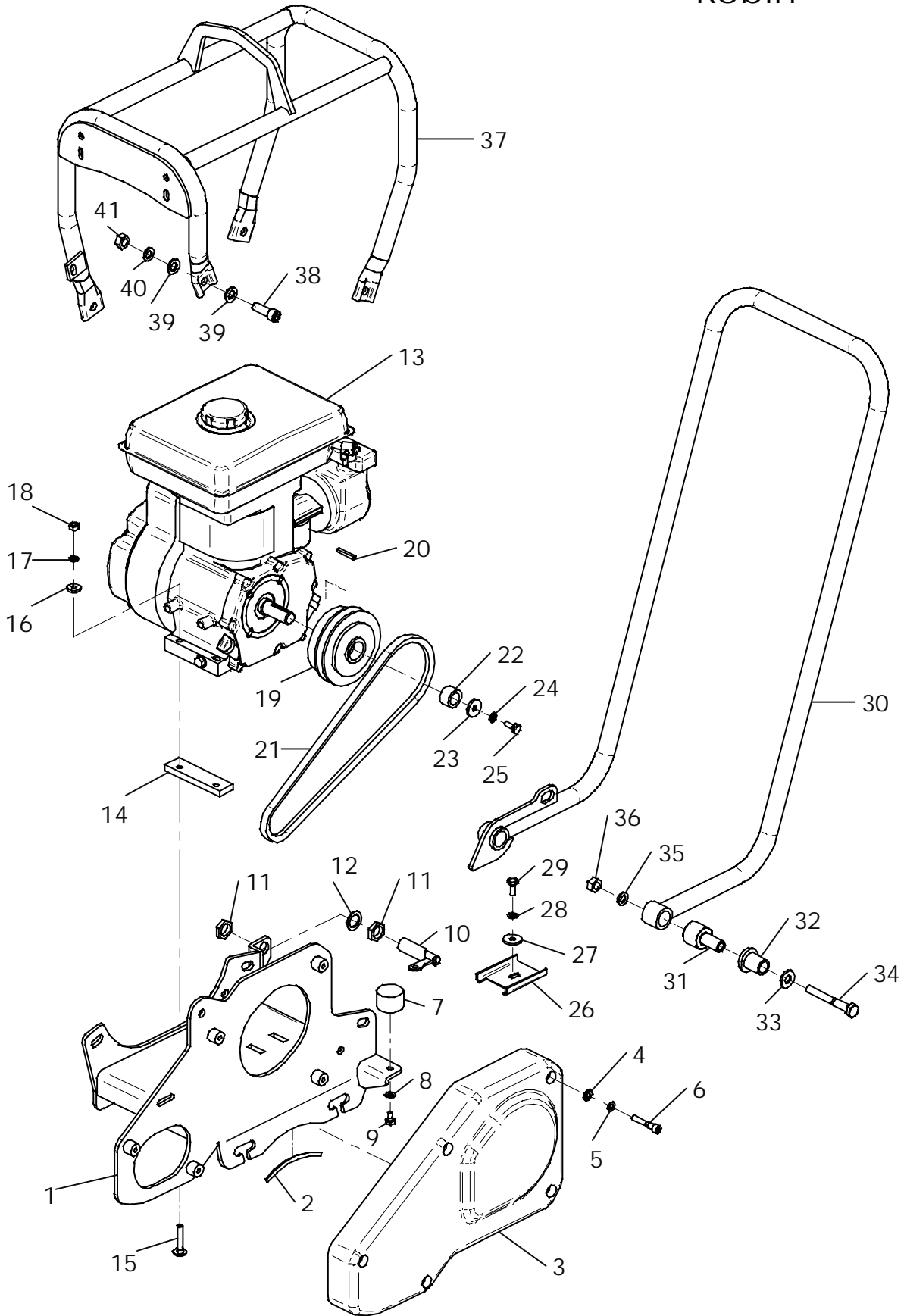

E 3082-0303

E 3083-0303

Position Ref.No. Repère Posizione Posicion	Menge Quantity Quantité Quantita Cantidad	Teile-Nr. Part-No. No. Référence Nr. d'Ordine No. Referenzia	Hinweis Hints Indications Indicazione Indicaciones	Position Ref. No. Repère Posizione Posicion	Menge Quantity Quantité Quantita Cantidad	Teile-Nr. Part-No. No. Référence Nr. d'Ordine No. Referenzia	Hinweis Hints Indications Indicazione Indicaciones
1	1	20002025					
2	2	20002231					
3	4	20002232					

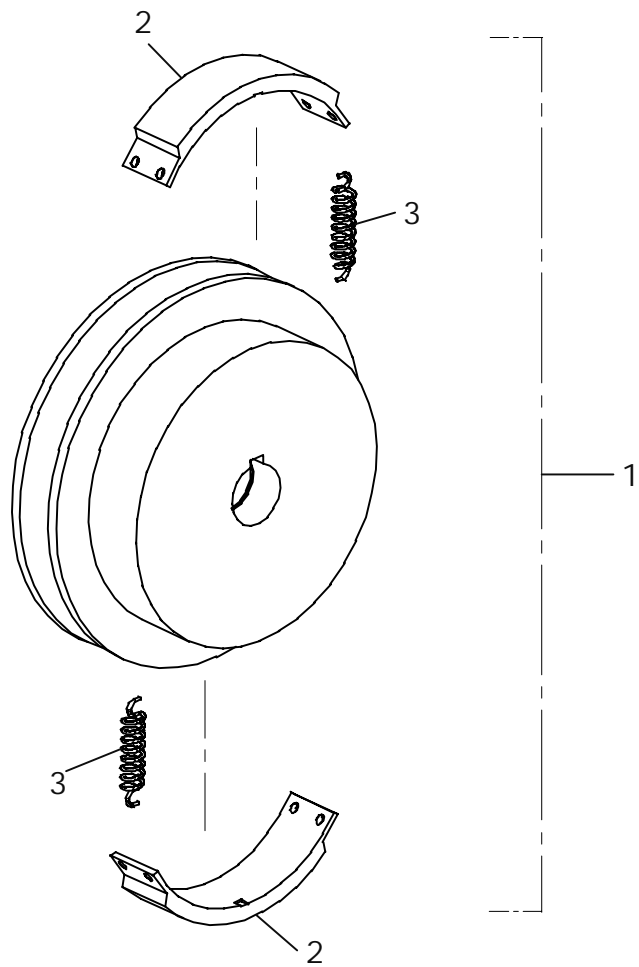

E 3083-0303

E 3084-0303

Position Ref.No. Repère Posizione Posicion	Menge Quantity Quantité Quantità Cantidad	Teile-Nr. Part-No. No. Référence Nr. d'Ordine No. Referenzia	Hinweis Hints Indications Indicazione Indicaciones	Position Ref. No. Repère Posizione Posicion	Menge Quantity Quantité Quantità Cantidad	Teile-Nr. Part-No. No. Référence Nr. d'Ordine No. Referenzia	Hinweis Hints Indications Indicazione Indicaciones
1	1	10022557		30	2	20025015	
2	1	10016992		31	2	25048012	DIN9021-13x40x3
3	1	10016495		32	2	25040062	DIN931-M12x90
4	5	25048002	DIN125-A8,4	33	2	20029004	VSK 12
5	5	20029003	VSK 8	34	2	25031005	DIN934-M12
6	5	25044055	DIN912-M8x50	35	1	10022597	
7	2	20005010		36	4	25044026	DIN912-M12x35
8	2	20029003	VSK 8	37	8	25048004	DIN125-A13
9	2	25038073	DIN933-M8x12	38	4	20029004	VSK 12
10	1	20026465		39	4	25031005	DIN934-M12
11	2	25025191					
12	1	20025019					
13	1	20001208					
14	4	25025185					
15	4	25049026	DIN7349-8,4				
16	4	20029024					
17	4	25031003	DIN934-M8				
18	1	20002047					
19	1	10005238					
20	1	25002094					
21	1	10015738					
22	1	20029021	SKB 8				
23	1	25043005	DIN933-5/16"				
24	1	10016093					
25	1	25049016	DIN440-R9				
26	1	20029003	VSK 8				
27	1	25038007	DIN933-M8x20				
28	1	10022598					
29	2	10016261					

Honda

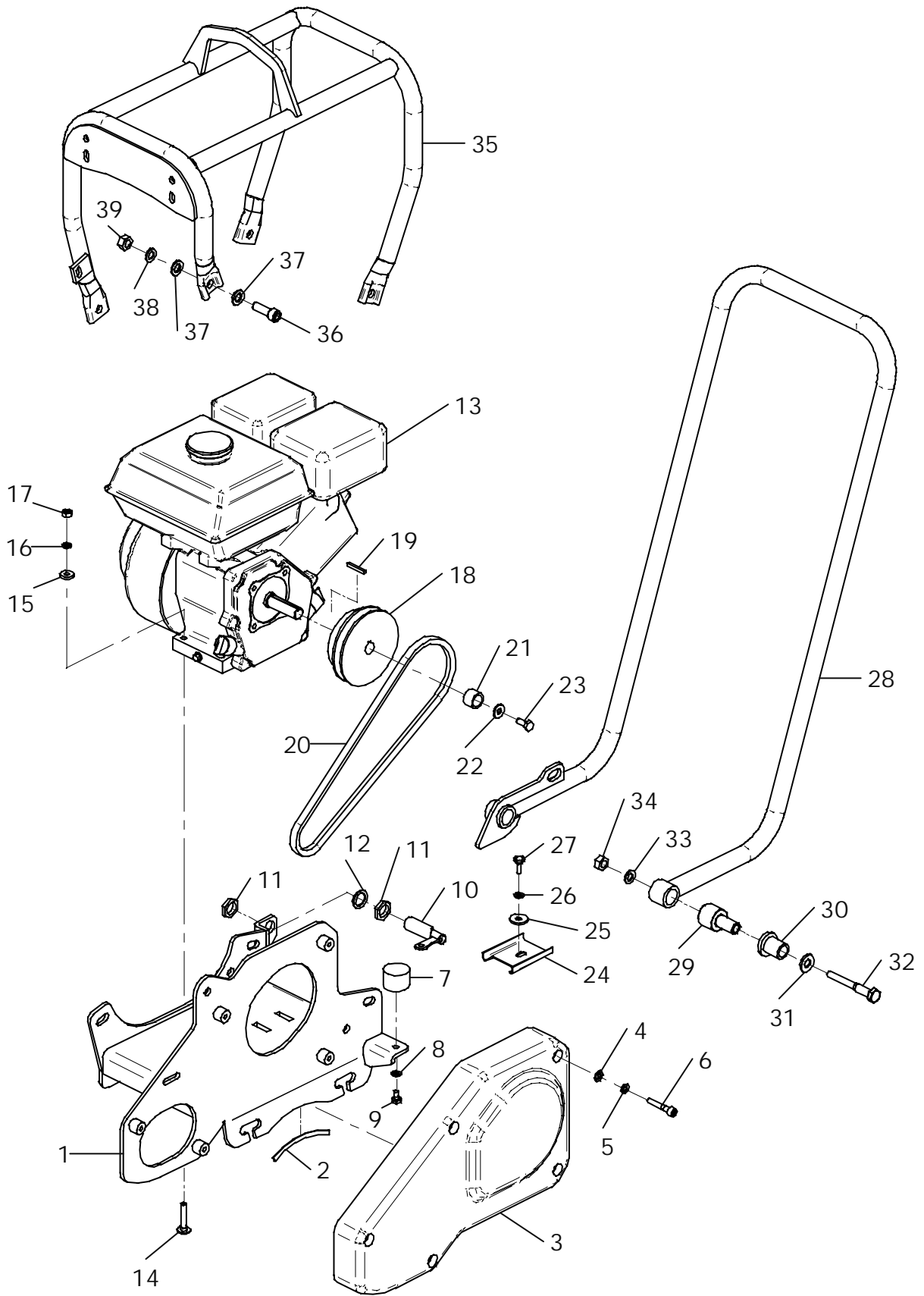

E 3084-0303

E 3062-1002

Position Ref.No. Repère Posizione Posicion	Menge Quantity Quantité Quantita Cantidad	Teile-Nr. Part-No. No. Référence Nr. d'Ordine No. Referenzia	Hinweis Hints Indications Indicazione Indicaciones	Position Ref. No. Repère Posizione Posicion	Menge Quantity Quantité Quantita Cantidad	Teile-Nr. Part-No. No. Référence Nr. d'Ordine No. Referenzia	Hinweis Hints Indications Indicazione Indicaciones
1	1	20002047					
2	2	20002254					
3	4	20002232					

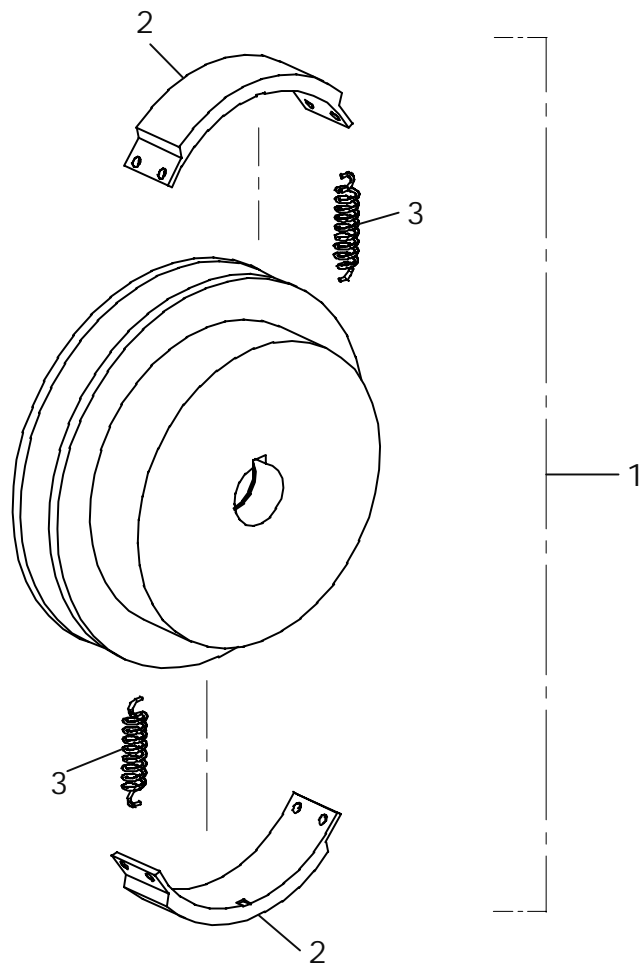

E 3086-0303

Position Ref.No. Repère Posizione Posicion	Menge Quantity Quantité Quantità Cantidad	Teile-Nr. Part-No. No. Référence Nr. d'Ordine No. Referenzia	Hinweis Hints Indications Indicazione Indicaciones	Position Ref. No. Repère Posizione Posicion	Menge Quantity Quantité Quantità Cantidad	Teile-Nr. Part-No. No. Référence Nr. d'Ordine No. Referenzia	Hinweis Hints Indications Indicazione Indicaciones
1	1	20026538					
2	1	20025719					
3	1	10016905					
4	1	25038007	DIN933-M8x20				
5	2	20029021	SKB 8				
6	1	25031003	DIN934-M8				
7	1	10022607					
8	1	20022002	Tensilock M8				
9	2	25044104	DIN912-M12x40				
10	4	25038006	DIN933-M8x16				
11	4	20029021	SKB 8				
12	2	25038006	DIN933-M8x16				
13	2	20029021	SKB 8				
14	2	10016981					
15	2	20029021	SKB 8				
16	2	25040027	DIN931-M8x35				
17	1	20030018					
18	1	20030016					
19	1	20030010					
20	1	20013292					
21	1	10016982	CF3				
21	1	10016904	CF3/40				
22	2	20025775					
23	2	20026480					

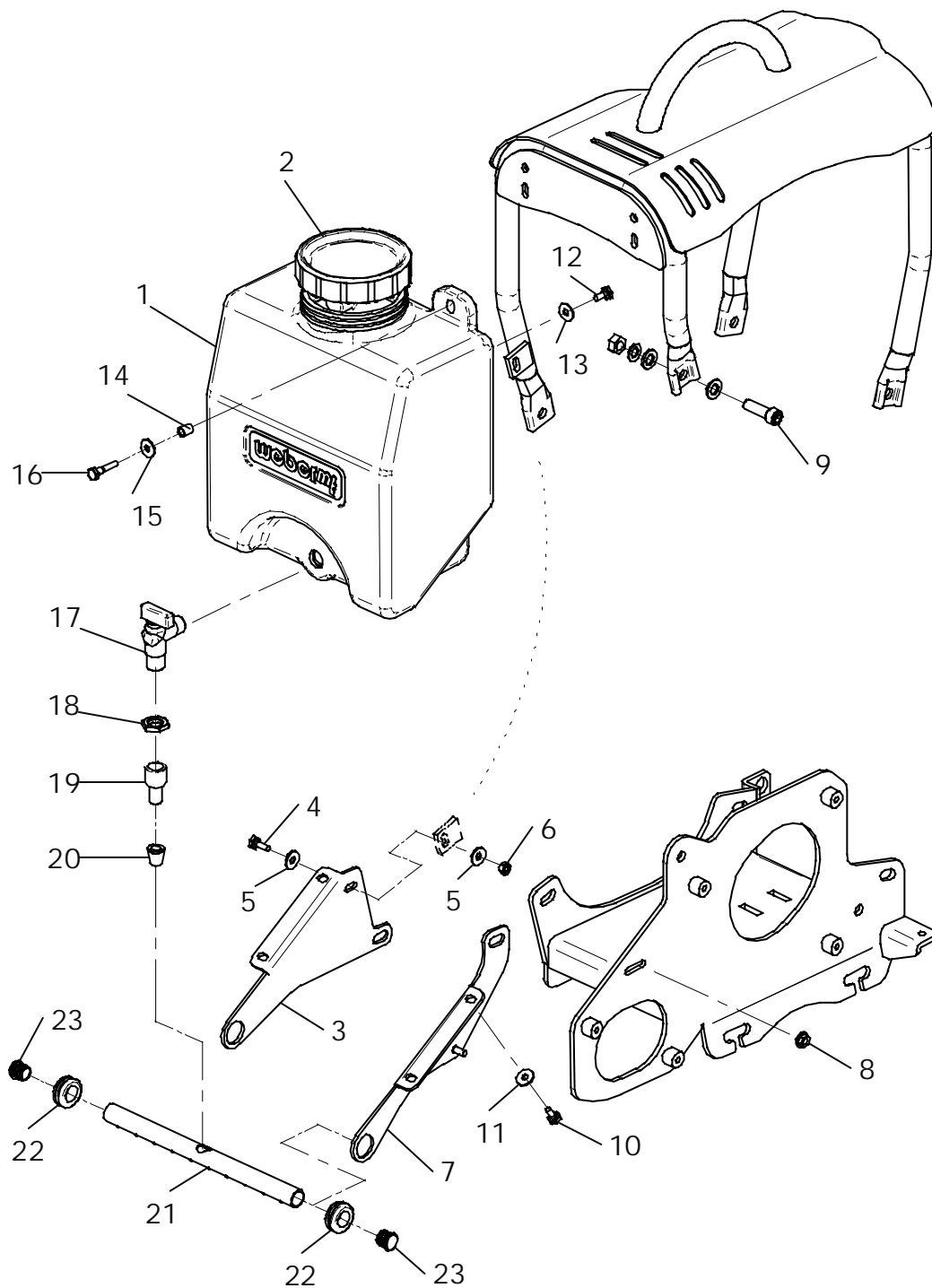

E 3086-0303

E 3087-0303

Position Ref.No. Repère Posizione Posicion	Menge Quantity Quantité Quantita Cantidad	Teile-Nr. Part-No. No. Référence Nr. d'Ordine No. Referenzia	Hinweis Hints Indications Indicazione Indicaciones	Position Ref. No. Repère Posizione Posicion	Menge Quantity Quantité Quantita Cantidad	Teile-Nr. Part-No. No. Référence Nr. d'Ordine No. Referenzia	Hinweis Hints Indications Indicazione Indicaciones
1	1	10022559					
2	2	20026272					
3	2	25048006	DIN125-A21				
4	2	20008088					
5	1	20005012					
6	1	20029003	VSK 8				
7	1	25031003	DIN934-M8				
8	1	10016284					
9	1	25036024					
10	2	20026466					
11	1	10022543					
12	2	20029001	VSK 10				
13	2	25038014	DIN933-M10x25				
14	1	20026481					
15	1	20025019					
16	2	25025191					

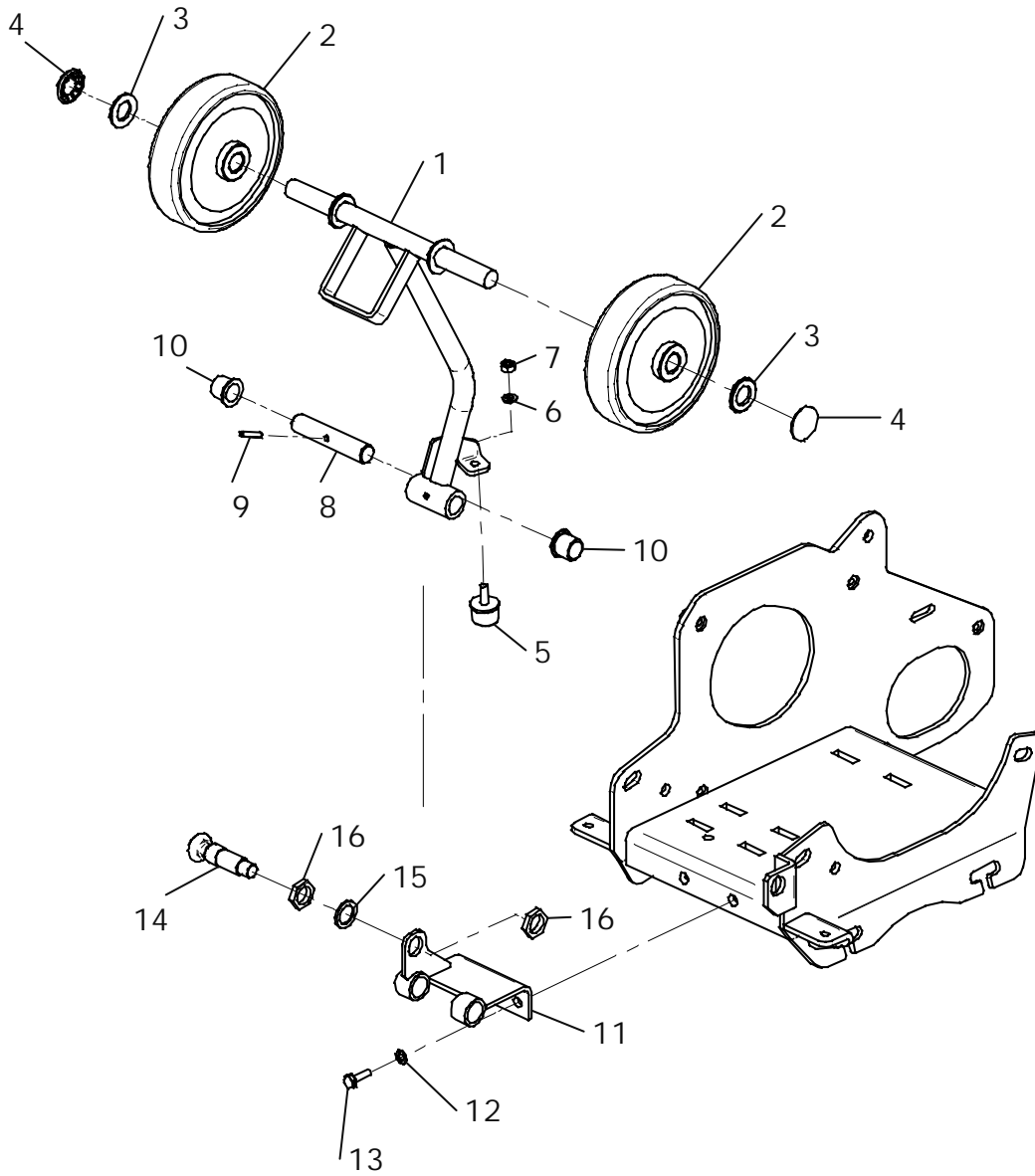

E 3087-0303

E 3088-0303

Position Ref.No. Repère Posizione Posicion	Menge Quantity Quantité Quantità Cantidad	Teile-Nr. Part-No. No. Référence Nr. d'Ordine No. Referenzia	Hinweis Hints Indications Indicazione Indicaciones	Position Ref. No. Repère Posizione Posicion	Menge Quantity Quantité Quantità Cantidad	Teile-Nr. Part-No. No. Référence Nr. d'Ordine No. Referenzia	Hinweis Hints Indications Indicazione Indicaciones
1	1	10016721	CF3				
1	1	10016722	CF3/40				
2	1	10022600	CF3				
2	1	10022601	CF3/40				
3	2	25049013	DIN440-R11,5				
4	2	25031004	DIN934-M10				
5	2	10016430					
6	2	25048003	DIN125-A10,5				
7	2	25047044	DIN7991-M10x25				

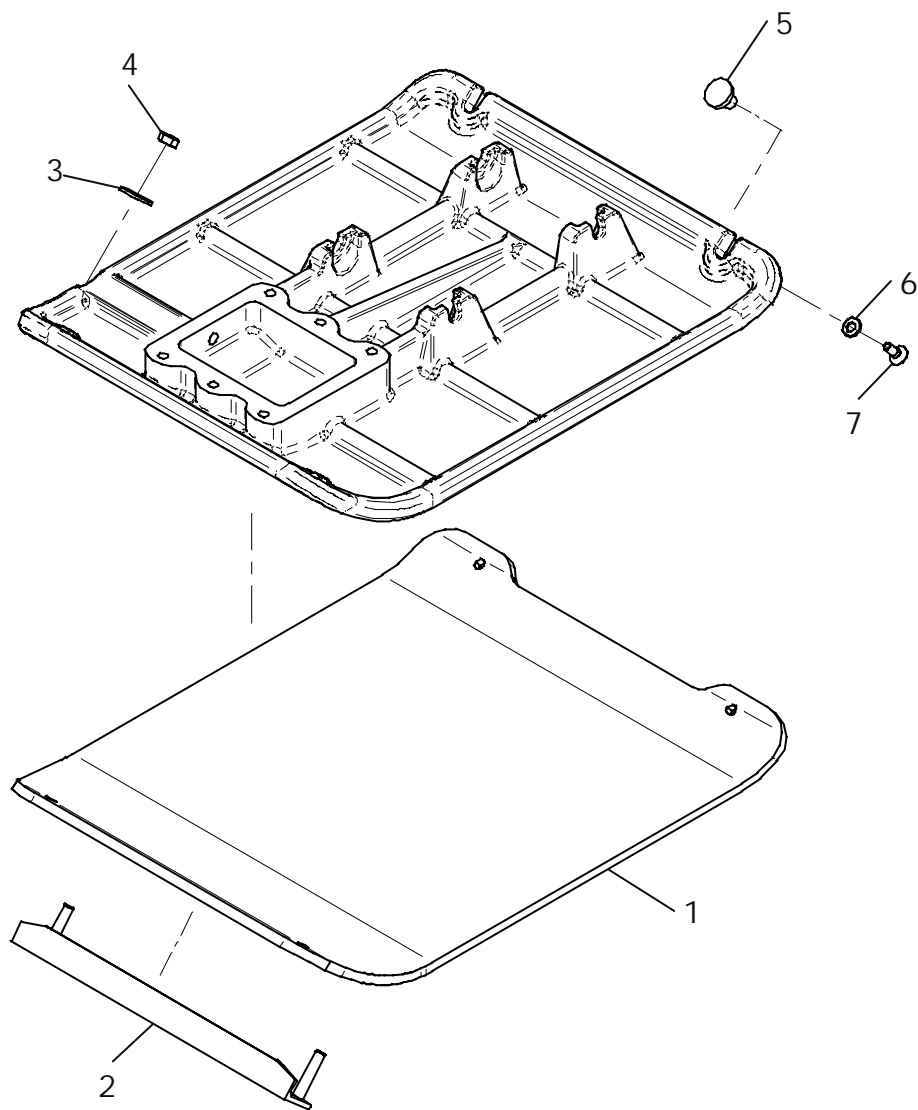

E 3088-0303

**Wenn Sie Fragen und Anregungen haben, oder sonstige Informationen benötigen,
wenden Sie sich bitte an eine der unten genannten Adressen:**

**For questions and further information refer to one of the
following addresses:**

<p>In Deutschland In Germany</p>	<p>WEBER Maschinentechnik GmbH Postfach 2153 57329 Bad Laasphe – Rückershausen Information / information: E-mail: info@webermt.de Ersatzteile / spare parts: E-mail: parts@webermt.de</p>	<p>Telefon / phone: Telefax / fax: Telefax / fax:</p>	<p>+49 (0) 2754 / 3980 Zentrale / switchboard +49 (0) 2754 / 398101 Zentrale / switchboard +49 (0) 2754 / 398102 Ersatzteile / spare parts direct dial</p>
<p>In Holland In Netherlands</p>	<p>WEBER Maschinentechnik B.V. Graafschap Hornelaan 159 6001 AC Weert E-mail: info@webermt.nl</p>	<p>Telefon / phone: Telefax / fax:</p>	<p>+31 (0) 495 / 530215 +31 (0) 495 / 541839</p>
<p>In Frankreich In France</p>	<p>WEBER Technologie S.A.R.L. 26, rue d' Arsonval 69680 Chassieu E-mail: france@webermt.com</p>	<p>Telefon / phone: Telefax / fax:</p>	<p>+33 (0) 472 / 791020 +33 (0) 472 / 791021</p>
<p>In Polen In Poland</p>	<p>WEBER Maschinentechnik SP.ZO.O. ul. Grodziska 7 05-830 Stara Wies / Nadarzyn E-mail: info@webermt.com.pl</p>	<p>Telefon / phone: Telefax / fax:</p>	<p>+48 (0) 22 / 7397080 +48 (0) 22 / 7397081 +48 (0) 22 / 7397082</p>
<p>In USA, Kanada In USA, Canada</p>	<p>WEBER Machine (USA), Inc. 40 Johnson Ave 112 Bangor, ME 04401 USA E-mail: usa@webermt.com</p>	<p>Telefon / phone: Telefax / fax:</p>	<p>+1 (0) 207 / 9474990 +1 (0) 207 / 9475452</p>
<p>In Südamerika In South America</p>	<p>WEBER Maschinentechnik do Brasil Ltda. Rua Sete de Setembro, 275 93332-470 Novo Hamburgo, RS Brasil E-mail: webermt@webermt.com.br</p>	<p>Telefon / phone: Telefax / fax:</p>	<p>+55 (0) 51 / 5873044 +55 (0) 51 / 5872271</p>

<http://www.webermt.com>

