



ERSATZTEILLISTE

SPARE PARTS LIST

**LISTE DES PIECES
DE RECHANGE**

LISTINO RICAMBI

LISTA DE RECAMBIOS

**WYKAZ CZESCI
ZAMIENNYCH**



CF 4

010071-010076



Weber Maschinenteknik GmbH
Postfach 2153, 57329 Bad Laasphe-Rückershausen
Telefon 02754 / 398-0
Telefax (02754) 398-101 (Zentrale) u. 398-102 (Ersatzteile)

EG - KONFORMITÄTSERKLÄRUNG

EC DECLARATION OF CONFORMITY / DECLARATION DE CONFORMITE CE
DICHIARAZIONE CE DI CONFORMITA / DECLARACION CE DE CONFORMIDAD
EG-VERKLARING VAN OVEREENSTEMMING / EF-OVERENSSTEMMELSESERKAERING
DECLARACAO CE DE CONFORMIDADE / EG-FÖRSÄKRAN OM ÖVERENSSTÄMMELSE
DEKLARACJA ZGODNOŚCI

im Sinne der EG-Maschinenrichtlinie 98/37/EG
und der EG Richtlinie 2000/14/EG - Geräuschemissionen

- I **Art / Category / Catégorie / Categoria Tipo / Kategori /**
Soort / Categoria / kategori / Typ
- II **Hersteller (Typ) / Make (Type) / Marque (Type) / Marca (Tipo) /**
Marca (Codice) / Producent (Type) / Merk (Type) / Marca (Tipo) /
Tillverkare (Typ) / Producent
- III **Nennleistung / Nominal-performance / La puissance nominale / Prestazione nominale /**
Potencia nominal / Nominaal vermogen / Nominel ydelse / Potência nominal / Nominell
effect / Moc
- IV **gemessener Schalleistungspegel / measured sound power level / niveau de**
puissance acoustique mesure / livello di potenza sonora rilevato / nivel de potencia
acústica medido / gemeten geluidsvermogensniveau / målt lydeffektniveau / Nivel de
potência sonora midido / uppmätt ljudeffektnivå / Mierzony poziom dźwięku
- V **garantierter Schalleistungspegel / guaranteed sound power level / niveau de**
puissance acoustique garanti / livello di potenza sonora garantito / nivel de potencia
acustica garantizado / gewaarborgd geluidsvermogensniveau / garanteret lydeffektniveau /
Nivel sonoro garantido / garanterad ljudeffektnivå / Natężenie hałas
- VI **beteiligte Zertifizierungsstelle / notified body involved / de l'organisme notifié /**
dell'organismo notificato che l'ha effettuata / dirección del organismo notificado que haya
intervenido / betrokken aangemelde instantie / pagældende bemyndigede organ /
organismo notificado involucrado / berörda anmälda organets namn / Jednostka
certyfikująca
- VII **Konformitäts-Bewertungsverfahren / Conformity assessment procedure followed /**
la procédure appliquée pour l'évaluation de la conformité et / procedura di valutazione
della conformità / procedimiento de evaluación de la conformidad / gevolgde
overeenstemmingsbeoordelingsprocedure / den fulgte
overensstemmelssesvurderingsprocedure / procedimento de avaliacao de conformidade
/ Vilket förfarande för bedömning av överensstämmelse / Przebieg kontroli

Vibrationsplatte
CF 4



P = 3,4 kW

LWA = 107 dB (A)

LWA = 108 dB (A)

RWTÜV
Postfach 103161
D-45032 Essen

interne Fertigungskontrolle
nach Anhang VI
EG Richtlinie 2000/14/EG

ist in Übereinstimmung mit folgenden Richtlinien hergestellt worden / has been produced in accordance with following standards / est produit conforme aux dispositions des directives europeenes ci-apres / ha sido fabricado en conformidad con las siguientes normas / é stato fabbricato in conformità alle sequenti norme / er blevet fremstillet i overensstemmelse med følgende retningslinier / in overeenstemming met de volgende voorschriften gefabriceerd is / é fabricado conforme as seguintes normas / har tillverkats i överensstämmelse med följande riktlinjer / Zgodność z obowiązującymi przepisami

98/37/EG Maschinenrichtlinie des europäischen Parlamentes und des Rates vom 22. Juni 1998
2000/14/EG EG-Richtlinie Geräuschemissionen vom 8. Mai 2000
EN 500 Teil 1 Bewegliche Straßenbaumaschinen – Sicherheit
Gemeinsame Anforderungen
EN 500 Teil 4 Bewegliche Straßenbaumaschinen – Sicherheit
Besondere Anforderungen an Verdichtungsmaschinen

Bescheinigung bitte sorgfältig aufbewahren / File certificate carefully / Conserver certificat soigneusement / Conservar certificado cuidadosamente / Pregasi conservare accuratamente certificato / Beviset bedes opbevares omhyggeligt / Verklaring a.u.b. zorgvuldig bevar / Conservar o certificado com cuidado / Beviset skall om sorgfullt bevaras // Deklarację zgodności proszę zachować

Bad Laasphe – Rückershausen, den **02.01.2004**

W. Weber, Geschäftsführer

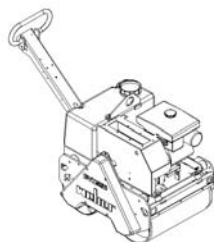

WEBER Maschinentechnik GmbH

Im Boden 5-8, 10 – D-57334 Bad Laasphe
Postfach 2153 – D-57329 Bad Laasphe
Telefon: 02754/398-0 – Fax 02754/398-101
E-mail: Verkauf@webermt.de
Internet: <http://www.webermt.de>



BITTE, NOTIEREN SIE SERIENNUMMER UND MOTORNUMMER IHRER MASCHINE:

PLEASE WRITE DOWN SERIALNUMBERS OF MACHINE AND ENGINE:

NOTEZ SVP LE NUMERO DE SERIE ET LE NUMERO DU MOTEUR DE VOTRE MACHINE:

SI PREGA DI ANNOTARE SEMPRE I NUMERI DI SERIE SIA DELLA VS. MACCHINA CHE DEL MOTORE:

MAQUINA: ROGAMOS ANOTEN EL NUMERO DE SERIE Y NUMERO DE MOTOR DE SU MAQUINA:

PROSIMY ZANOTOWAĆ NUMER MASZYNY I SILNIKA

MASCHINE
MACHINE
MACCHINA
MAQUINA
MASZYNA

MOTOR
ENGINE
MOTEUR
MOTORE
SILNIK

ZUR VERMEIDUNG VON FEHLLIEFERUNGEN UND VERZÖGERUNGEN SIND BEI DER BESTELLUNG VON ERSATZTEILEN FOLGENDE ANGABEN UNBEDINGT ERFORDERLICH:

- MASCHINENTYP
- SERIENNUMMER DER MASCHINE
- SERIENNUMMER DES MOTORS (BEI MOTORTEILEN)
- TEILENUMMER
- BESTELLMENGE

TO AVOID ERRORS IN DELIVERY PLEASE STATE THESE PARTICULARS WHEN ORDERING:

- TYPE OF MACHINE
- SERIAL NO. OF MACHINE
- SERIAL NO. OF ENGINE (ON ENGINE PARTS)
- PART-NO.
- QUANTITY REQUIRED

AFIN D'EVITER DES ERREURS DE COMMANDE ET DES RETARDS DE LIVRAISON IL EST NECESSAIRE D'INDIQUER LES CARACTERISTIQUES SUIVANTES:

- TYPE DE MACHINE
- LE NUMERO DE SERIE DE LA MACHINE
- LE NUMERO DE SERIE DU MOTEUR
- LE NUMERO D'IDENTITE DE LA PIECE
- LA QUANTITE SOUHAITEE

ONDE EVITARE DISGUIDI E RITARDI NELLE CONSEGNE DIE RICAMBI SI PREGA DI INDICARE SEMPRE:

- TIPO DELLA MACCHINA
- NUMERO DI SERIE DELLA MACCHINA
- NUMERO DI SERIE DEL MOTORE (SE SI RICHIEDONO PEZZI DEL MOTORE)
- NUMERO D'ORDINE DIE SINGOLI RICAMBI
- QUANTITA

A FI DE EVITAR ERRORES DE ENTREGA, ROGAMOS INDIQUEN LOS SIGUIENTES DATOS CUANDO PASE PEDIDOS DE RECAMBIO:

- MODELO DE MAQUINA
- NO. DE SERIE DE LA MAQUINA
- NO. DE SERIE DEL MOTOR (EN PIEZAS PARA MOTOR)
- REFERENCIA DEL RECAMBIO
- CANTIDAD PEDIDA

PROSIMY O PODANIE NASTĘPUJĄCYCH DANYCH PRZY SKŁADANIU ZAMÓWIENIA.

- TYP MASZYNY
- NUMER SERYJNY MASZYNY
- NUMER SERYJNY SILNIKA (PRZY CZĘŚCIACH DO SILNIKA)
- NUMER CZĘŚCI ZAMIEWNNEJ
- ZAMAWIANA ILOŚĆ

E 3055-1002

Position Ref.No. Repère Posizione Posicion	Menge Quantity Quantité Quantità Cantidad	Teile-Nr. Part-No. No. Référence Nr. d'Ordine No. Referenzia	Hinweis Hints Indications Indicazione Indicaciones	Position Ref. No. Repère Posizione Posicion	Menge Quantity Quantité Quantità Cantidad	Teile-Nr. Part-No. No. Référence Nr. d'Ordine No. Referenzia	Hinweis Hints Indications Indicazione Indicaciones
1	1	10016226	CF4				
1	1	10022576	CF4/60				
2	4	20004004					
3	4	25049011	DIN7349-13x30x6				
4	4	20029004	VSK 12				
5	4	25031027	DIN1587-M12				
6	4	20029023	SKB 12				
7	4	25031005	DIN934-M12				
8	1	10001418					
9	6	20029004	VSK 12				
10	6	25044071	DIN912-M12x75				
11	1	20013277					

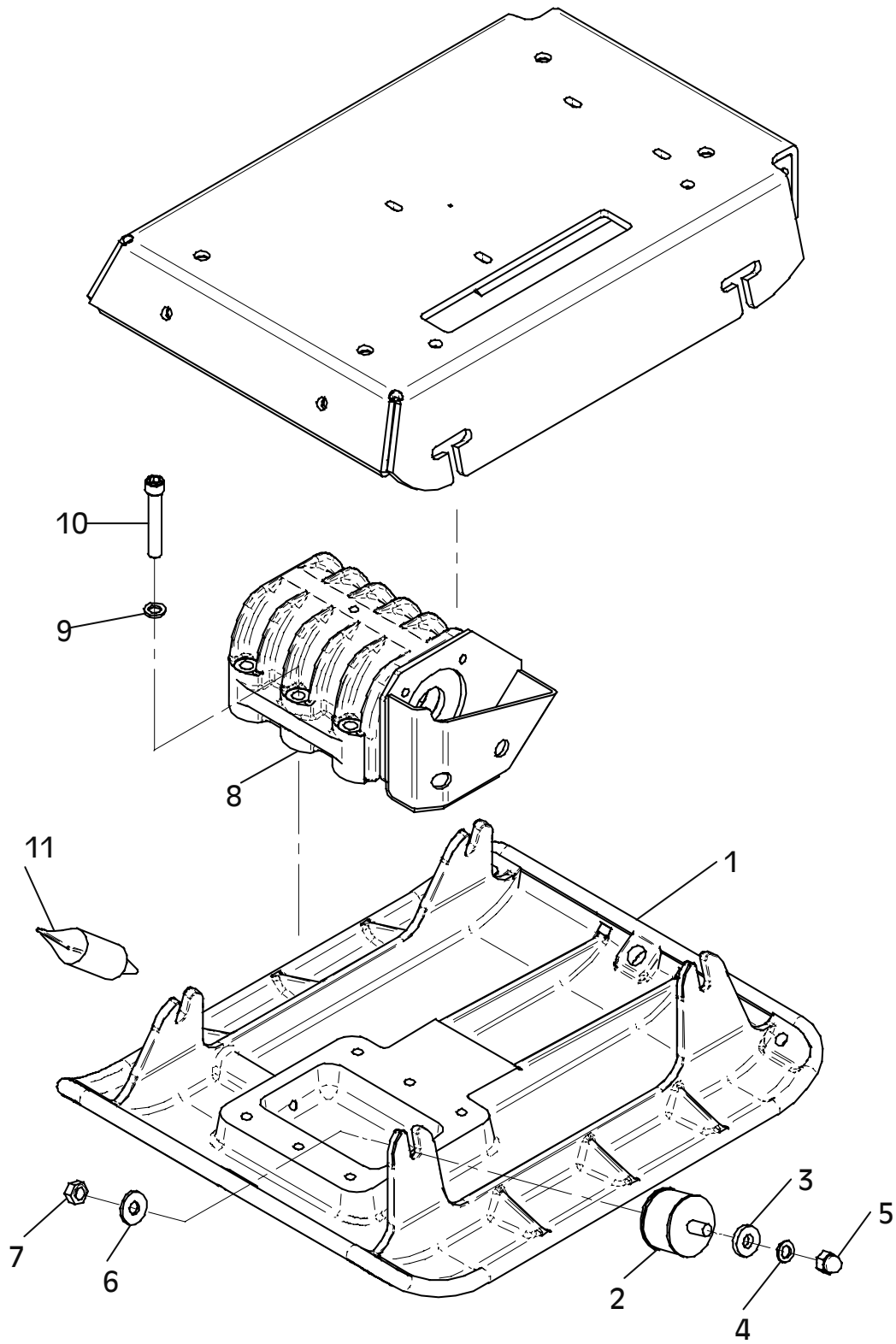

E 3055-1002

E 3056-1002

Position Ref.No. Repère Posizione Posicion	Menge Quantity Quantité Quantità Cantidad	Teile-Nr. Part-No. No. Référence Nr. d'Ordine No. Referenzia	Hinweis Hints Indications Indicazione Indicaciones	Position Ref. No. Repère Posizione Posicion	Menge Quantity Quantité Quantità Cantidad	Teile-Nr. Part-No. No. Référence Nr. d'Ordine No. Referenzia	Hinweis Hints Indications Indicazione Indicaciones
1	1	10016182					
2	1	25030001	DIN908-M10x1				
3	1	10022244					
4	4	20029003	VSK 8				
5	4	25046023	DIN7984-M8x20				
6	1	20013008					
7	1	10005404					
8	4	20029003	VSK 8				
9	4	25044005	DIN912-M8x20				
10	1	10016185					
11	1	10016186					
12	2	20029026					
13	2	25044040	DIN912-M12x60				
14	2	25001152					
15	0	20025162					
16	0	20025163					
17	0	20025561					
18	1	25017007					
19	1	10016189					
20	1	20029022	SKB 10				
21	1	10007370					

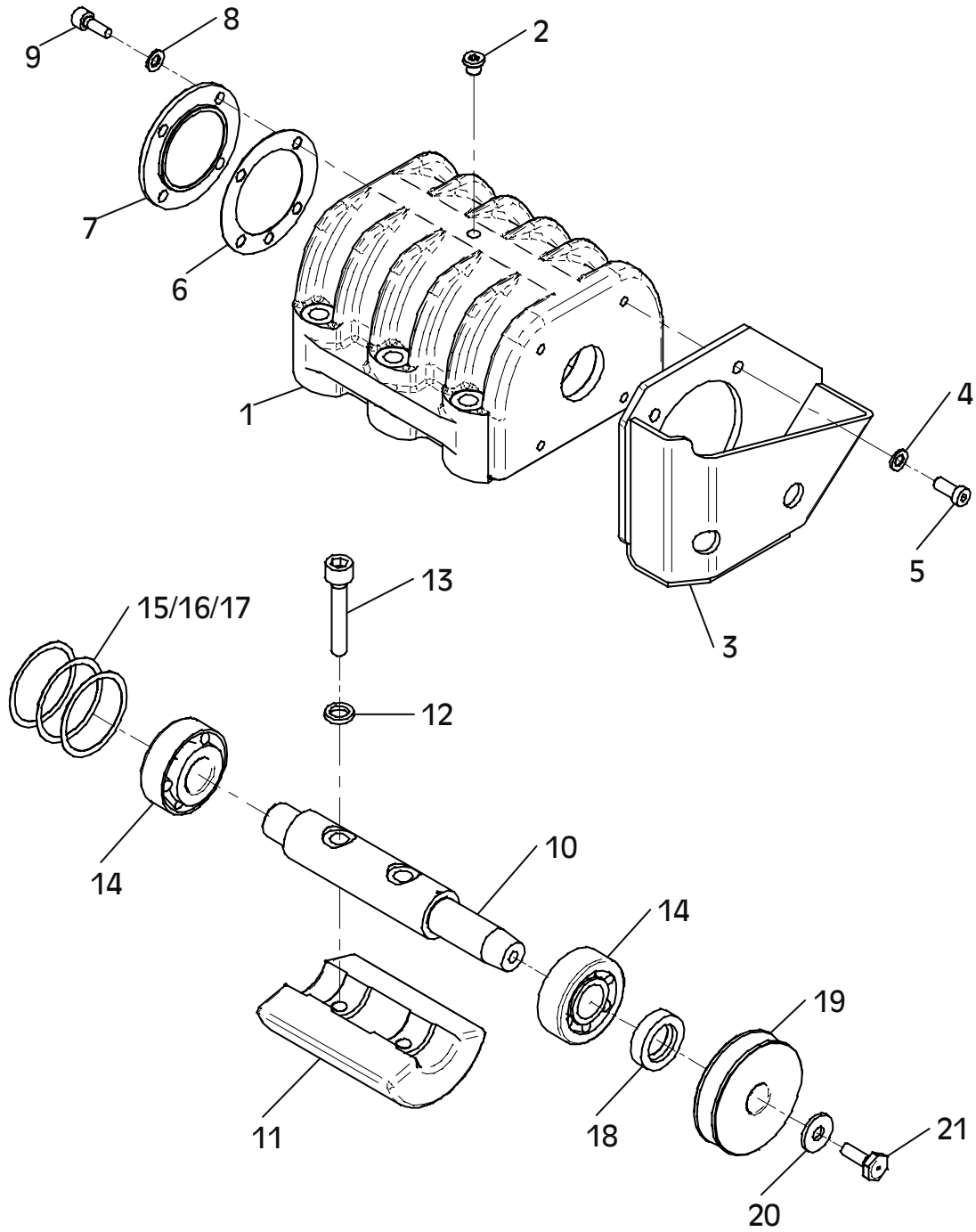

E 3056-1002

E 3057-0403

Position Ref.No. Repère Posizione Posicion	Menge Quantity Quantité Quantità Cantidad	Teile-Nr. Part-No. No. Référence Nr. d'Ordine No. Referenzia	Hinweis Hints Indications Indicazione Indicaciones	Position Ref. No. Repère Posizione Posicion	Menge Quantity Quantité Quantità Cantidad	Teile-Nr. Part-No. No. Référence Nr. d'Ordine No. Referenzia	Hinweis Hints Indications Indicazione Indicaciones
1	1	10022242		30	4	25048004	DIN125-A13
2	1	20001203		31	4	20029004	VSK 12
3	4	25033012	DIN603-M8x25	32	4	25038020	DIN933-M12x30
4	4	20029024		33	1	10016359	
5	4	25031003	DIN934-M8	34	1	20018020	
6	1	20002072		35	2	20029007	VSK 6
7	1	25002093		36	2	25040067	DIN931-M6x30
8	1	25048009	9/28x3	37	1	20018021	
9	1	20029003	VSK 8	38	1	20006418	
10	1	25038007	DIN933-M8x20	39	1	2007007	
11	1	10016188		40	1	25048001	DIN125-B6,4
12	2	25048003	DIN125-A10,5	41	1	25044003	DIN912-M6x20
13	2	20029012	VSKZ 10	42	2	25031002	DIN934-M6
14	2	25044013	DIN912-M10x30	43	2	25048001	DIN125-B6,4
15	2	20005010		44	1	40031335	
16	2	20029003	VSK 8	45	1	40031336	
17	2	25038073	DIN933-M8x12	46	1	40031334	
18	1	25008017		47	1	40031514	
19	1	20025765		48	2	25048001	DIN125-B6,4
20	1	20025590					
21	1	10022510					
22	2	10016261					
23	2	20025015					
24	2	25049011	DIN7349-13x30x6				
25	2	20029013	VSKZ 12				
26	2	25044066	DIN912-M12x90				
27	1	25033008	DIN603-M6x20				
28	2	25031012	DIN985-M6				
29	1	10022606					

Hatz

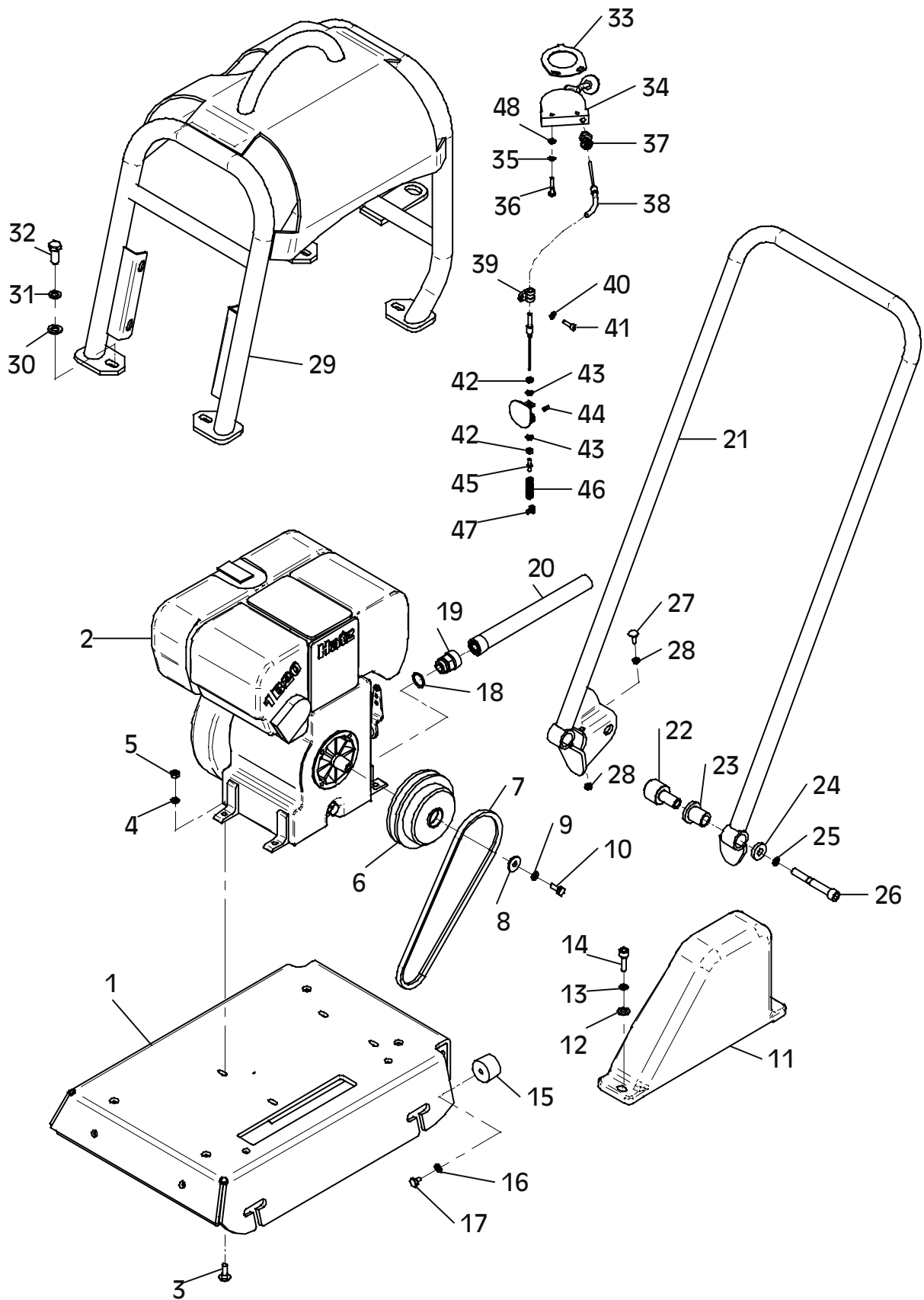

E 3057-0403

E 3058-1002

Position Ref.No. Repère Posizione Posicion	Menge Quantity Quantité Quantita Cantidad	Teile-Nr. Part-No. No. Référence Nr. d'Ordine No. Referenzia	Hinweis Hints Indications Indicazione Indicaciones	Position Ref. No. Repère Posizione Posicion	Menge Quantity Quantité Quantita Cantidad	Teile-Nr. Part-No. No. Référence Nr. d'Ordine No. Referenzia	Hinweis Hints Indications Indicazione Indicaciones
1	1	20002072					
2	1	20002231					
3	2	20002255					

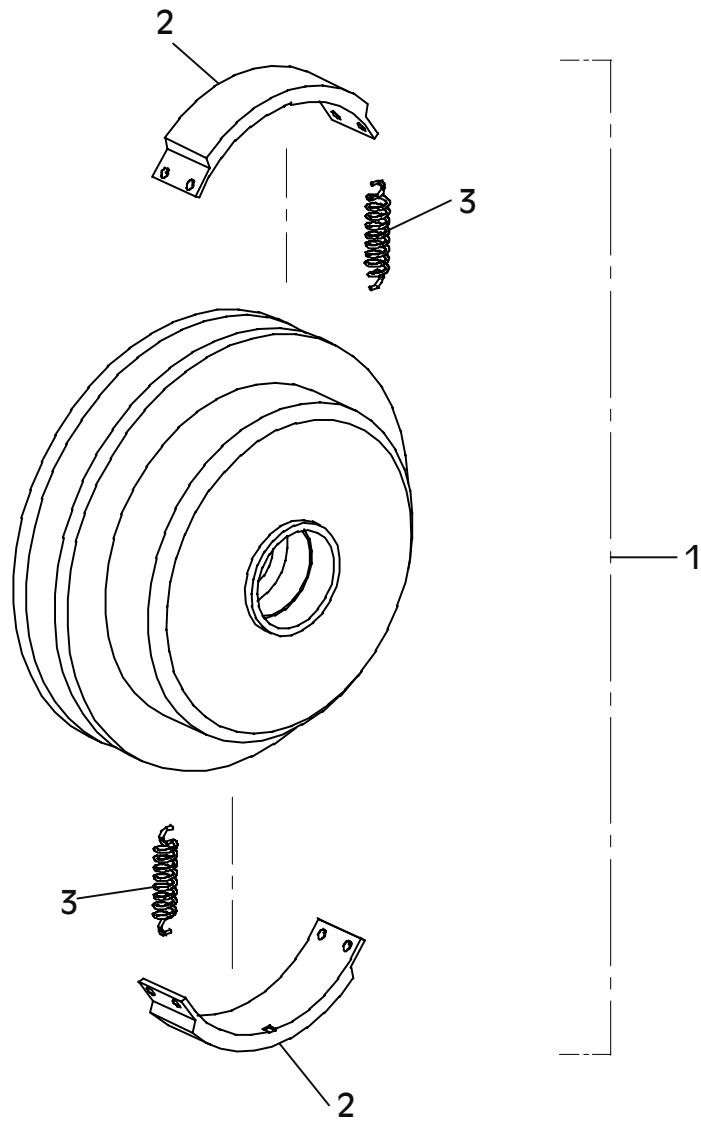

E 3058-1002

E 3059-1002

Position Ref.No. Repère Posizione Posicion	Menge Quantity Quantité Quantità Cantidad	Teile-Nr. Part-No. No. Référence Nr. d'Ordine No. Referenzia	Hinweis Hints Indications Indicazione Indicaciones	Position Ref. No. Repère Posizione Posicion	Menge Quantity Quantité Quantità Cantidad	Teile-Nr. Part-No. No. Référence Nr. d'Ordine No. Referenzia	Hinweis Hints Indications Indicazione Indicaciones
1	1	10022511		30	2	25044066	DIN912-M12x90
2	1	10016289		31	1	25033008	DIN603-M6x20
3	2	25041057	DIN933-M10x25	32	2	25031012	DIN985-M6
4	2	20029001	VSK 10	33	1	10022512	
5	2	25049005	DIN440-R11,5	34	4	25048004	DIN125-A13
6	1	20001039		35	4	20029004	VSK 12
7	4	25025185		36	4	25038020	DIN933-M12x30
8	4	25049026	DIN7349-8,4				
9	4	20029024					
10	4	25031003	DIN934-M8				
11	1	20002098					
12	1	10005238					
13	1	25002173					
14	1	10016312					
15	1	25049016	DIN440-R9				
16	1	20029003	VSK 8				
17	1	25044005	DIN912-M8x20				
18	1	10015989					
19	2	25048003	DIN125-A10,5				
20	2	20029012	VSKZ 10				
21	2	25044013	DIN912-M10x30				
22	2	20005010					
23	2	20029003	VSK 8				
24	2	25038073	DIN933-M8x12				
25	1	10022510					
26	2	10016261					
27	2	20025015					
28	2	25049011	DIN7349-13x30x6				
29	2	20029013	VSKZ 12				

Robin

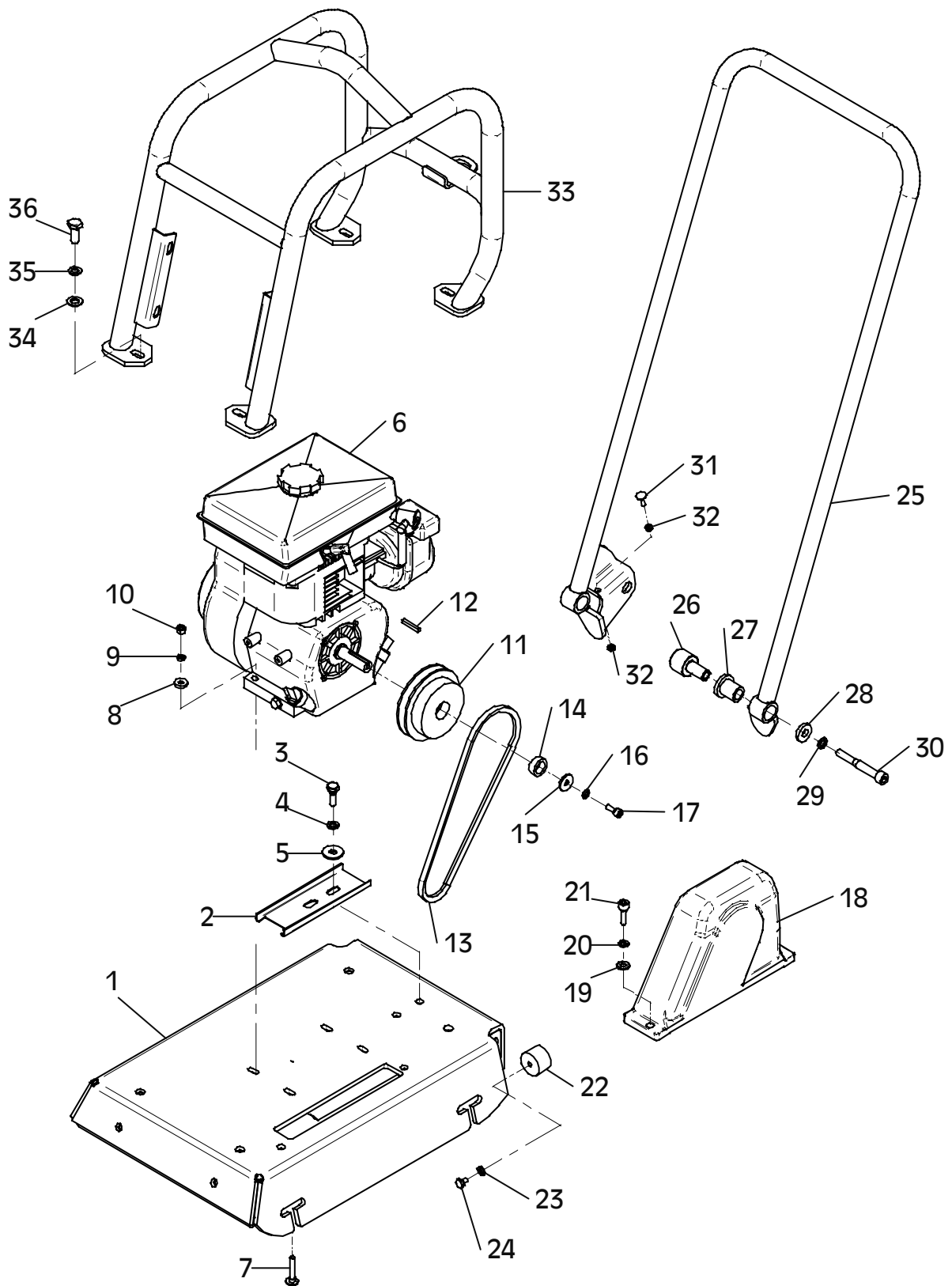

E 3059-1002

E 3140-0304

Position Ref.No. Repère Posizione Posicion	Menge Quantity Quantité Quantita Cantidad	Teile-Nr. Part-No. No. Référence Nr. d'Ordine No. Referenzia	Hinweis Hints Indications Indicazione Indicaciones	Position Ref. No. Repère Posizione Posicion	Menge Quantity Quantité Quantita Cantidad	Teile-Nr. Part-No. No. Référence Nr. d'Ordine No. Referenzia	Hinweis Hints Indications Indicazione Indicaciones
1	1	20002098					
2	2	20002285					
3	2	20002549					

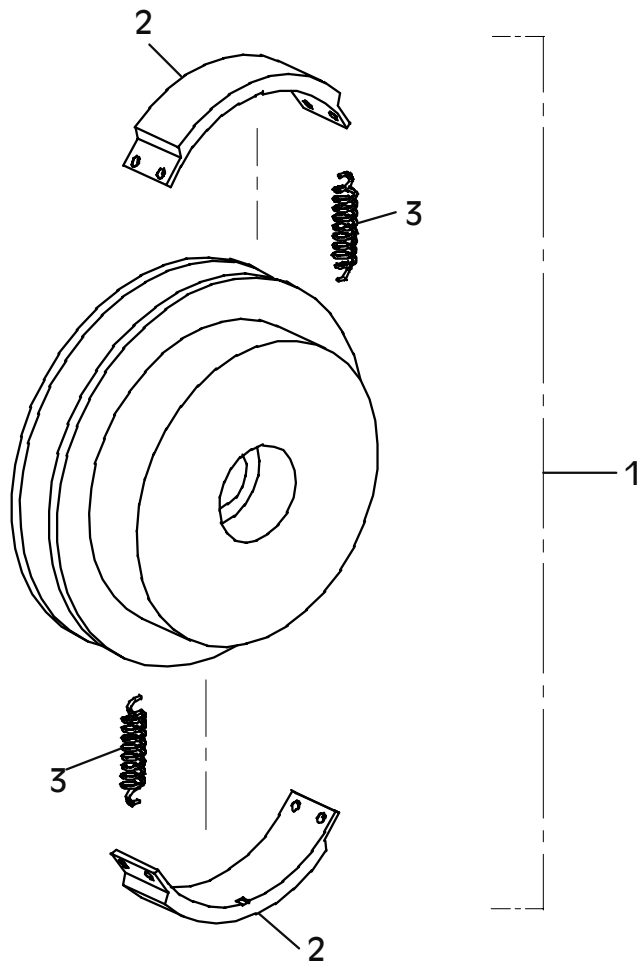

E 3140-0304

E 3061-1002

Position Ref.No. Repère Posizione Posicion	Menge Quantity Quantité Quantità Cantidad	Teile-Nr. Part-No. No. Référence Nr. d'Ordine No. Referenzia	Hinweis Hints Indications Indicazione Indicaciones	Position Ref. No. Repère Posizione Posicion	Menge Quantity Quantité Quantità Cantidad	Teile-Nr. Part-No. No. Référence Nr. d'Ordine No. Referenzia	Hinweis Hints Indications Indicazione Indicaciones
1	1	10022511		30	2	25044066	DIN912-M12x90
2	1	10016289		31	1	25033008	DIN603-M6x20
3	2	25049005	DIN440-R11,5	32	2	25031012	DIN985-M6
4	2	20029001	VSK 10	33	1	10022512	
5	2	25041057	DIN933-M10x25	34	4	25048004	DIN125-A13
6	1	20001208		35	4	20029004	VSK 12
7	1	10022203		36	4	25038020	DIN933-M12x30
8	4	25025185					
9	4	25049026	DIN7349-8,4				
10	4	20029024					
11	4	25031003	DIN934-M8				
12	1	20002102					
13	1	10015738					
14	1	10005238					
15	1	25002173					
16	1	20029021	SKB 8				
17	1	25043005	DIN933-5/16"				
18	1	10015989					
19	2	25048003	DIN125-A10,5				
20	2	20029012	VSKZ 10				
21	2	25044013	DIN912-M10x30				
22	2	20005010					
23	2	20029003	VSK 8				
24	2	25038073	DIN933-M8x12				
25	1	10022510					
26	2	10016261					
27	2	20025015					
28	2	25049011	DIN7349-13x30x6				
29	2	20029013	VSKZ 12				

Honda

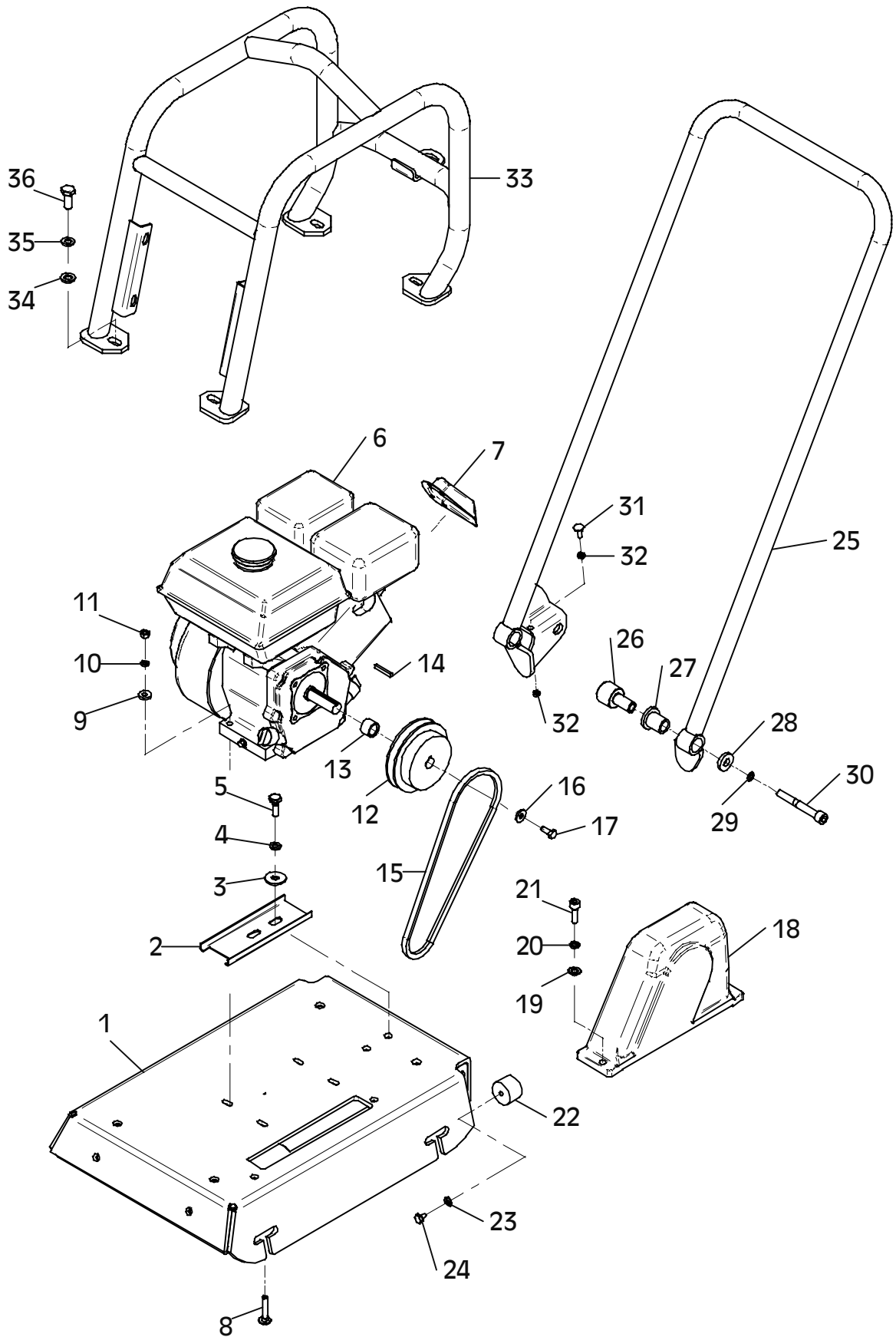

E 3061-1002

E 3176-0704

Position Ref.No. Repère Posizione Posicion	Menge Quantity Quantité Quantita Cantidad	Teile-Nr. Part-No. No. Référence Nr. d'Ordine No. Referenzia	Hinweis Hints Indications Indicazione Indicaciones	Position Ref. No. Repère Posizione Posicion	Menge Quantity Quantité Quantita Cantidad	Teile-Nr. Part-No. No. Référence Nr. d'Ordine No. Referenzia	Hinweis Hints Indications Indicazione Indicaciones
1	1	20002102					
2	2	20002337					
3	2	20002223					

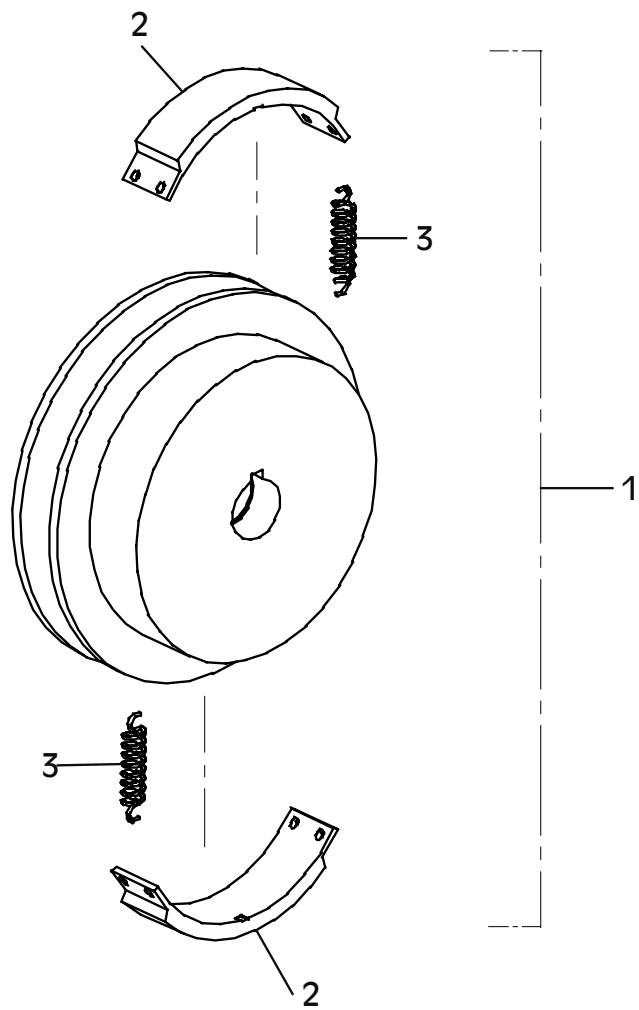

E 3176-0704

E 3063-1002

Position Ref.No. Repère Posizione Posicion	Menge Quantity Quantité Quantita Cantidad	Teile-Nr. Part-No. No. Référence Nr. d'Ordine No. Referenzia	Hinweis Hints Indications Indicazione Indicaciones	Position Ref. No. Repère Posizione Posicion	Menge Quantity Quantité Quantita Cantidad	Teile-Nr. Part-No. No. Référence Nr. d'Ordine No. Referenzia	Hinweis Hints Indications Indicazione Indicaciones
1	1	20026461					
2	1	20025719					
3	4	25048003	DIN125-A10,5				
4	4	20029001	VSK 10				
5	4	25044041	DIN912-M10x20				
6	1	25048006	DIN125-A21				
7	1	20030018					
8	1	20025438					
9	1	20030010					
10	1	10016271					
11	1	10022509					
12	2	20029022	SKB 10				
13	2	25038014	DIN933-M10x25				
14	2	25030003	DIN908-M24x1,5				

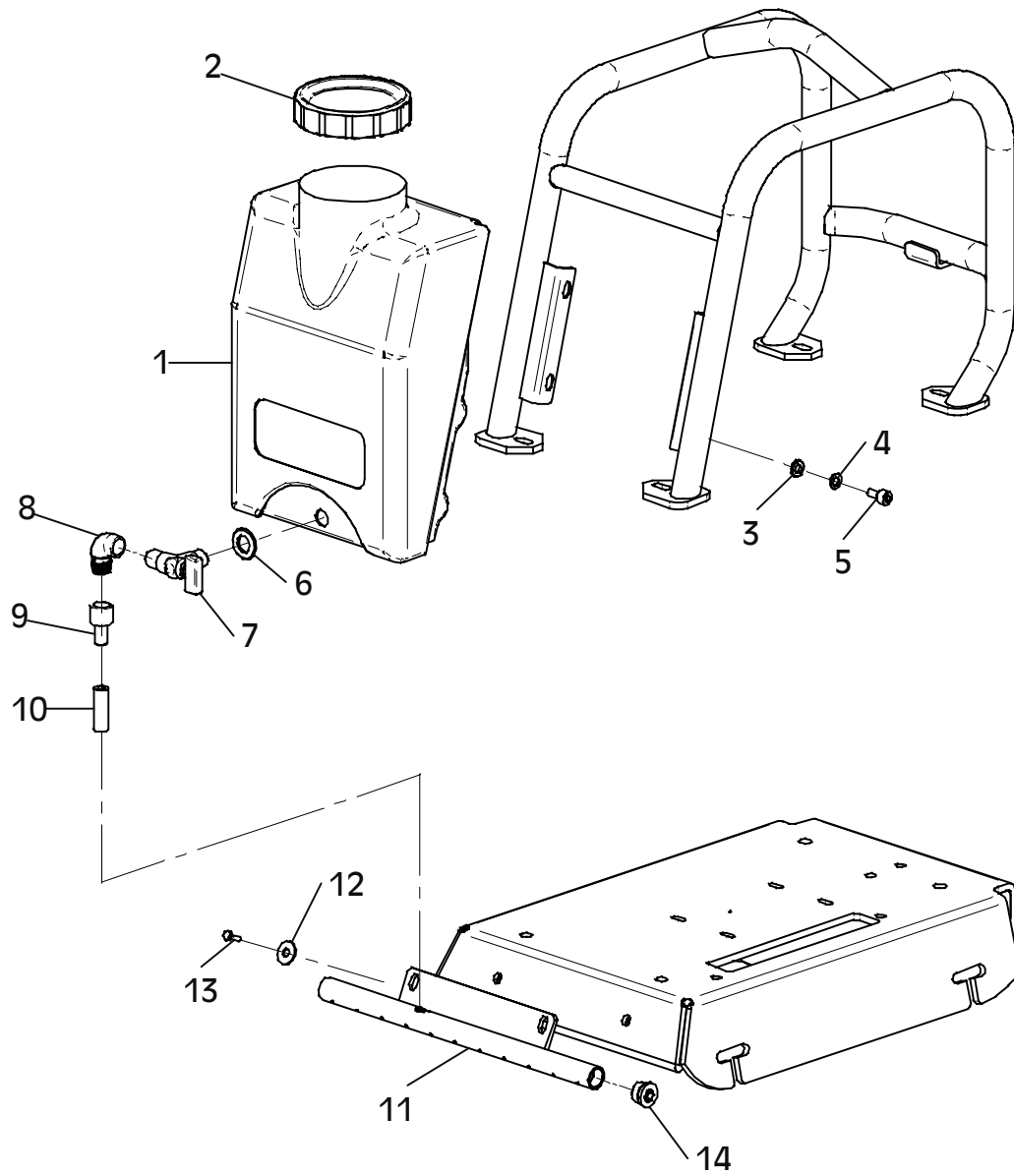

E 3063-1002

E 3064-0903

Position Ref.No. Repère Posizione Posicion	Menge Quantity Quantité Quantità Cantidad	Teile-Nr. Part-No. No. Référence Nr. d'Ordine No. Referenzia	Hinweis Hints Indications Indicazione Indicaciones	Position Ref. No. Repère Posizione Posicion	Menge Quantity Quantité Quantità Cantidad	Teile-Nr. Part-No. No. Référence Nr. d'Ordine No. Referenzia	Hinweis Hints Indications Indicazione Indicaciones
1	1	10016272					
2	1	10016350					
3	3	25038060	DIN933-M10x50				
4	3	25048003	DIN125-A10,5				
5	3	20022003	Tensilock M10				
6	1	10022507					
7	2	25048010	DIN1440-11x25x3				
8	2	20029001	VSK 10				
9	2	25038015	DIN933-M10x30				
10	1	20005009					
11	1	20029021	SKB 8				
12	1	25031003	DIN934-M8				
13	1	20026465					
14	2	25025191					
15	1	20025019					
16	1	10022508					
17	1	10016041					
18	2	20026466					
19	1	25036024					
20	2	20026272					
21	2	25048006	DIN125-A21				
22	2	20008088					
23	1	20026481					
24	2	25025191					
25	1	20025019					

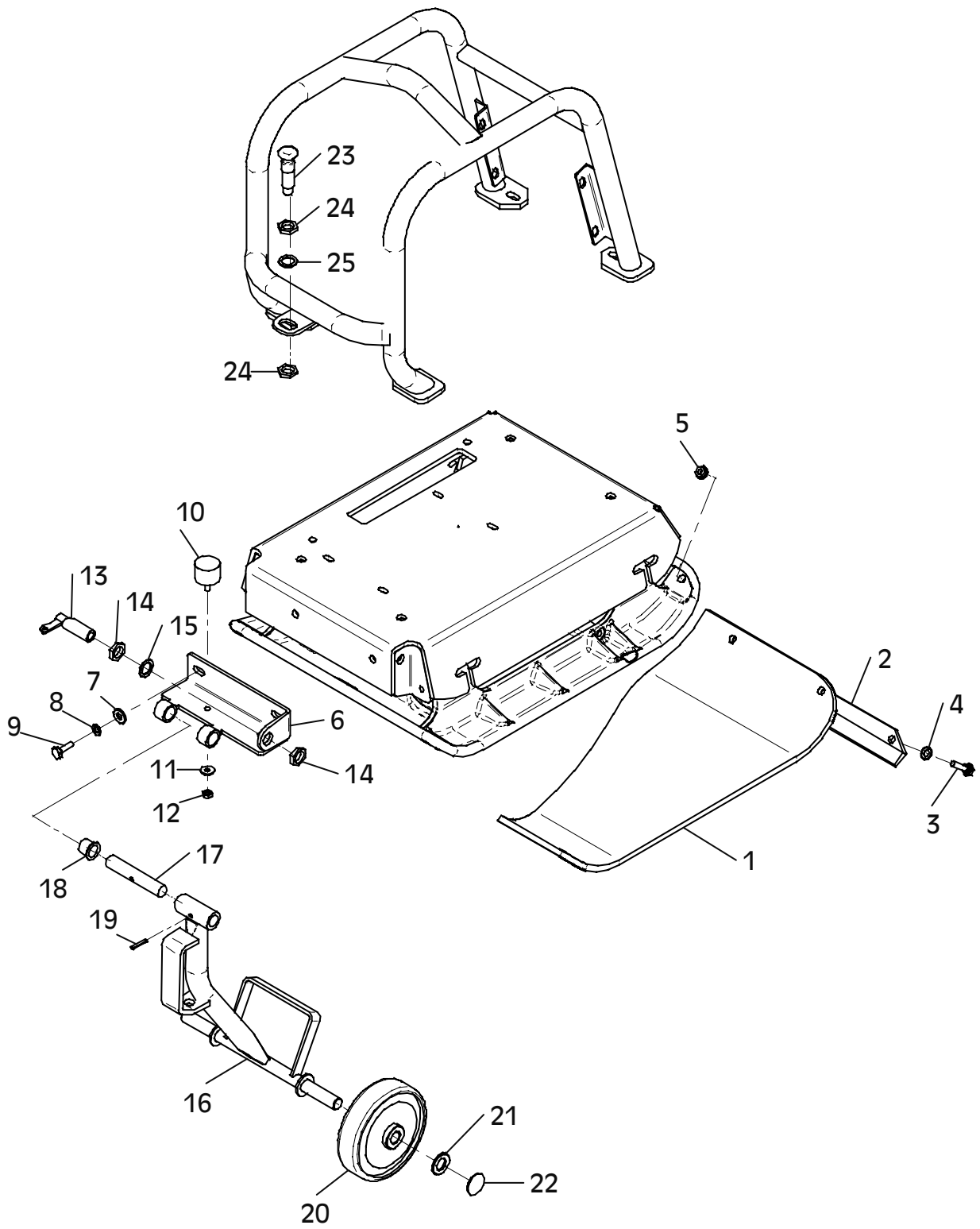

E 3064-0903

E 3065-1102

Position Ref.No. Repère Posizione Posicion	Menge Quantity Quantité Quantità Cantidad	Teile-Nr. Part-No. No. Référence Nr. d'Ordine No. Referenzia	Hinweis Hints Indications Indicazione Indicaciones	Position Ref. No. Repère Posizione Posicion	Menge Quantity Quantité Quantità Cantidad	Teile-Nr. Part-No. No. Référence Nr. d'Ordine No. Referenzia	Hinweis Hints Indications Indicazione Indicaciones
1	1	10016908					
2	1	10016350					
3	3	25038060	DIN933-M10x50				
4	3	25048003	DIN125-A10,5				
5	3	20022003	Tensilock M10				

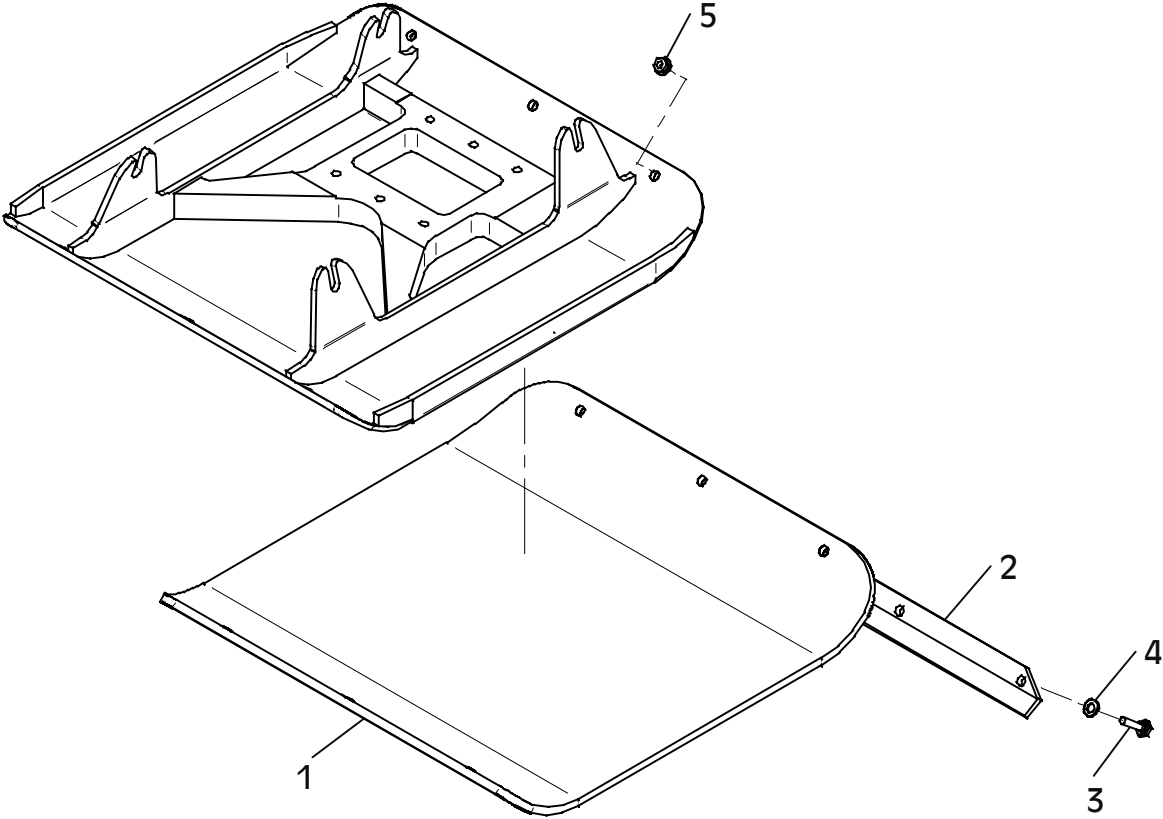

**Wenn Sie Fragen und Anregungen haben, oder sonstige Informationen benötigen,
wenden Sie sich bitte an eine der unten genannten Adressen:**

**For questions and further information refer to one of the
following addresses:**

<p>In Deutschland In Germany</p>	<p>WEBER Maschinenteknik GmbH Postfach 2153 57329 Bad Laasphe – Rückershausen Information / information: E-mail: info@webermt.de Ersatzteile / spare parts: E-mail: parts@webermt.de</p>	<p>Telefon / phone: Telefax / fax: Telefax / fax:</p>	<p>+49 (0) 2754 / 3980 Zentrale / switchboard +49 (0) 2754 / 398101 Zentrale / switchboard +49 (0) 2754 / 398102 Ersatzteile / spare parts direct dial</p>
<p>In Holland In Netherlands</p>	<p>WEBER Maschinenteknik B.V. Graafschap Hornelaan 159 6001 AC Weert E-mail: info@webermt.nl</p>	<p>Telefon / phone: Telefax / fax:</p>	<p>+31 (0) 495 / 530215 +31 (0) 495 / 541839</p>
<p>In Frankreich In France</p>	<p>WEBER Technologie S.A.R.L. 26, rue d' Arsonval 69680 Chassieu E-mail: france@webermt.com</p>	<p>Telefon / phone: Telefax / fax:</p>	<p>+33 (0) 472 / 791020 +33 (0) 472 / 791021</p>
<p>In Polen In Poland</p>	<p>WEBER Maschinenteknik SP.ZO.O. ul. Grodziska 7 05-830 Stara Wies / Nadarzyn E-mail: info@webermt.com.pl</p>	<p>Telefon / phone: Telefax / fax:</p>	<p>+48 (0) 22 / 7397080 +48 (0) 22 / 7397081 +48 (0) 22 / 7397082</p>
<p>In USA, Kanada In USA, Canada</p>	<p>WEBER Machine (USA), Inc. 40 Johnson Ave 112 Bangor, ME 04401 USA E-mail: usa@webermt.com</p>	<p>Telefon / phone: Telefax / fax:</p>	<p>+1 (0) 207 / 9474990 +1 (0) 207 / 9475452</p>
<p>In Südamerika In South America</p>	<p>WEBER Maschinenteknik do Brasil Ltda. Rua Sete de Setembro, 275 93332-470 Novo Hamburgo, RS Brasil E-mail: webermt@webermt.com.br</p>	<p>Telefon / phone: Telefax / fax:</p>	<p>+55 (0) 51 / 5873044 +55 (0) 51 / 5872271</p>

<http://www.webermt.com>

