



ERSATZTEILLISTE

SPARE PARTS LIST

**LISTE DES PIECES
DE RECHANGE**

LISTINO RICAMBI

LISTA DE RECAMBIOS

**WYKAZ CZESCI
ZAMIENNYCH**



CR 1

0115501-0115506

Ab Masch.-Nr. 7009816



Weber Maschinenteknik GmbH

Postfach 2153, 57329 Bad Laasphe-Rückershausen

Telefon 02754 / 398-0

Telefax (02754) 398-101 (Zentrale) u. 398-102 (Ersatzteile)

EG - KONFORMITÄTSERKLÄRUNG

EC DECLARATION OF CONFORMITY/ DECLARATION DE CONFORMITE CE
DICHIARAZIONE CE DI CONFORMITA / DECLARACION CE DE CONFORMIDAD
EG-VERKLARING VAN OVEREENSTEMMING / EF-OVERENSSTEMMELSESERKAERING
DECLARACAO CE DE CONFORMIDADE / EG-FÖRSÄKRAN OM ÖVERENSSTÄMMELSE
DEKLARACJA ZGODNOŚCI[TK5]

im Sinne der EG-Maschinenrichtlinie 98/37/EG
und der EG Richtlinie 2000/14/EG – Geräuschemissionen

- I **Hersteller/** Make / Marque / Marca / Marca / Producent / Merk / Marca /
Tillverkare / Producent **Weber Maschinentechnik GmbH**
Im Boden 5-8,10
57334 Bad Laasphe
- II **Art /** Category / Catégorie / Categoria Tipo / Kategori /
Soort / Categoria / kategori / Typ **Vibrationsplatte**
- III **Typ /** Type / Type / Tipo / Codice / Type / Type / Tipo / Typ / **CR 1**
- IV **Nennleistung /** Nominal-performance / La puissance nominale / Prestazione nominale /
Potencia nominal / Nominaal vermogen / Nominel ydelse / Potência nominal / Nominell
effect / Moc **P = 3,5 kW**
- V **gemessener Schalleistungspegel /** measured sound power level / niveau de
puissance acoustique mesure / livello di potenza sonora rilevato / nivel de potencia
acústica medido / gemeten geluidsvermogensniveau / målt lydeffektniveau / Nivel de
potência sonora midido / uppmått ljudeffektnivå / Mierzony poziom dźwięku **LWA = 107 dB (A)**
- VI **garantierter Schalleistungspegel /** guaranteed sound power level / niveau de
puissance acoustique garanti / livello di potenza sonora garantito / nivel de potencia
acustica garantizado / gewaarborgd geluidsvermogensniveau / garanteret lydeffektniveau /
Nivel sonoro garantido / garanterad ljudeffektniva / Natężenie hałas **LWA = 108 dB (A)**
- VII **beteiligte Zertifizierungsstelle /** notified body involved / de l'organisme notifié/
dell'organismo notificato che l'ha effettuata / dirección del organismo notificado que haya
intervenido / betrokken aangemelde instantie / pågældende bemyndigede organ /
organismo notificado involucrado / berörda anmälda organets namn / Jednostka
certyfikująca **RWTÜV**
Postfach 103161
D-45032 Essen
- VIII **Konformitäts-Bewertungsverfahren /** Conformity assessment procedure followed /
la procédure appliquée pour l'évaluation de la conformité et / procedura di valutazione
della conformità / procedimiento de evaluación de la conformidad / gevolgde
overeenstemmingsbeoordelingsprocedure / den fulgte
overensstemmelssesvurderingsprocedure / procedimento de avaliação de conformidade
/Vilket förfarande för bedömning av överensstämmelse / Przebieg kontroli **interne Fertigungskontrolle**
nach Anhang VI
EG Richtlinie 2000/14/EG

ist in Übereinstimmung mit folgenden Richtlinien hergestellt worden /has been produced in accordance with following standards / est produit conforme aux dispositions des directives européennes ci-apres / ha sido fabricado en conformidad con las siguientes normas / é stato fabbricato in conformità alle sequenti norme / er blevet fremstillet i overensstemmelse med følgende retningslinier / in overeenstemming met de volgende voorschriften gefabriceerd is / é fabricado conforme as seguintes normas / har tillverkats i överensstämmelse med följande riktlinjer / Zgodność z obowiązującymi przepisami

98/37/EG	Maschinenrichtlinie des europäischen Parlamentes und des Rates vom 22. Juni 1998
2000/14/EG	EG-Richtlinie Geräuschemissionen vom 8. Mai 2000
2005/88/EG	EG-Richtlinie vom 14. Dez. 2005 zur Änderung der Richtlinie 2000/14/EG
EN 500 Teil 1	Bewegliche Straßenbaumaschinen – Sicherheit Gemeinsame Anforderungen
EN 500 Teil 4	Bewegliche Straßenbaumaschinen – Sicherheit Besondere Anforderungen an Verdichtungsmaschinen

Bescheinigung bitte sorgfältig aufbewahren / File certificate carefully / Conserver certificat soigneusement / Conserver certificado cuidadosamente / Pregasi conservare accuratamente certificato / Beviset bedes opbevares omhyggeligt / Verklaring a.u.b. zorgvuldig bevare / Conservar o certificado com cuidado / Beviset skall om sorgsfullt bevaras // Deklarację zgodności proszę zachować

Bad Laasphe – Rückershausen, den **02.01.2008**

W. Weber, Geschäftsführer

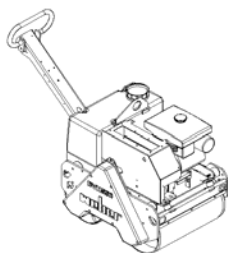

weberm

WEBER Maschinentechnik GmbH
Im Boden 5-8, 10 – D-57334 Bad Laasphe
Postfach 2153 – D-57329 Bad Laasphe
Telefon: 02754/398-0 – Fax 02754/398-101
E-mail: Verkauf@webermt.de
Internet: <http://www.webermt.de>



EG - KONFORMITÄTSEKKLÄRUNG

EC DECLARATION OF CONFORMITY/ DECLARATION DE CONFORMITE CE
DICHIARAZIONE CE DI CONFORMITA / DECLARACION CE DE CONFORMIDAD
EG-VERKLARING VAN OVEREENSTEMMING / EF-OVERENSSTEMMELSESEKKAERING
DECLARACAO CE DE CONFORMIDADE / EG-FÖRSÄKRAN OM ÖVERENSSTÄMMELSE
DEKLARACJA ZGODNOŚCI[TK5]

im Sinne der EG-Maschinenrichtlinie 98/37/EG
und der EG Richtlinie 2000/14/EG – Geräuschemissionen

- I **Hersteller/ Make / Marque / Marca / Marca / Producent / Merk / Marca /**
Tillverkare / Producent **Weber Maschinentechnik GmbH**
Im Boden 5-8,10
57334 Bad Laasphe
- II **Art / Category / Catégorie / Categoria Tipo / Kategori /**
Soort / Categoria / kategori / Typ **Vibrationsplatte**
- III **Typ / Type / Type / Tipo / Codice / Type / Type / Tipo / Typ /**
CR 1 R
- IV **Nennleistung / Nominal-performance / La puissance nominale / Prestazione nominale /**
Potencia nominal / Nominaal vermogen / Nominel ydelse / Potência nominal / Nominell
effect / Moc **P = 3,4 kW**
- V **gemessener Schalleistungspegel / measured sound power level / niveau de**
puissance acoustique mesure / livello di potenza sonora rilevato / nivel de potencia
acústica medido / gemeten geluidsvermogensniveau / målt lydteffektivitet / Nivel de
potência sonora midido / uppmätt ljudteffektivitet / Mierzonny poziom dźwięku **LWA = 107 dB (A)**
- VI **garantierter Schalleistungspegel / guaranteed sound power level / niveau de**
puissance acoustique garanti / livello di potenza sonora garantito / nivel de potencia
acustica garantizado / gewaarborgd geluidsvermogensniveau / garanteret lydteffektivitet /
Nivel sonoro garantido / garanterad ljudteffektivitet / Natężenie hałas **LWA = 108 dB (A)**
- VII **beteiligte Zertifizierungsstelle / notified body involved / de l'organisme notifié/**
dell'organismo notificato che l'ha effettuata / dirección del organismo notificado que haya
intervenido / betrokken aangemelde instantie / pagældende bemyndigede organ /
organismo notificado involucrado / berörda anmälda organets namn / Jednostka
certyfikująca **RWTÜV**
Postfach 103161
D-45032 Essen
- VIII **Konformitäts-Bewertungsverfahren / Conformity assessment procedure followed /**
la procédure appliquée pour l'évaluation de la conformité et / procedura di valutazione
della conformità / procedimiento de evaluación de la conformidad / gevolgde
overeenstemmingsbeoordelingsprocedure / den fulgte
overensstemmelsesvurderingsprocedure / procedimento de avaliação de conformidade
/vilket förfarande för bedömning av överensstämmelse / Przebieg kontroli **interne Fertigungskontrolle**
nach Anhang VI
EG Richtlinie 2000/14/EG

ist in Übereinstimmung mit folgenden Richtlinien hergestellt worden /has been produced in accordance with following
standards / est produit conforme aux dispositions des directives européennes ci-apres / ha sido fabricado en conformidad con las
siguientes normas / è stato fabbricato in conformità alle sequenti norme / er blevet fremstillet i overensstemmelse med følgende
retningslinier / in overensstemming met de volgende voorschriften gefabriceerd is / é fabricado conforme as seguintes normas / har
tillverkats i överensstämmelse med följande riktlinjer / Zgodność z obowiązującymi przepisami

98/37/EG Maschinenrichtlinie des europäischen Parlamentes und des Rates vom 22. Juni 1998
2000/14/EG EG-Richtlinie Geräuschemissionen vom 8. Mai 2000
2005/88/EG EG-Richtlinie vom 14. Dez. 2005 zur Änderung der Richtlinie 2000/14/EG
EN 500 Teil 1 Bewegliche Straßenbaumaschinen – Sicherheit
Gemeinsame Anforderungen
EN 500 Teil 4 Bewegliche Straßenbaumaschinen – Sicherheit
Besondere Anforderungen an Verdichtungsmaschinen

Bescheinigung bitte sorgfältig aufbewahren / File certificate carefully / Conserver certificat soigneusement / Conservar
certificado cuidadosamente / Pregasi conservare accuratamente certificato / Beviset bedes opbevares omhyggeligt / Verklaring
a.u.b. zorgvuldig bevare / Conservar o certificado com cuidado / Beviset skall om sorgsfullt bevaras // Deklarację zgodności proszę
zachować

Bad Laasphe – Rückershausen, den **02.01.2008**

W. Weber, Geschäftsführer

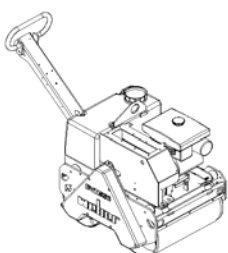

weber_{mt}

WEBER Maschinentechnik GmbH

Im Boden 5-8, 10 – D-57334 Bad Laasphe
Postfach 2153 – D-57329 Bad Laasphe
Telefon: 02754/398-0 – Fax 02754/398-101
E-mail: Verkauf@webermt.de
Internet: <http://www.webermt.de>



EG - KONFORMITÄTSERKLÄRUNG

EC DECLARATION OF CONFORMITY/ DECLARATION DE CONFORMITE CE
DICHIARAZIONE CE DI CONFORMITA / DECLARACION CE DE CONFORMIDAD
EG-VERKLARING VAN OVEREENSTEMMING / EF-OVERENSSTEMMELSESERKAERING
DECLARACAO CE DE CONFORMIDADE / EG-FÖRSÄKRAN OM ÖVERENSSTÄMMELSE
DEKLARACJA ZGODNOŚCI[TK5]

im Sinne der EG-Maschinenrichtlinie 98/37/EG
und der EG Richtlinie 2000/14/EG – Geräuschemissionen

- I **Hersteller/** Make / Marque / Marca / Marca / Producent / Merk / Marca /
Tillverkare / Producent **Weber Maschinentechnik GmbH**
Im Boden 5-8,10
57334 Bad Laasphe
- II **Art /** Category / Catégorie / Categoria Tipo / Kategori /
Soort / Categoria / kategori / Typ **Vibrationsplatte**
- III **Typ /** Type / Type / Tipo / Codice / Type / Type / Tipo / Typ / **CR 1 Hd**
- IV **Nennleistung /** Nominal-performance / La puissance nominale / Prestazione nominale /
Potencia nominal / Nominaal vermogen / Nominel ydelse / Potência nominal / Nominell
effect / Moc **P = 4,0 kW**
- V **gemessener Schalleistungspegel /** measured sound power level / niveau de
puissance acoustique mesurée / livello di potenza sonora rilevato / nivel de potencia
acústica medido / gemeten geluidsvermogensniveau / målt lydeffektniveau / Nivel de
potência sonora midido / uppmätt ljudeffektnivå / Mierzony poziom dźwięku **LWA = 106 dB (A)**
- VI **garantierter Schalleistungspegel /** guaranteed sound power level / niveau de
puissance acoustique garanti / livello di potenza sonora garantito / nivel de potencia
acustica garantizado / gewaarborgd geluidsvermogensniveau / garanteret lydeffektniveau /
Nivel sonoro garantido / garanterad ljudeffektniva / Natężenie hałas **LWA = 108 dB (A)**
- VII **beteiligte Zertifizierungsstelle /** notified body involved / de l'organisme notifié/
dell'organismo notificato che l'ha effettuata / dirección del organismo notificado que haya
intervenido / betrokken aangemelde instantie / pågældende bemyndigede organ /
organismo notificado involucrado / berörda anmälda organets namn / Jednostka
certyfikująca **RWTÜV**
Postfach 103161
D-45032 Essen
- VIII **Konformitäts-Bewertungsverfahren /** Conformity assessment procedure followed /
la procédure appliquée pour l'évaluation de la conformité et / procedura di valutazione
della conformità / procedimiento de evaluación de la conformidad / gevolgde
overeenstemmingsbeoordelingsprocedure / den fulgte
overensstemmelssesvurderingsprocedure / procedimento de avaliação de conformidade
/Vilket förfarande för bedömning av överensstämmelse / Przebieg kontroli **interne Fertigungskontrolle**
nach Anhang VI
EG Richtlinie 2000/14/EG

ist in Übereinstimmung mit folgenden Richtlinien hergestellt worden / has been produced in accordance with following standards / est produit conforme aux dispositions des directives européennes ci-apres / ha sido fabricado en conformidad con las siguientes normas / é stato fabbricato in conformità alle sequenti norme / er blevet fremstillet i overensstemmelse med følgende retningslinier / in overensstemming met de volgende voorschriften gefabriceerd is / é fabricado conforme as seguintes normas / har tillverkats i överensstämmelse med följande riktlinjer / Zgodność z obowiązującymi przepisami

98/37/EG	Maschinenrichtlinie des europäischen Parlamentes und des Rates vom 22. Juni 1998
2000/14/EG	EG-Richtlinie Geräuschemissionen vom 8. Mai 2000
2005/88/EG	EG-Richtlinie vom 14. Dez. 2005 zur Änderung der Richtlinie 2000/14/EG
EN 500 Teil 1	Bewegliche Straßenbaumaschinen – Sicherheit Gemeinsame Anforderungen
EN 500 Teil 4	Bewegliche Straßenbaumaschinen – Sicherheit Besondere Anforderungen an Verdichtungsmaschinen

Bescheinigung bitte sorgfältig aufbewahren / File certificate carefully / Conserver certificat soigneusement / Conservar certificado cuidadosamente / Pregasi conservare accuratamente certificato / Beviset bedes opbevares omhyggeligt / Verklaring a.u.b. zorgvuldig bevare / Conservar o certificado com cuidado / Beviset skall om sorgsfullt bevaras // Deklarację zgodności proszę zachować

Bad Laasphe – Rückershausen, den **02.01.2008**

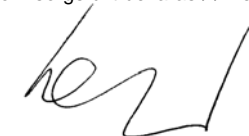

W. Weber, Geschäftsführer

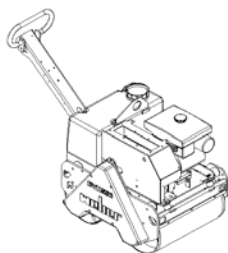

weber_{mt}

WEBER Maschinentechnik GmbH

Im Boden 5-8, 10 – D-57334 Bad Laasphe
Postfach 2153 – D-57329 Bad Laasphe
Telefon: 02754/398-0 – Fax 02754/398-101
E-mail: Verkauf@webermt.de
Internet: <http://www.webermt.de>



BITTE, NOTIEREN SIE SERIENNUMMER UND MOTORNUMMER IHRER MASCHINE:

PLEASE WRITE DOWN SERIALNUMBERS OF MACHINE AND ENGINE:

NOTEZ SVP LE NUMERO DE SERIE ET LE NUMERO DU MOTEUR DE VOTRE MACHINE:

SI PREGA DI ANNOTARE SEMPRE I NUMERI DI SERIE SIA DELLA VS. MACCHINA CHE DEL MOTORE:

MAQUINA: ROGAMOS ANOTEN EL NUMERO DE SERIE Y NUMERO DE MOTOR DE SU MAQUINA:

MASCHINE
MACHINE
MACCHINA
MAQUINA

#

MOTOR
ENGINE
MOTEUR
MOTORE

#

ZUR VERMEIDUNG VON FEHLLIEFERUNGEN UND VERZÖGERUNGEN SIND BEI DER BESTELLUNG VON ERSATZTEILEN FOLGENDE ANGABEN UNBEDINGT ERFORDERLICH:

- MASCHINENTYP
- SERIENNUMMER DER MASCHINE
- SERIENNUMMER DES MOTORS (BEI MOTORTEILEN)
- TEILENUMMER
- BESTELLMENGE

TO AVOID ERRORS IN DELIVERY PLEASE STATE THESE PARTICULARS WHEN ORDERING:

- TYPE OF MACHINE
- SERIAL NO. OF MACHINE
- SERIAL NO. OF ENGINE (ON ENGINE PARTS)
- PART-NO.
- QUANTITY REQUIRED

AFIN D'EVITER DES ERREURS DE COMMANDE ET DES RETARDS DE LIVRAISON IL EST NECESSAIRE D'INDIQUER LES CARACTERISTIQUES SUIVANTES:

- TYPE DE MACHINE
- LE NUMERO DE SERIE DE LA MACHINE
- LE NUMERO DE SERIE DU MOTEUR
- LE NUMERO D'IDENTITE DE LA PIECE
- LA QUANTITE SOUHAITEE

ONDE EVITARE DISGUIDI E RITARDI NELLE CONSEGNE DIE RICAMBI SI PREGA DI INDICARE SEMPRE:

- TIPO DELLA MACCHINA
- NUMERO DI SERIE DELLA MACCHINA
- NUMERO DI SERIE DEL MOTORE (SE SI RICHIEDONO PEZZI DEL MOTORE)
- NUMERO D'ORDINE DIE SINGOLI RICAMBI
- QUANTITA

A FI DE EVITAR ERRORES DE ENTREGA, ROGAMOS INDIQUEN LOS SIGUIENTES DATOS CUANDO PASE PEDIDOS DE RECAMBIO:

- MODELO DE MAQUINA
- NO. DE SERIE DE LA MAQUINA
- NO. DE SERIE DEL MOTOR (EN PIEZAS PARA MOTOR)
- REFERENCIA DEL RECAMBIO
- CANTIDAD PEDIDA

E 3066-0406

Position Ref.No. Repère Posizione Posicion	Menge Quantity Quantité Quantità Cantidad	Teile-Nr. Part-No. No. Référence Nr. d'Ordine No. Referenzia	Hinweis Hints Indications Indicazione Indicaciones	Position Ref. No. Repère Posizione Posicion	Menge Quantity Quantité Quantità Cantidad	Teile-Nr. Part-No. No. Référence Nr. d'Ordine No. Referenzia	Hinweis Hints Indications Indicazione Indicaciones
1	1	10016780					
2	1	25030001	DIN908-M10x1				
3	4	20004062					
4	4	20029023	SKB 12				
5	4	25031005	DIN934-M12				
6	1	10001479					
7	6	21000049	DIN912-M12x70-12.9				
8	2	25045041	DIN912-M12x140-12.9				
9	8	20029026					
10	4	20029004	VSK 12				
11	4	25038042	DIN933-M12x16				

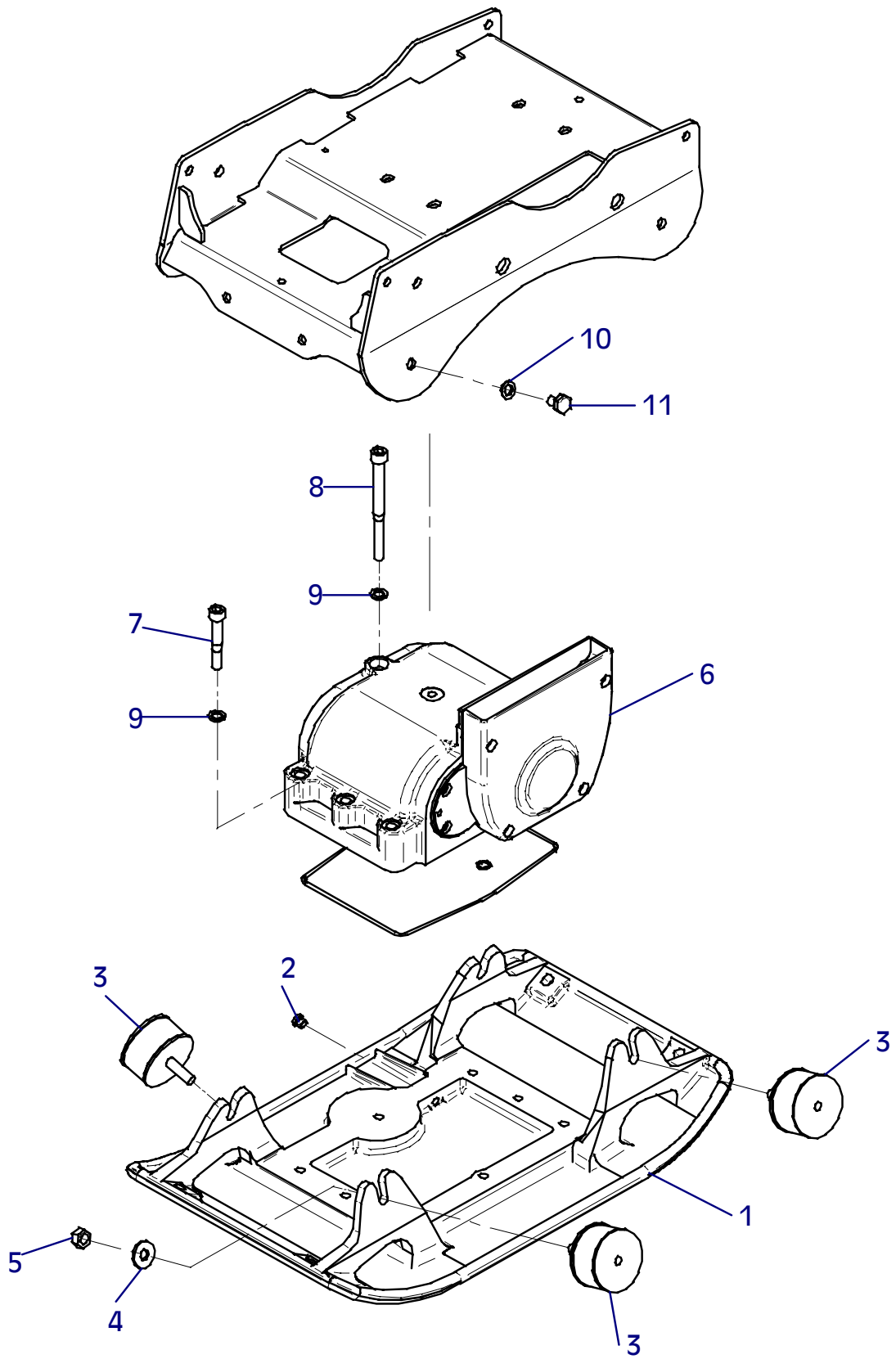

E 3066-0406

E 3067-0506

Position Ref.No. Repère Posizione Posicion	Menge Quantity Quantité Quantità Cantidad	Teile-Nr. Part-No. No. Référence Nr. d'Ordine No. Referenzia	Hinweis Hints Indications Indicazione Indicaciones	Position Ref. No. Repère Posizione Posicion	Menge Quantity Quantité Quantità Cantidad	Teile-Nr. Part-No. No. Référence Nr. d'Ordine No. Referenzia	Hinweis Hints Indications Indicazione Indicaciones
1	1	10016782		30	8	25044100	DIN912-M8x16
2	1	25038042	DIN933-M12x16	31	8	20029011	VSKZ 8
3	1	25008011	DIN7603-12x18x1,5	32	1	10017149	
4	1	10016783		33	1	20013295	
5	4	20029011	VSKZ 8	34	4	25044100	DIN912-M8x16
6	4	25044008	DIN912-M8x40	35	4	20029011	VSKZ 8
7	1	10016791		36	1	20020035	
8	1	10016071		37	1	10017152	
9	1	20029001	VSK 10	38	2	10017093	
10	1	10007370		39	2	25045028	DIN912-M10x35-10.9
11	1	10017148		40	2	20029025	
12	4	20029011	VSKZ 8	41	1	10016795	
13	4	25046015	DIN7984-M8x16	42	2	25001022	
14	1	20013295		43			
15	1	25017047		45	2	25001156	
16	2	25001156		46	1	10017154	
17	1	10017150		47	1	10008320	
18	1	10017340		48	1	25027004	DIN914-M8x16
19	1	20029026		49	1	25035026	DIN472-I28x1,2
20	1	25045037	DIN912-M12x45-10.9	50	1	25001513	
21				51	1	25034002	DIN471-A12
22	1	10016790		52	1	10016066	
23	1	25015046		53	1	20013270	
24	1	25034020	DIN471-A38x1,75	54	1	20013301	
25	0	20025561		55	2	20013103	
26	0	20025162					
27	0	20025163					
28	2	10017147					
29	2	20013295					

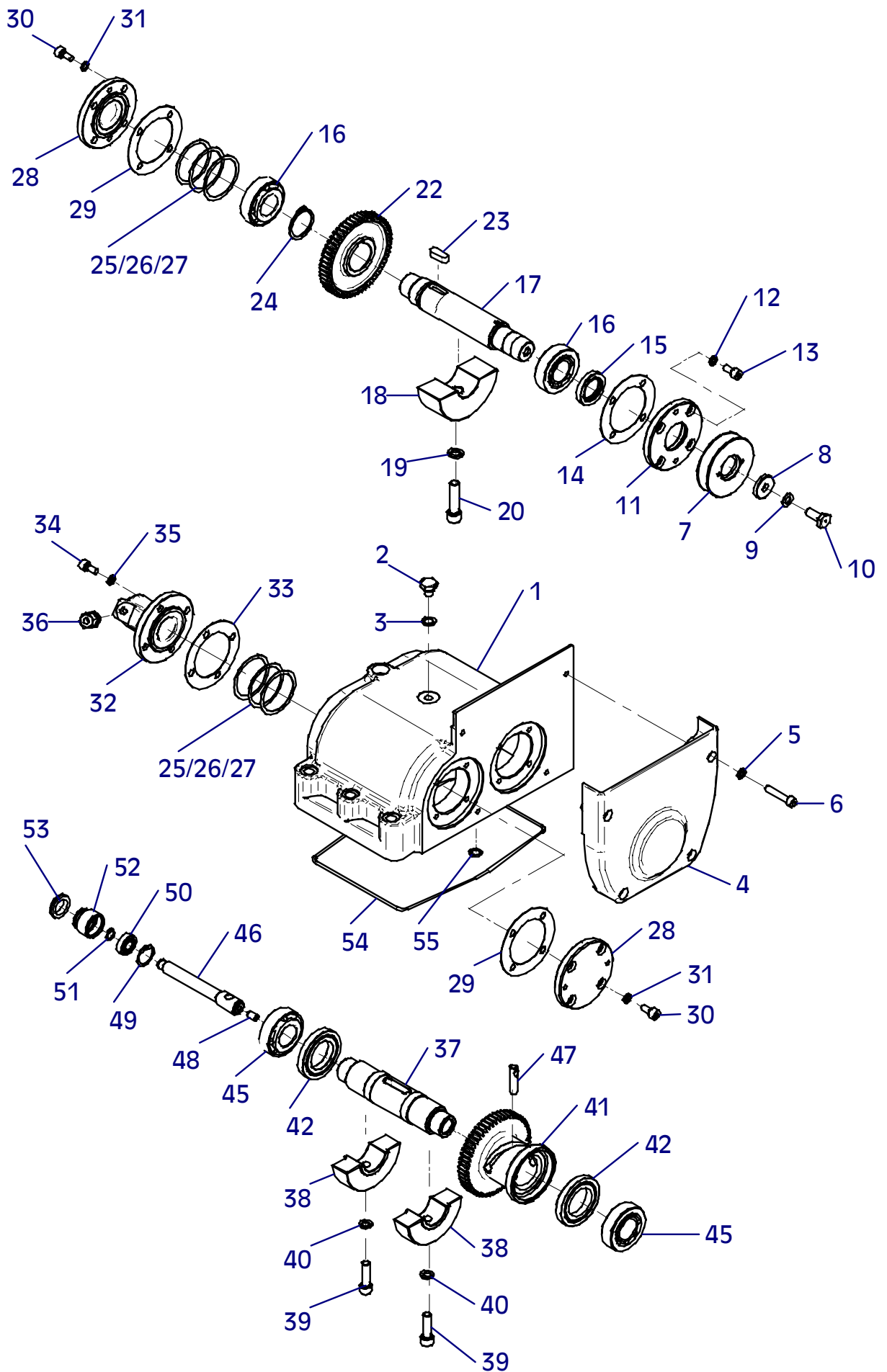

E 3067-0506

E 3068-0907

Position Ref.No. Repère Posizione Posicion	Menge Quantity Quantité Quantita Cantidad	Teile-Nr. Part-No. No. Référence Nr. d'Ordine No. Referenzia	Hinweis Hints Indications Indicazione Indicaciones	Position Ref. No. Repère Posizione Posicion	Menge Quantity Quantité Quantita Cantidad	Teile-Nr. Part-No. No. Référence Nr. d'Ordine No. Referenzia	Hinweis Hints Indications Indicazione Indicaciones
1	1	10022580		30	4	20029011	VSKZ 8
2	1	20005010		31	4	25044081	DIN912-M8x60
3	2	25049016	DIN440-R9	32	1	10022583	
4	1	20029003	VSK 8	33	4	25038015	DIN933-M10x30
5	1	25038007	DIN933-M8x20	34	4	25048003	DIN125-A10,5
6	1	10016959		35	4	20029001	VSK 10
7	1	25049016	DIN440-R9	36	4	25031028	DIN1587-M10
8	1	25038007	DIN933-M8x20	37	1	20026481	
9	1	20029003	VSK 8	38	2	20025019	
10	1	20025564		39	2	25025191	DIN80705-M20x1,5
11	1	20029007	VSK 6	40	1	20007007	
12	1	25038002	DIN933-M6x16	41	1	25048001	DIN125-A6,4
13	1	20007007		42	1	25044003	DIN912-M6x20
14	1	20029007	VSK 6	43	1	25031003	DIN934-M8
15	1	25038002	DIN933-M6x16	44	2	30047498	
16	1	21000356					
17	4	25048003	DIN125-A10,5				
18	4	25038017	DIN933-M10x40				
19	4	25048003	DIN125-A10,5				
20	4	20022003	Tensilock M10				
21	1	10022591					
22	3	25005003	DIN6798-V8,4				
23	3	25047003	DIN7991-M8x16				
24	1	20002094					
25	1	25002094					
26	1	25049016	DIN440-R9				
27	1	20029011	VSKZ 8				
28	1	21000044	DIN912-M8x45-12.9				
29	1	10016883					

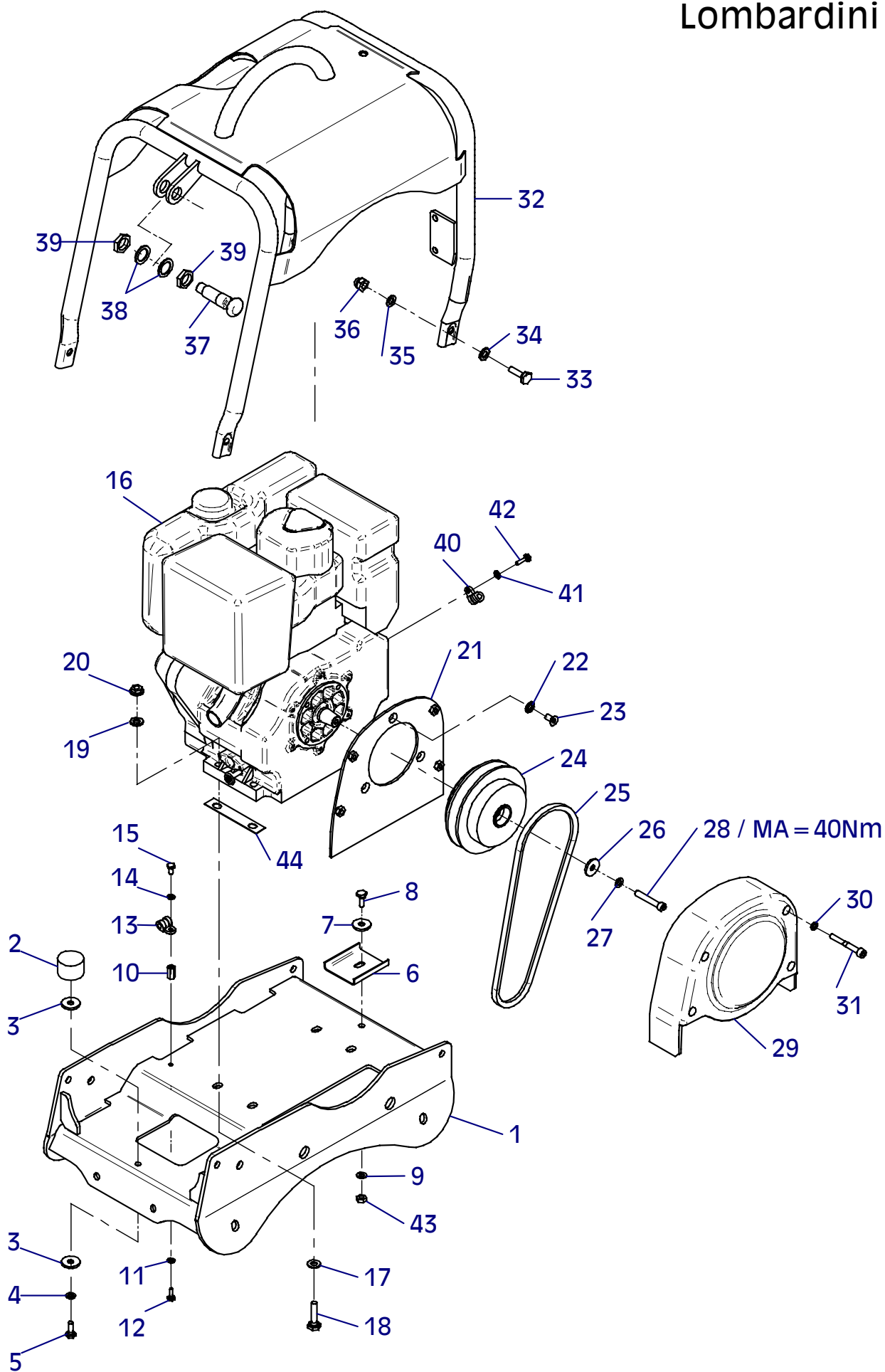

E 3069-0606

Position Ref.No. Repère Posizione Posicion	Menge Quantity Quantité Quantita Cantidad	Teile-Nr. Part-No. No. Référence Nr. d'Ordine No. Referenzia	Hinweis Hints Indications Indicazione Indicaciones	Position Ref. No. Repère Posizione Posicion	Menge Quantity Quantité Quantita Cantidad	Teile-Nr. Part-No. No. Référence Nr. d'Ordine No. Referenzia	Hinweis Hints Indications Indicazione Indicaciones
1	1	20002094					
2	2	20002285					
3	2	20002351					
4	2	20002284					
5	3	21000154					

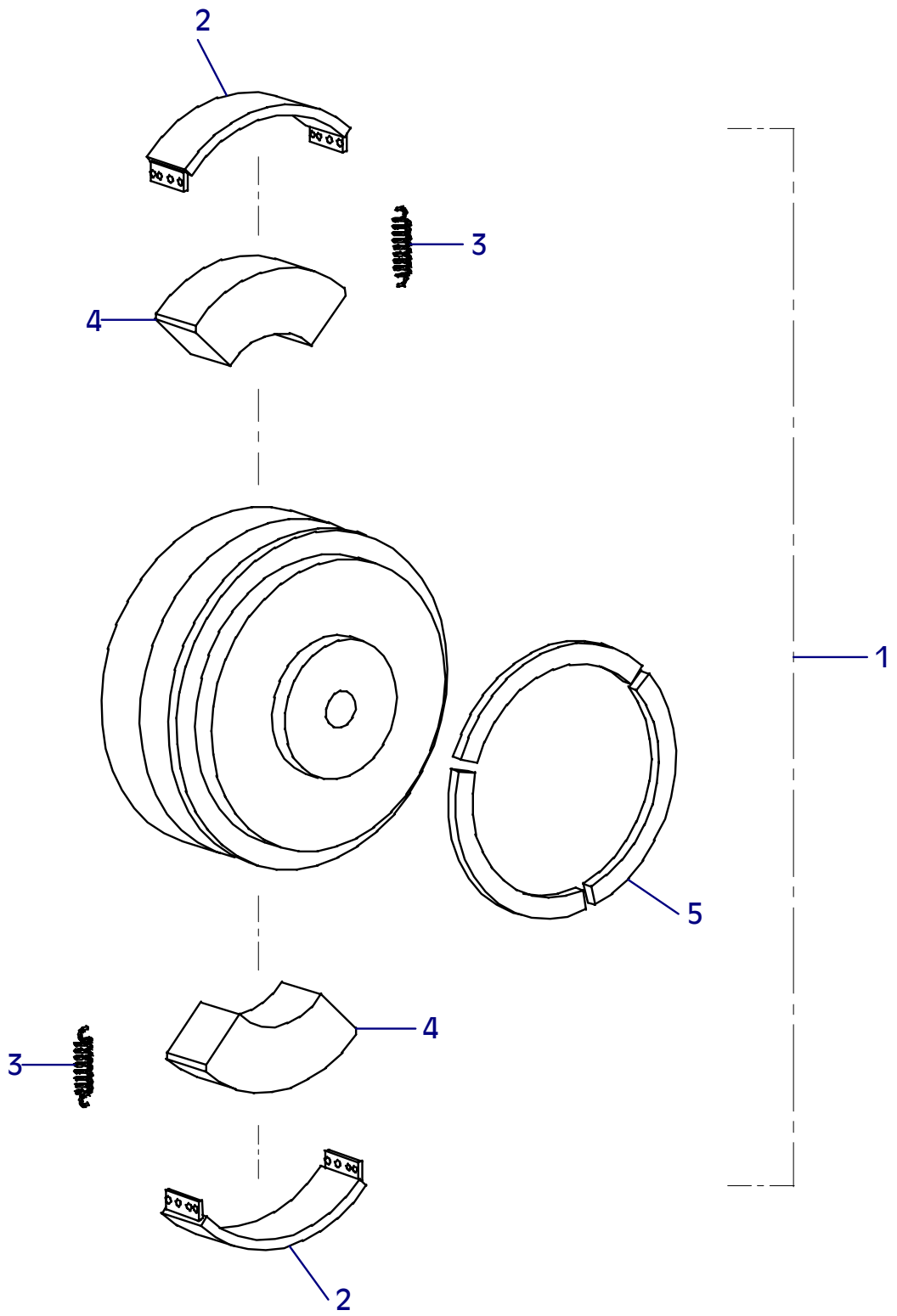

E 3246-0107

Position Ref.No. Repère Posizione Posicion	Menge Quantity Quantité Quantità Cantidad	Teile-Nr. Part-No. No. Référence Nr. d'Ordine No. Referenzia	Hinweis Hints Indications Indicazione Indicaciones	Position Ref. No. Repère Posizione Posicion	Menge Quantity Quantité Quantità Cantidad	Teile-Nr. Part-No. No. Référence Nr. d'Ordine No. Referenzia	Hinweis Hints Indications Indicazione Indicaciones
1	1	10022580		30	1	25038011	DIN933-M8x40
2	1	20005010		31	1	10016883	
3	2	25049016	DIN440-R9	32	4	20029011	VSKZ 8
4	1	20029003	VSK 8	33	4	25044081	DIN912-M8x60
5	1	25038007	DIN933-M8x20	34	1	10022582	
6	1	10016959		35	4	25048003	DIN125-A10,5
7	1	25049016	DIN440-R9	36	4	25038015	DIN933-M10x30
8	1	25038007	DIN933-M8x20	37	4	20029001	VSK 10
9	1	20029003	VSK 8	38	4	25031028	DIN1587-M10
10	1	20025564		39	1	20026481	
11	1	20029007	VSK 6	40	2	20025019	
12	1	25038002	DIN933-M6x16	41	2	25025191	DIN80705-M20x1,5
13	1	20007007		42	2	10017034	
14	1	20029007	VSK 6	43	1	25031003	DIN934-M8
15	1	25038002	DIN933-M6x16	44	1	21000239	
16	1	21000080		45	1	25031002	DIN934-M6
17	1	10016928		46	2	25048001	DIN125-A6,4
18	3	20029012	VSKZ 10	47	1	20029007	VSK 6
19	3	25044013	DIN912-M10x30	48	1	21000235	
20	4	25048002	DIN125-A8,4	49	1	20007007	
21	4	20029024		50	1	25038002	DIN933-M6x16
22	4	25038010	DIN933-M8x35	51	1	25047026	DIN7991-M10x30
23	1	30047446		52	1	25005004	DIN6798-V10,5
24	1	10022593		53	1	20029003	VSK 8
25	4	25005003	DIN6798-V8,4				
26	4	25047017	DIN7991-M8x20				
27	1	21000233					
28	1	21000288					
29	1	25049016	DIN440-R9				

Robin

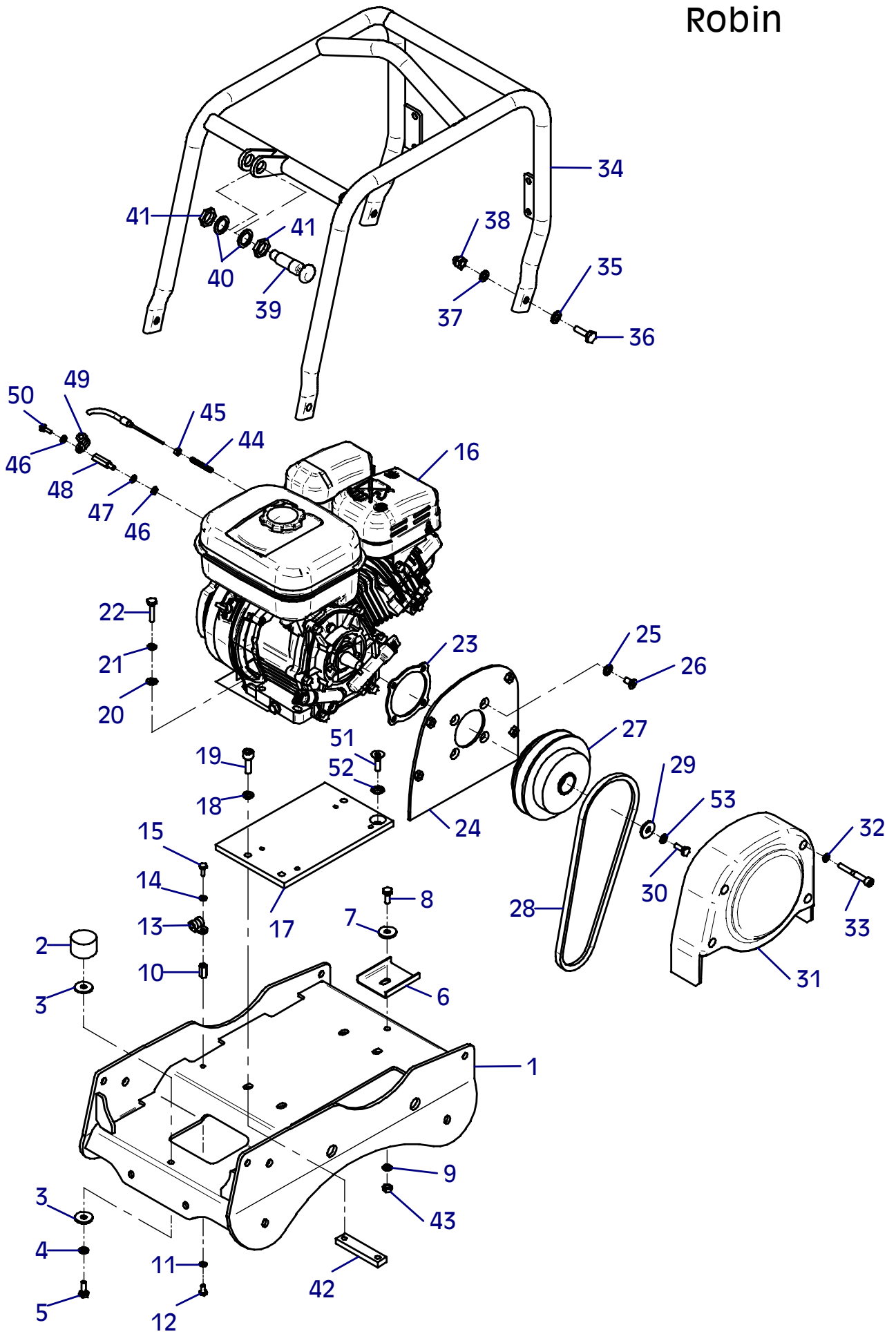

E 3246-0107

E 3247-0107

Position Ref.No. Repère Posizione Posicion	Menge Quantity Quantité Quantita Cantidad	Teile-Nr. Part-No. No. Référence Nr. d'Ordine No. Referenzia	Hinweis Hints Indications Indicazione Indicaciones	Position Ref. No. Repère Posizione Posicion	Menge Quantity Quantité Quantita Cantidad	Teile-Nr. Part-No. No. Référence Nr. d'Ordine No. Referenzia	Hinweis Hints Indications Indicazione Indicaciones
1	1	21000233					
2	2	20002285					
3	2	20002351					
4	2	20002284					
5	3	21000019					

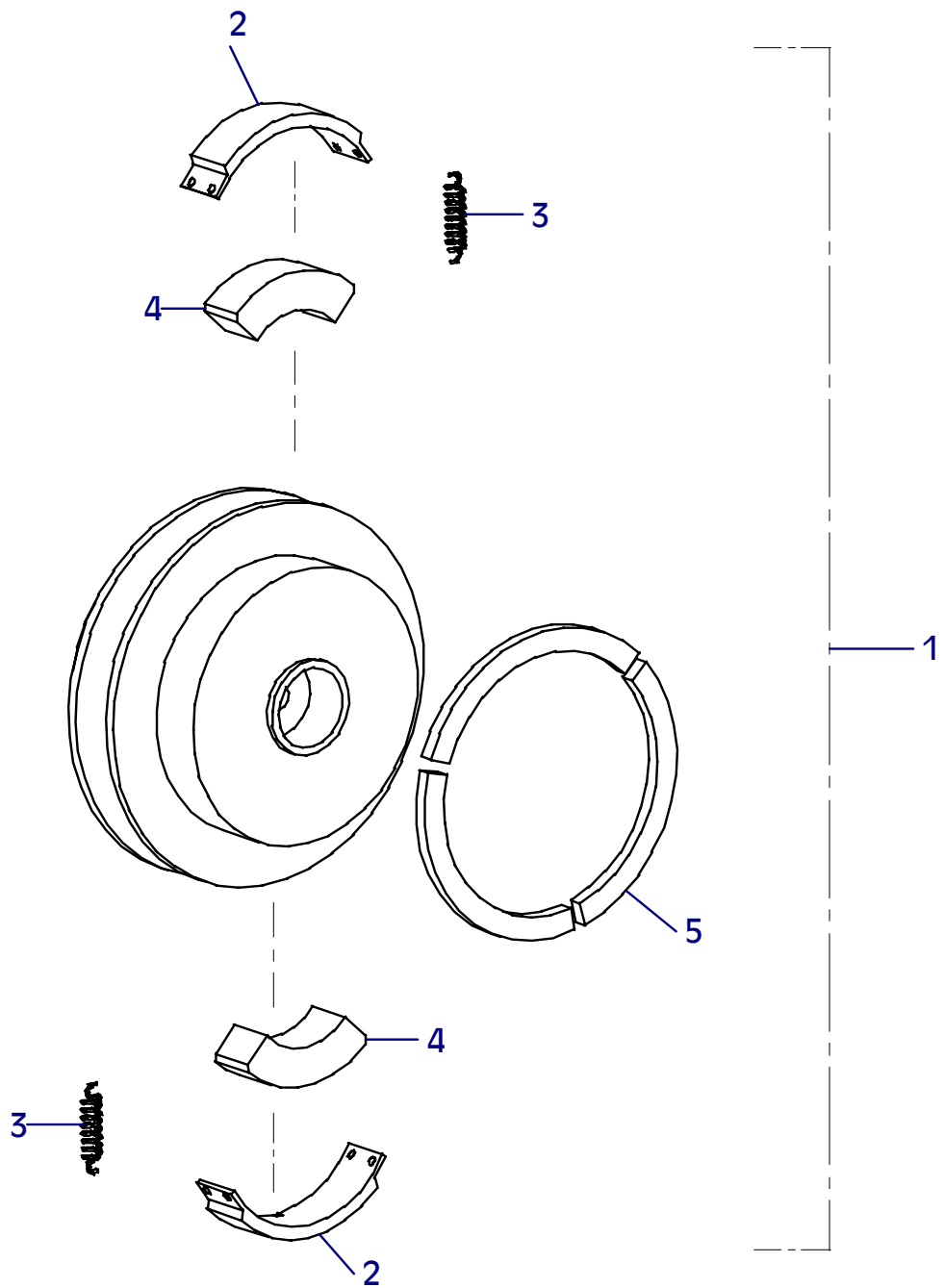

E 3247-0107

E 3072-0105

Position Ref.No. Repère Posizione Posicion	Menge Quantity Quantité Quantita Cantidad	Teile-Nr. Part-No. No. Référence Nr. d'Ordine No. Referenzia	Hinweis Hints Indications Indicazione Indicaciones	Position Ref. No. Repère Posizione Posicion	Menge Quantity Quantité Quantita Cantidad	Teile-Nr. Part-No. No. Référence Nr. d'Ordine No. Referenzia	Hinweis Hints Indications Indicazione Indicaciones
1	1	10022580		30	1	25043005	DIN933-5/16"
2	1	20005010		31	1	10016883	
3	2	25049016	DIN440-R9	32	4	20029011	VSKZ 8
4	1	20029003	VSK 8	33	4	25044081	DIN912-M8x60
5	1	25038007	DIN933-M8x20	34	1	10022582	
6	1	10016959		35	4	25048003	DIN125-A10,5
7	1	25049016	DIN440-R9	36	4	25038015	DIN933-M10x30
8	1	25038007	DIN933-M8x20	37	4	20029001	VSK 10
9	1	20029003	VSK 8	38	4	25031028	DIN1587-M10
10	1	20025564		39	1	20026481	
11	1	20029007	VSK 6	40	2	20025019	
12	1	25038002	DIN933-M6x16	41	2	25025191	DIN80705-M20x1,5
13	1	20007007		42	1	20007007	
14	1	20029007	VSK 6	43	1	25031003	DIN934-M8
15	1	25038002	DIN933-M6x16	44	1	20026383	
16	1	20001208		45	2	10017034	
17	1	10016928		46	1	40001338	
18	3	20029012	VSKZ 10	47	1	25047026	DIN7991-M10x30
19	3	25044013	DIN912-M10x30	48	1	25005004	DIN6798-V10,5
20	4	25049026	DIN7349-8,4	49	1	20026384	
21	4	20029024		50	2	20026389	
22	4	25038010	DIN933-M8x35				
23	1	30047446					
24	1	10022593					
25	4	25005003	DIN6798-V8,4				
26	4	25047062	DIN7991-5/16"-24UNF				
27	1	20002096					
28	1	21000348					
29	1	20029021	SKB 8				

Honda

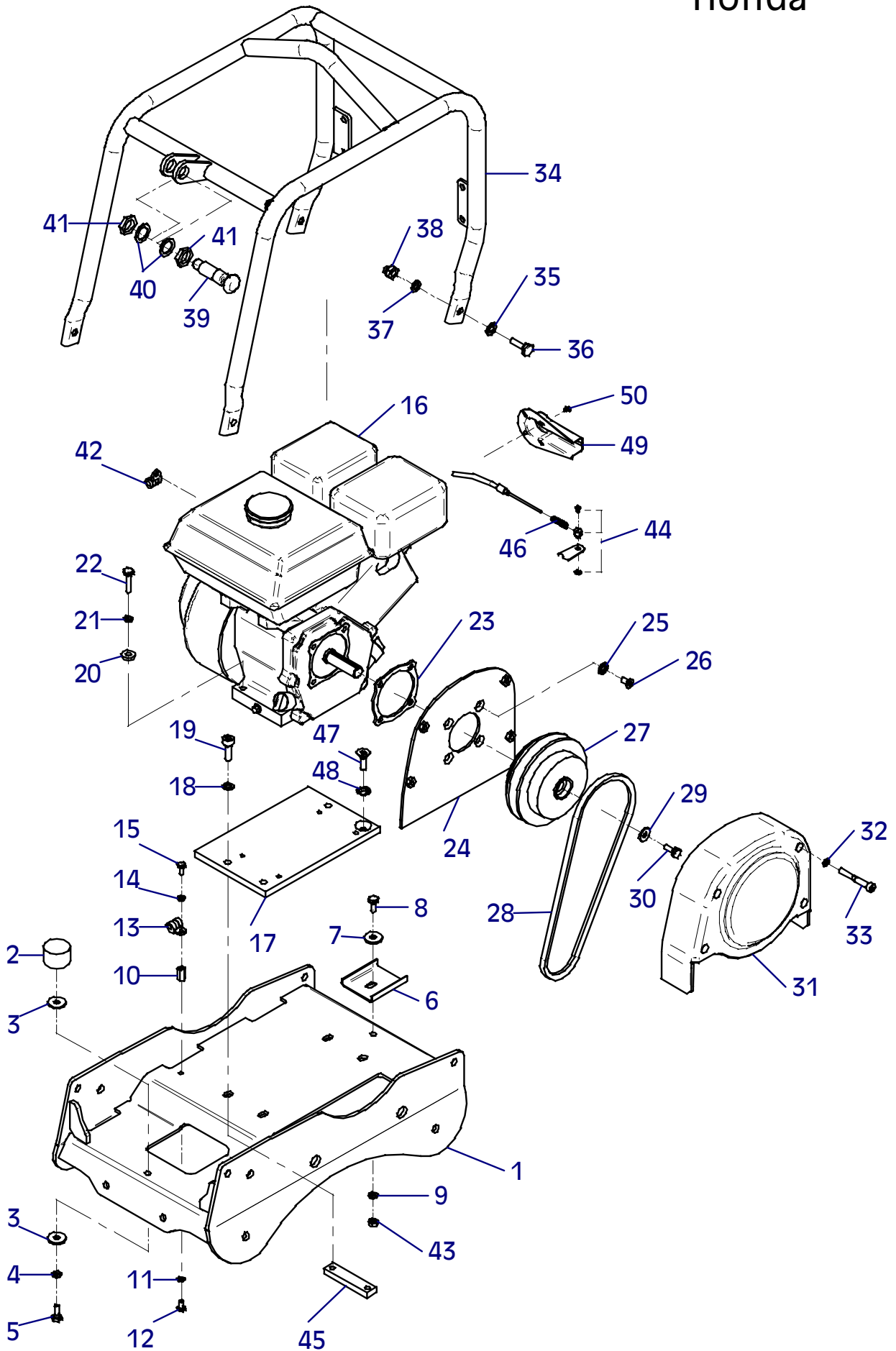

E 3072-0105

E 3073-0606

Position Ref.No. Repère Posizione Posicion	Menge Quantity Quantité Quantita Cantidad	Teile-Nr. Part-No. No. Référence Nr. d'Ordine No. Referenzia	Hinweis Hints Indications Indicazione Indicaciones	Position Ref. No. Repère Posizione Posicion	Menge Quantity Quantité Quantita Cantidad	Teile-Nr. Part-No. No. Référence Nr. d'Ordine No. Referenzia	Hinweis Hints Indications Indicazione Indicaciones
1	1	20002096					
2	2	20002285					
3	2	20002351					
4	2	20002284					
5	3	21000154					

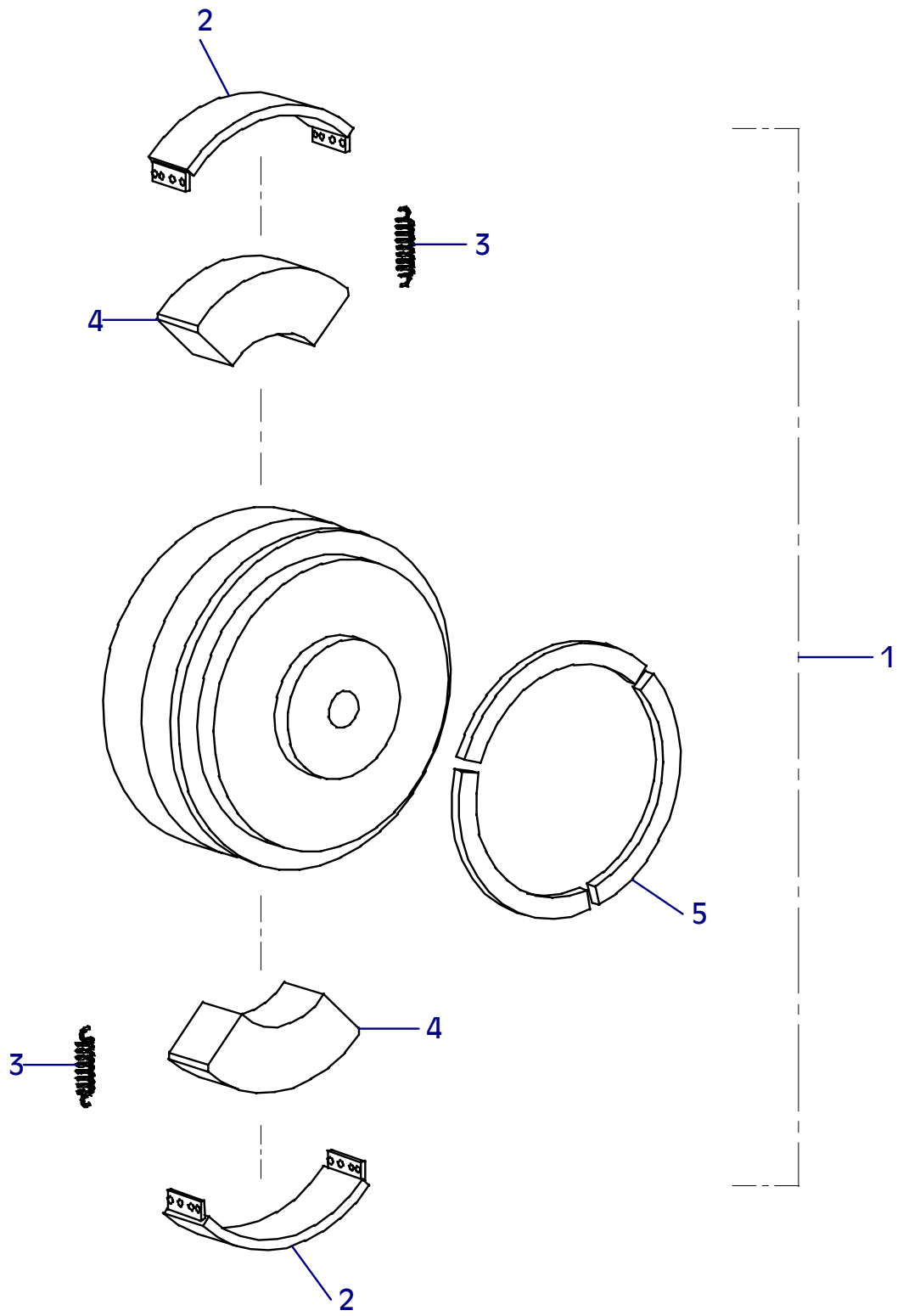

E 3074-0606

Position Ref.No. Repère Posizione Posicion	Menge Quantity Quantité Quantità Cantidad	Teile-Nr. Part-No. No. Référence Nr. d'Ordine No. Referenzia	Hinweis Hints Indications Indicazioni Indicaciones	Position Ref. No. Repère Posizione Posicion	Menge Quantity Quantité Quantità Cantidad	Teile-Nr. Part-No. No. Référence Nr. d'Ordine No. Referenzia	Hinweis Hints Indications Indicazioni Indicaciones
1	1	10016872		40	2	25031003	DIN934-M8
2	1	25008016	DIN7603-14x18x1,5	41	1	25038009	DIN933-M8x30
3	1	25030002	DIN908-M14x1,5	42	1	20029003	VSK 8
4	2	25040033	DIN931-M12x70	45	1	10016875	
5	2	20029004	VSK 12	46	4	25038006	DIN933-M8x16
6	2	25048004	DIN125-A13	47	1	10022588	
7	2	10016877		48	1	25048002	DIN125-A8,4
8	2	20026493		49	1	25038009	DIN933-M8x30
9	2	10016876		50	1	20029003	VSK 8
10	4	20029011	VSKZ 8	51	1	25031013	DIN985-M8
11	4	25044046	DIN912-M8x55	52	2	10016866	
12	2	20026546		53	2	20025443	
13	2	20004061		54	2	10022521	
14	2	20029004	VSK 12	55	2	20029023	SKB 12
15	2	25044053	DIN912-M12x20	56	2	25040020	DIN931-M12x60
16	1	20013298		57	2	20026468	
17	1	10016869		58	1	10022620	
18	1	20013282		59	4	20029031	SKM 8
19	1	10016867		60	1	10022628	
20	1	20013284		61	7	20029031	SKM 8
21	1	20013286		62	7	25033032	ISO7380-M8x16-10.9
22	1	20029024		63	1	10016358	Lombardini/Robin
23	1	25031003	DIN934-M8	63	1	10016938	Honda
24	1	10016870		64	1	20018134	
25	4	20029007	VSK 6	65	2	25048001	DIN125-A6,4
26	4	25038003	DIN933-M6x20	66	2	25033033	ISO7380-M6x30
27	1	20020035		67	2	20022001	Tensilock M6
28	1	20016390		68	1	20018021	
29	1	10016868		69	1	20006416	Lombardini
30	1	20008067		69	1	21000241	Robin/Honda
31	1	20026542		70	1	25044074	DIN912-M6x12
32	1	25008009	DIN7603-30x36x2	71	1	20022001	Tensilock M6
33	1	10017050		72	2	20007007	
34	1	20013296		73	2	25048001	DIN125-A6,4
35	1	25035025	DIN472-I24x1,2	74	2	25033029	ISO7380-M6x16-10.9
36	1	20013297		75	2	20022001	Tensilock M6
37	1	25031003	DIN934-M8	76	1	25028003	DIN915-M8x25
38	1	10017042		77	1	25031003	DIN934-M8
39	2	20018159					

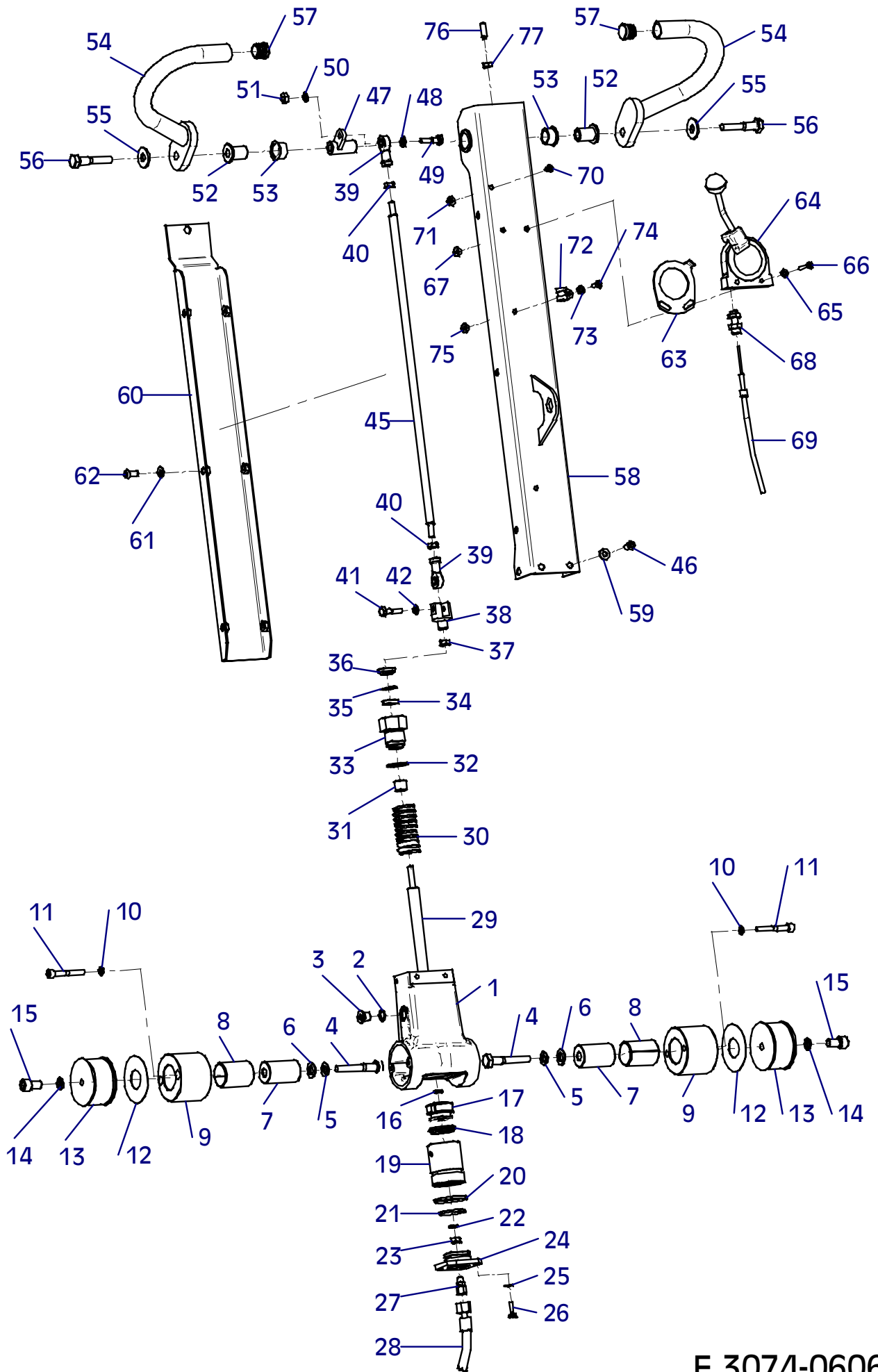

E 3074-0606

E 3075-0303

Position Ref.No. Repère Posizione Posicion	Menge Quantity Quantité Quantita Cantidad	Teile-Nr. Part-No. No. Référence Nr. d'Ordine No. Referenzia	Hinweis Hints Indications Indicazione Indicaciones	Position Ref. No. Repère Posizione Posicion	Menge Quantity Quantité Quantita Cantidad	Teile-Nr. Part-No. No. Référence Nr. d'Ordine No. Referenzia	Hinweis Hints Indications Indicazione Indicaciones
1	1	10022610					
2	2	20025007					
3	4	25048006	DIN125-A21				
4	2	25037011					
5	1	10016239					
6	1	25038060	DIN933-M10x50				
7	1	25031004	DIN934-M10				
8	1	20025508					
9	1	10022609					
10	2	25038014	DIN933-M10x25				
11	2	25048003	DIN125-A10,5				
12	2	20029001	VSK 10				
13	2	25031004	DIN934-M10				

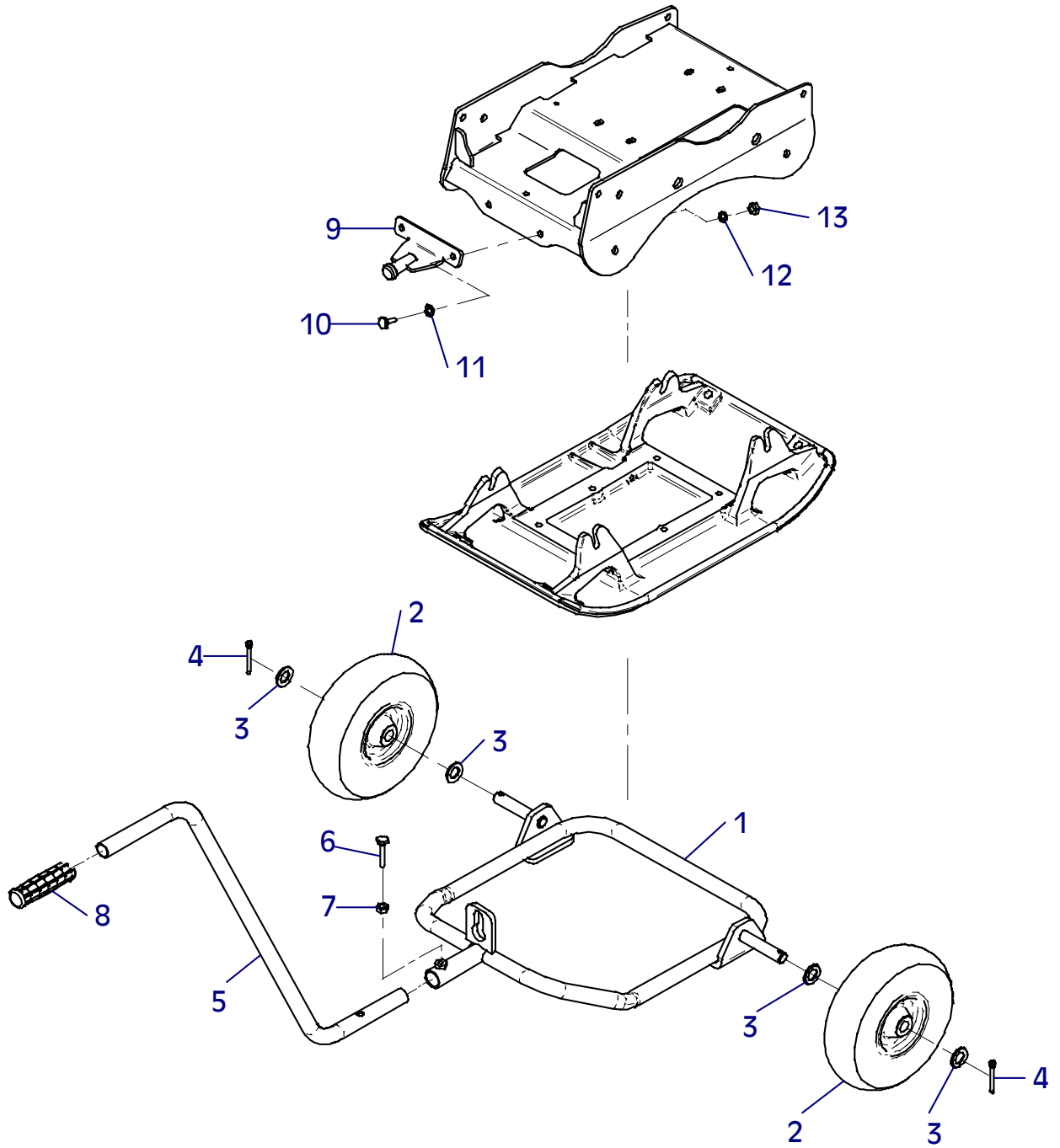

E 3075-0303

E 3076-0303

Position Ref.No. Repère Posizione Posicion	Menge Quantity Quantité Quantita Cantidad	Teile-Nr. Part-No. No. Référence Nr. d'Ordine No. Referenzia	Hinweis Hints Indications Indicazione Indicaciones	Position Ref. No. Repère Posizione Posicion	Menge Quantity Quantité Quantita Cantidad	Teile-Nr. Part-No. No. Référence Nr. d'Ordine No. Referenzia	Hinweis Hints Indications Indicazione Indicaciones
1	1	10017000					
2	2	10017002					
3	4	25040018	DIN931-M12x50				
4	4	25048004	DIN125-A13				
5	4	20029004	VSK 12				
6	4	25031005	DIN934-M12				

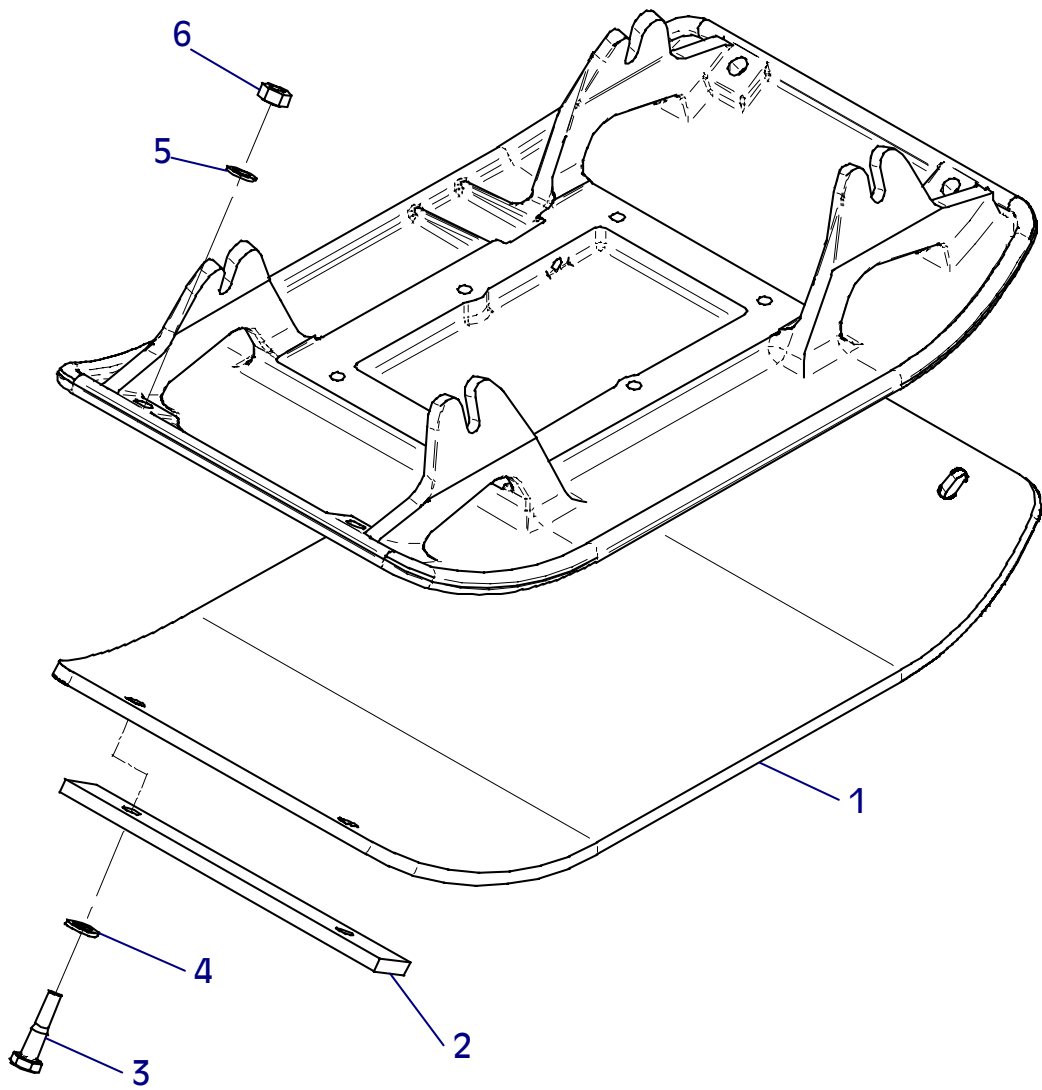

E 3076-0303

E 3124-0105

Position Ref.No. Repère Posizione Posicion	Menge Quantity Quantité Quantita Cantidad	Teile-Nr. Part-No. No. Référence Nr. d'Ordine No. Referenzia	Hinweis Hints Indications Indicazione Indicaciones	Position Ref. No. Repère Posizione Posicion	Menge Quantity Quantité Quantita Cantidad	Teile-Nr. Part-No. No. Référence Nr. d'Ordine No. Referenzia	Hinweis Hints Indications Indicazione Indicaciones
1	1	20026575					
2	1	20025719					
3	1	10022641					
4	4	25038008	DIN933-M8x25				
5	8	25048002	DIN125-A8,4				
6	4	25031003	DIN934-M8				
7	1	10017143					
8	4	25038006	DIN933-M8x16				
9	4	20029021	SKB 8				
10	1	20030018					
11	1	25025143					
12	1	20030012					
13	1	20013292					
14	1	10017142					
15	2	20026480					
16	2	20025775					
17	1	10017351					
18	3	25038007	DIN933-M8x20				
19	1	20025671					
20	1	20029022	SKB 10				
21	1	20025829					

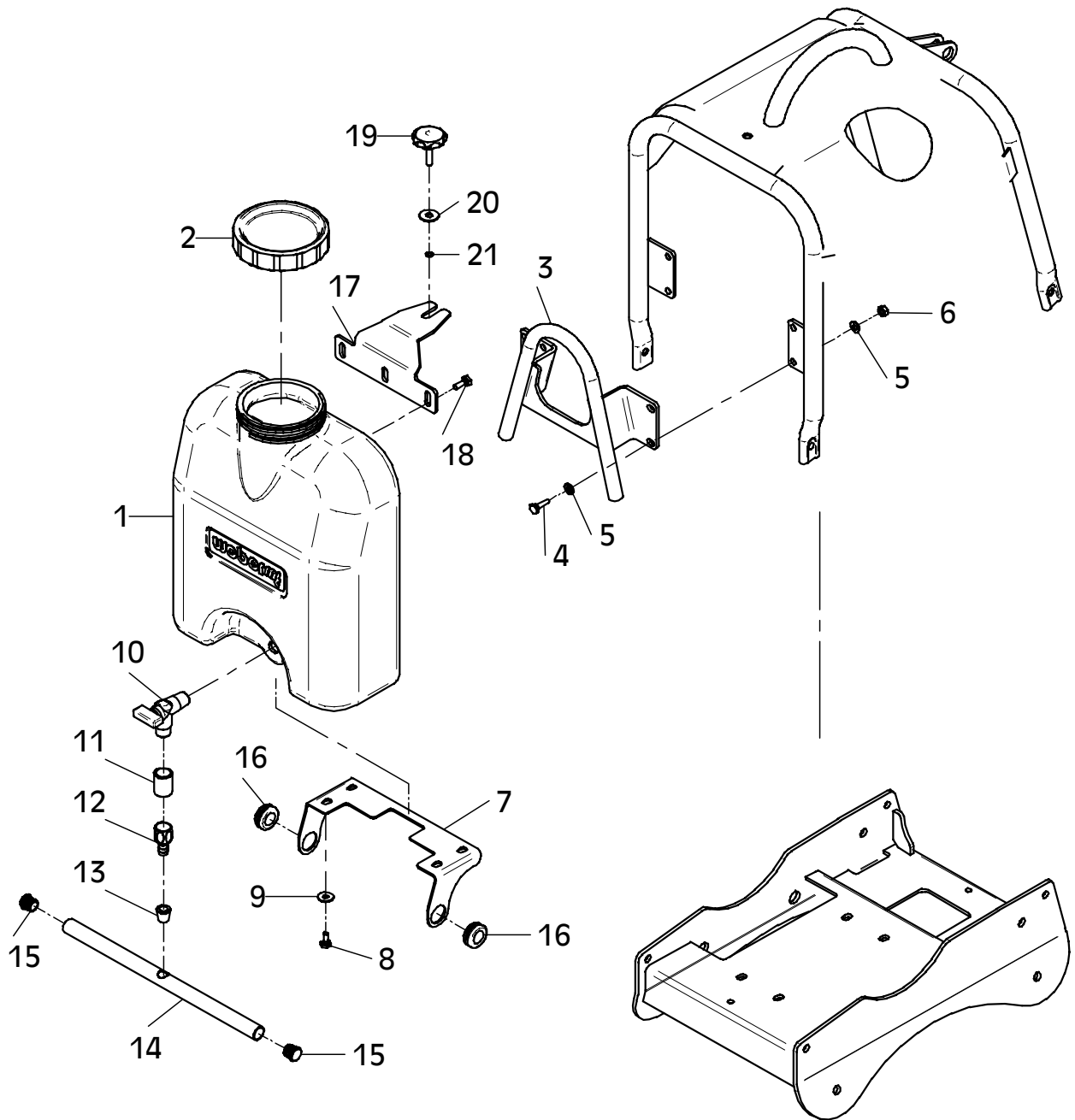

E 3192-0105

Position Ref.No. Repère Posizione Posicion	Menge Quantity Quantité Quantita Cantidad	Teile-Nr. Part-No. No. Référence Nr. d'Ordine No. Referenzia	Hinweis Hints Indications Indicazione Indicaciones	Position Ref. No. Repère Posizione Posicion	Menge Quantity Quantité Quantita Cantidad	Teile-Nr. Part-No. No. Référence Nr. d'Ordine No. Referenzia	Hinweis Hints Indications Indicazione Indicaciones
1	1	20026575		31	2	20029015	VSKZ 6
2	1	20025719					
3	1	10022641					
4	3	25038008	DIN933-M8x25				
5	6	25048002	DIN125-A8,4				
6	3	25031003	DIN934-M8				
7	1	10017143					
8	4	25038006	DIN933-M8x16				
9	4	20029021	SKB 8				
10	1	20030018					
11	1	25025143					
12	1	20030012					
13	1	20013292					
14	1	10017142					
15	2	20026480					
16	2	20025775					
17	1	10022680					
18	2	25038009	DIN933-M8x30				
19	2	25048002	DIN125-A8,4				
20	2	25031003	DIN934-M8				
21	1	10017367					
22	1	10017352					
23	3	25038007	DIN933-M8x20				
24	1	20025671					
25	1	20029022	SKB 10				
26	1	20025829					
27	1	20007230					
28	1	20007231					
29	1	10022679					
30	2	25044123	DIN912-M6x60				

Robin / Honda

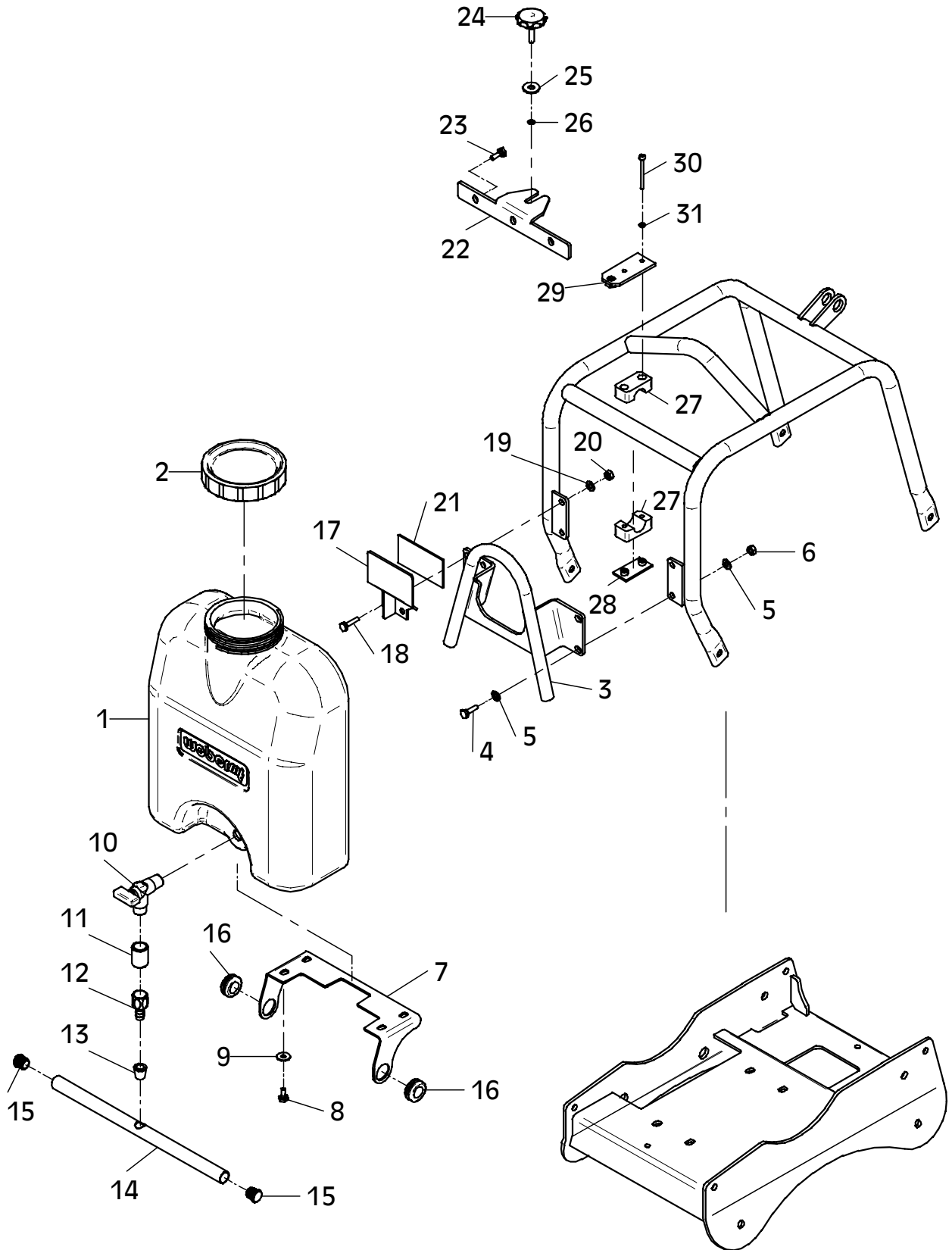

**Wenn Sie Fragen und Anregungen haben, oder sonstige Informationen benötigen,
wenden Sie sich bitte an eine der unten genannten Adressen:**

**For questions and further information refer to one of the
following addresses:**

<p>In Deutschland</p> <p>In Germany</p>	<p>WEBER Maschinenteknik GmbH Postfach 2153 57329 Bad Laasphe – Rückershausen</p> <p>Information / information: E-mail: info@webermt.de</p> <p>Ersatzteile / spare parts: E-mail: parts@webermt.de</p>	<p>Telefon / phone:</p> <p>Telefax / fax:</p> <p>Telefax / fax:</p>	<p>+49 (0) 2754 / 3980 Zentrale / switchboard</p> <p>+49 (0) 2754 / 398101 Zentrale / switchboard</p> <p>+49 (0) 2754 / 398102 Ersatzteile / spare parts direct dial</p>
<p>In Holland</p> <p>In Netherlands</p>	<p>WEBER Maschinenteknik B.V. Graafschap Hornelaan 159 6001 AC Weert</p> <p>E-mail: info@webermt.nl</p>	<p>Telefon / phone:</p> <p>Telefax / fax:</p>	<p>+31 (0) 495 / 530215</p> <p>+31 (0) 495 / 541839</p>
<p>In Frankreich</p> <p>In France</p>	<p>WEBER Technologie S.A.R.L. 26, rue d'Arsonval 69680 Chassieu</p> <p>E-mail: france@webermt.com</p>	<p>Telefon / phone:</p> <p>Telefax / fax:</p>	<p>+33 (0) 472 / 791020</p> <p>+33 (0) 472 / 791021</p>
<p>In Polen</p> <p>In Poland</p>	<p>WEBER Maschinenteknik SP.ZO.O. ul. Grodziska 7 05-830 Stara Wies / Nadarzyn</p> <p>E-mail: info@webermt.com.pl</p>	<p>Telefon / phone:</p> <p>Telefax / fax:</p>	<p>+48 (0) 22 / 7397080 +48 (0) 22 / 7397081</p> <p>+48 (0) 22 / 7397082</p>
<p>In USA, Kanada</p> <p>In USA, Canada</p>	<p>WEBER Machine (USA), Inc. 40 Johnson Ave 112 Bangor, ME 04401 USA</p> <p>E-mail: usa@webermt.com</p>	<p>Telefon / phone:</p> <p>Telefax / fax:</p>	<p>+1 (0) 207 / 9474990</p> <p>+1 (0) 207 / 9475452</p>
<p>In Südamerika</p> <p>In South America</p>	<p>WEBER Maschinenteknik do Brasil Ltda. Rua Sete de Setembro, 275 93332-470 Novo Hamburgo, RS Brasil</p> <p>E-mail: webermt@webermt.com.br</p>	<p>Telefon / phone:</p> <p>Telefax / fax:</p>	<p>+55 (0) 51 / 5873044</p> <p>+55 (0) 51 / 5872271</p>

<http://www.webermt.com>

