



ERSATZTEILLISTE

SPARE PARTS LIST

**LISTE DES PIECES
DE RECHANGE**

LISTINO RICAMBI

LISTA DE RECAMBIOS

**WYKAZ CZESCI
ZAMIENNYCH**



CR 2

0115601-0115606

Ab Masch.-Nr. 9002205



Weber Maschinenteknik GmbH

Postfach 2153, 57329 Bad Laasphe-Rückershausen

Telefon 02754 / 398-0

Telefax (02754) 398-101 (Zentrale) u. 398-102 (Ersatzteile)

EG - KONFORMITÄTSERKLÄRUNG

EC DECLARATION OF CONFORMITY/ DECLARATION DE CONFORMITE CE
DICHIARAZIONE CE DI CONFORMITA / DECLARACION CE DE CONFORMIDAD
EG-VERKLARING VAN OVEREENSTEMMING / EF-OVERENSSTEMMELSESERKAERING
DECLARACAO CE DE CONFORMIDADE / EG-FÖRSÄKRAN OM ÖVERENSSTÄMMELSE
DEKLARACJA ZGODNOŚCI

im Sinne der EG-Maschinenrichtlinie 98/37/EG
und der EG Richtlinie 2000/14/EG – Geräuschemissionen

- I **Hersteller/** Make / Marque / Marca / Marca / Producent / Merk / Marca /
Tillverkare / Producent **Weber Maschinentechnik GmbH**
Im Boden 5-8,10
57334 Bad Laasphe
- II **Art /** Category / Catégorie / Categoria Tipo / Kategori /
Soort / Categoria / kategori / Typ **Vibrationsplatte**
- III **Typ /** Type / Type / Tipo / Codice / Type / Type / Tipo / Typ /
CR 2
- IV **Nennleistung /** Nominal-performance / La puissance nominale / Prestazione nominale /
Potencia nominal / Nominaal vermogen / Nominel ydelse / Potência nominal / Nominell
effect / Moc **P = 3,5 kW**
- V **gemessener Schalleistungspegel /** measured sound power level / niveau de
puissance acoustique mesure / livello di potenza sonora rilevato / nivel de potencia
acústica medido / gemeten geluidsvermogensniveau / målt lydeffektniveau / Nivel de
potência sonora midido / uppmätt ljudeffektnivå / Mierzony poziom dźwięku **LWA = 106 dB (A)**
- VI **garantierter Schalleistungspegel /** guaranteed sound power level / niveau de
puissance acoustique garanti / livello di potenza sonora garantito / nivel de potencia
acustica garantizado / gewaarborgd geluidsvermogensniveau / garanteret lydeffektniveau /
Nivel sonoro garantido / garanterad ljudeffektnivå / Natężenie hałasu **LWA = 108 dB (A)**
- VII **beteiligte Zertifizierungsstelle /** notified body involved / de l'organisme notifié/
dell'organismo notificato che l'ha effettuata / dirección del organismo notificado que haya
intervenido / betrokken aangemelde instantie / pågældende bemyndigede organ /
organismo notificado involucrado / berörda anmälda organets namn / Jednostka
certyfikująca **RWTÜV**
Postfach 103161
D-45032 Essen
- VIII **Konformitäts-Bewertungsverfahren /** Conformity assessment procedure followed /
la procédure appliquée pour l'évaluation de la conformité et / procedura di valutazione
della conformità / procedimiento de evaluación de la conformidad / gevolgde
overeenstemmingsbeoordelingsprocedure / den fulgte
overensstemmelsesvurderingsprocedure / procedimento de avaliação de conformidade
/ Vilket förfarande för bedömning av överensstämmelse / Przebieg kontroli **interne Fertigungskontrolle**
nach Anhang VI
EG Richtlinie 2000/14/EG

ist in Übereinstimmung mit folgenden Richtlinien hergestellt worden / has been produced in accordance with
following standards / est produit conforme aux dispositions des directives europeenes ci-apres / ha sido fabricado en conformidad
con las siguientes normas / é stato fabbricato in conformità alle sequenti norme / er blevet fremstillet i overensstemmelse med
følgende retningslinier / in overeenstemming met de volgende voorschriften gefabriceerd is / é fabricado conforme as seguintes
normas / har tillverkats i överensstämmelse med följande riktlinjer / Zgodność z obowiązującymi przepisami

98/37/EG Maschinenrichtlinie des europäischen Parlamentes und des Rates vom 22. Juni 1998
2000/14/EG EG-Richtlinie Geräuschemissionen vom 8. Mai 2000
2005/88/EG EG-Richtlinie vom 14. Dez. 2005 zur Änderung der Richtlinie 2000/14/EG
EN 500 Teil 1 Bewegliche Straßenbaumaschinen – Sicherheit
Gemeinsame Anforderungen
EN 500 Teil 4 Bewegliche Straßenbaumaschinen – Sicherheit
Besondere Anforderungen an Verdichtungsmaschinen

Bescheinigung bitte sorgfältig aufbewahren / File certificate carefully / Conserver certificat soigneusement / Conservar
certificado cuidadosamente / Pregasi conservare accuratamente certificato / Beviset bedes opbevares omhyggeligt / Verklaring
a.u.b. zorgvuldig bevar / Conservar o certificado com cuidado / Beviset skall om sorgsfullt bevaras // Deklarację zgodności
proszę zachować

Bad Laasphe – Rückershausen, den **02.01.2009**

W. Weber, Geschäftsführer

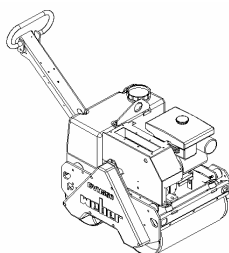

weberm

WEBER Maschinentechnik GmbH
Im Boden 5-8, 10 – D-57334 Bad Laasphe
Postfach 2153 – D-57329 Bad Laasphe
Telefon: 02754/398-0 – Fax 02754/398-101
E-mail: Verkauf@webermt.de
Internet: <http://www.webermt.de>

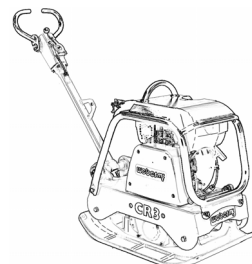

EG - KONFORMITÄTSERKLÄRUNG

EC DECLARATION OF CONFORMITY/ DECLARATION DE CONFORMITE CE
DICHIARAZIONE CE DI CONFORMITA / DECLARACION CE DE CONFORMIDAD
EG-VERKLARING VAN OVEREENSTEMMING / EF-OVERENSSTEMMELSESERKAERING
DECLARACAO CE DE CONFORMIDADE / EG-FÖRSÄKRAN OM ÖVERENSSTÄMMELSE
DEKLARACJA ZGODNOŚCI

im Sinne der EG-Maschinenrichtlinie 98/37/EG
und der EG Richtlinie 2000/14/EG – Geräuschemissionen

- | | | |
|------|---|--|
| I | Hersteller/ Make / Marque / Marca / Marca / Producent / Merk / Marca / Tillverkare / Producent | Weber Maschinentechnik GmbH Im Boden 5-8,10 57334 Bad Laasphe |
| II | Art / Category / Catégorie / Categoria Tipo / Kategori / Soort / Categoria / kategori / Typ | Vibrationsplatte |
| III | Typ / Type / Type / Tipo / Codice / Type / Type / Tipo / Typ / | CR 2 R |
| IV | Nennleistung / Nominal-performance / La puissance nominale / Prestazione nominale / Potencia nominal / Nominaal vermogen / Nomineel ydelse / Potência nominal / Nominell effect / Moc | P = 4,2 kW |
| V | gemessener Schalleistungspegel / measured sound power level / niveau de puissance acoustique mesure / livello di potenza sonora rilevato / nivel de potencia acústica medido / gemeten geluidsvermogensniveau / målt lydeffektniveau / Nivel de potência sonora midido / uppmätt ljudeffektnivå / Mierzony poziom dźwięku | LWA = 106 dB (A) |
| VI | garantierter Schalleistungspegel / guaranteed sound power level / niveau de puissance acoustique garanti / livello di potenza sonora garantito / nivel de potencia acustica garantizado / gewaarborgd geluidsvermogensniveau / garanteret lydeffektniveau / Nivel sonoro garantido / garanterad ljudeffektniva / Natężenie hałasu | LWA = 108 dB (A) |
| VII | beteiligte Zertifizierungsstelle / notified body involved / de l'organisme notifié/ dell'organismo notificato che l'ha effettuata / dirección del organismo notificado que haya intervenido / betrokken aangemelde instantie / pågældende bemyndigede organ / organismo notificado involucrado / berörda anmälda organets namn / Jednostka certyfikująca | RWTÜV Postfach 103161 D-45032 Essen |
| VIII | Konformitäts-Bewertungsverfahren / Conformity assessment procedure followed / la procédure appliquée pour l'évaluation de la conformité et / procedura di valutazione della conformità / procedimiento de evaluación de la conformidad / gevolgde overeenstemmingsbeoordelingsprocedure / den fulgte overensstemmelssesvurderingsprocedure / procedimento de avaliacao de conformidade / Vilket förfarande för bedömning av överensstämmelse / Przebieg kontroli | interne Fertigungskontrolle nach Anhang VI EG Richtlinie 2000/14/EG |

ist in Übereinstimmung mit folgenden Richtlinien hergestellt worden /has been produced in accordance with following standards / est produit conforme aux dispositions des directives europeenes ci-apres / ha sido fabricado en conformidad con las siguientes normas / é stato fabbricato in conformità alle sequenti norme / er blevet fremstillet i overensstemmelse med følgende retningslinier / in overensstemming met de volgende voorschriften gefabriceerd is / é fabricado conforme as seguintes normas / har tillverkats i överensstämmelse med följande riktlinjer / Zgodność z obowiązującymi przepisami

| | |
|----------------------|---|
| 98/37/EG | Maschinenrichtlinie des europäischen Parlamentes und des Rates vom 22. Juni 1998 |
| 2000/14/EG | EG-Richtlinie Geräuschemissionen vom 8. Mai 2000 |
| 2005/88/EG | EG-Richtlinie vom 14. Dez. 2005 zur Änderung der Richtlinie 2000/14/EG |
| EN 500 Teil 1 | Bewegliche Straßenbaumaschinen – Sicherheit |
| EN 500 Teil 4 | Gemeinsame Anforderungen Bewegliche Straßenbaumaschinen – Sicherheit Besondere Anforderungen an Verdichtungsmaschinen |

Bescheinigung bitte sorgfältig aufbewahren / File certificate carefully / Conserver certificat soigneusement / Conservar certificado cuidadosamente / Pregasi conservare accuratamente certificato / Beviset bedes opbevares omhyggeligt / Verklaring a.u.b. zorgvuldig bevare / Conservar o certificado com cuidado / Beviset skall om sorgsfullt bevaras // Deklarację zgodności proszę zachować

Bad Laasphe – Rückershausen, den **02.01.2009**

W. Weber, Geschäftsführer

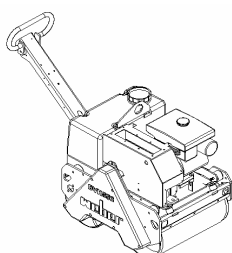

webermt

WEBER Maschinentechnik GmbH
Im Boden 5-8, 10 – D-57334 Bad Laasphe
Postfach 2153 – D-57329 Bad Laasphe
Telefon: 02754/398-0 – Fax 02754/398-101
E-mail: Verkauf@webermt.de
Internet: <http://www.webermt.de>



EG - KONFORMITÄTSERKLÄRUNG

EC DECLARATION OF CONFORMITY/ DECLARATION DE CONFORMITE CE
DICHIARAZIONE CE DI CONFORMITA / DECLARACION CE DE CONFORMIDAD
EG-VERKLARING VAN OVEREENSTEMMING / EF-OVERENSSTEMMELSESERKAERING
DECLARACAO CE DE CONFORMIDADE / EG-FÖRSÄKRAN OM ÖVERENSSTÄMMELSE
DEKLARACJA ZGODNOŚCI

im Sinne der EG-Maschinenrichtlinie 98/37/EG
und der EG Richtlinie 2000/14/EG – Geräuschemissionen

- I **Hersteller/** Make / Marque / Marca / Marca / Producent / Merk / Marca /
Tillverkare / Producent **Weber Maschinentechnik GmbH**
Im Boden 5-8,10
57334 Bad Laasphe
- II **Art /** Category / Catégorie / Categoria Tipo / Kategori /
Soort / Categoria / kategori / Typ **Vibrationsplatte**
- III **Typ /** Type / Type / Tipo / Codice / Type / Type / Tipo / Typ /
CR 2 Hd
- IV **Nennleistung /** Nominal-performance / La puissance nominale / Prestazione nominale /
Potencia nominal / Nominaal vermogen / Nominel ydelse / Potência nominal / Nominell
effect / Moc **P = 4,0 kW**
- V **gemessener Schalleistungspegel /** measured sound power level / niveau de
puissance acoustique mesure / livello di potenza sonora rilevato / nivel de potencia
acústica medido / gemeten geluidsvermogensniveau / målt lydeffektniveau / Nivel de
potência sonora midido / uppmätt ljudeffektnivå / Mierzony poziom dźwięku
LWA = 107 dB (A)
- VI **garantierter Schalleistungspegel /** guaranteed sound power level / niveau de
puissance acoustique garanti / livello di potenza sonora garantito / nivel de potencia
acustica garantizado / gewaarborgd geluidsvermogensniveau / garanteret lydeffektniveau /
Nivel sonoro garantido / garanterad ljudeffektnivå / Natężenie hałas
LWA = 108 dB (A)
- VII **beteiligte Zertifizierungsstelle /** notified body involved / de l'organisme notifié/
dell'organismo notificato che l'ha effettuata / dirección del organismo notificado que haya
intervenido / betrokken aangemelde instantie / pågældende bemyndigede organ /
organismo notificado involucrado / berörda anmälda organets namn / Jednostka
certyfikująca
RWTÜV
Postfach 103161
D-45032 Essen
- VIII **Konformitäts-Bewertungsverfahren /** Conformity assessment procedure followed /
la procédure appliquée pour l'évaluation de la conformité et / procedura di valutazione
della conformità / procedimiento de evaluación de la conformidad / gevolgde
overeenstemmingsbeoordelingsprocedure / den fulgte
overensstemmelsesvurderingsprocedure / procedimento de avaliação de conformidade
/ Vilket förfarande för bedömning av överensstämmelse / Przebieg kontroli
interne Fertigungskontrolle
nach Anhang VI
EG Richtlinie 2000/14/EG

ist in Übereinstimmung mit folgenden Richtlinien hergestellt worden /has been produced in accordance with
following standards / est produit conforme aux dispositions des directives europeenes ci-apres / ha sido fabricado en conformidad
con las siguientes normas / é stato fabbricato in conformità alle sequenti norme / er blevet fremstillet i overensstemmelse med
følgende retningslinier / in overeenstemming met de volgende voorschriften gefabriceerd is / é fabricado conforme as seguintes
normas / har tillverkats i överensstämmelse med följande riktlinjer / Zgodność z obowiązującymi przepisami

98/37/EG Maschinenrichtlinie des europäischen Parlamentes und des Rates vom 22. Juni 1998
2000/14/EG EG-Richtlinie Geräuschemissionen vom 8. Mai 2000
2005/88/EG EG-Richtlinie vom 14. Dez. 2005 zur Änderung der Richtlinie 2000/14/EG
EN 500 Teil 1 Bewegliche Straßenbaumaschinen – Sicherheit
Gemeinsame Anforderungen
EN 500 Teil 4 Bewegliche Straßenbaumaschinen – Sicherheit
Besondere Anforderungen an Verdichtungsmaschinen

Bescheinigung bitte sorgfältig aufbewahren / File certificate carefully / Conserver certificat soigneusement / Conservar
certificado cuidadosamente / Pregasi conservare accuratamente certificato / Beviset bedes opbevares omhyggeligt / Verklaring
a.u.b. zorgvuldig bevaar / Conservar o certificado com cuidado / Beviset skall om sorgsfullt bevaras // Deklarację zgodności
proszę zachować

Bad Laasphe – Rückershausen, den **02.01.2009**

W. Weber, Geschäftsführer

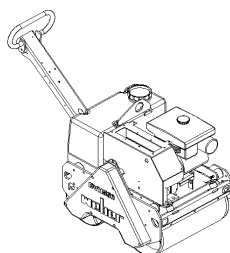

WEBER Maschinentechnik GmbH
Im Boden 5-8, 10 – D-57334 Bad Laasphe
Postfach 2153 – D-57329 Bad Laasphe
Telefon: 02754/398-0 – Fax 02754/398-101
E-mail: Verkauf@webermt.de
Internet: <http://www.webermt.de>

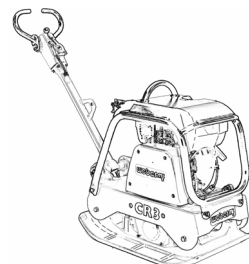

BITTE, NOTIEREN SIE SERIENNUMMER UND MOTORNUMMER IHRER MASCHINE:

PLEASE WRITE DOWN SERIALNUMBERS OF MACHINE AND ENGINE:

NOTEZ SVP LE NUMERO DE SERIE ET LE NUMERO DU MOTEUR DE VOTRE MACHINE:

SI PREGA DI ANNOTARE SEMPRE I NUMERI DI SERIE SIA DELLA VS. MACCHINA CHE DEL MOTORE:

MAQUINA: ROGAMOS ANOTEN EL NUMERO DE SERIE Y NUMERO DE MOTOR DE SU MAQUINA:

MASCHINE
MACHINE
MACCHINA
MAQUINA

| |
|-------------|
| # # # |
|-------------|

MOTOR
ENGINE
MOTEUR
MOTORE

| |
|-------------|
| # # # |
|-------------|

ZUR VERMEIDUNG VON FEHLLIEFERUNGEN UND VERZÖGERUNGEN SIND BEI DER BESTELLUNG VON ERSATZTEILEN FOLGENDE ANGABEN UNBEDINGT ERFORDERLICH:

- MASCHINENTYP
- SERIENNUMMER DER MASCHINE
- SERIENNUMMER DES MOTORS (BEI MOTORTEILEN)
- TEILENUMMER
- BESTELLMENGE

TO AVOID ERRORS IN DELIVERY PLEASE STATE THESE PARTICULARS WHEN ORDERING:

- TYPE OF MACHINE
- SERIAL NO. OF MACHINE
- SERIAL NO. OF ENGINE (ON ENGINE PARTS)
- PART-NO.
- QUANTITY REQUIRED

AFIN D'EVITER DES ERREURS DE COMMANDE ET DES RETARDS DE LIVRAISON IL EST NECESSAIRE D'INDIQUER LES CARACTERISTIQUES SUIVANTES:

- TYPE DE MACHINE
- LE NUMERO DE SERIE DE LA MACHINE
- LE NUMERO DE SERIE DU MOTEUR
- LE NUMERO D'IDENTITE DE LA PIECE
- LA QUANTITE SOUHAITEE

ONDE EVITARE DISGUIDI E RITARDI NELLE CONSEGNE DIE RICAMBI SI PREGA DI INDICARE SEMPRE:

- TIPO DELLA MACCHINA
- NUMERO DI SERIE DELLA MACCHINA
- NUMERO DI SERIE DEL MOTORE (SE SI RICHIEDONO PEZZI DEL MOTORE)
- NUMERO D'ORDINE DIE SINGOLI RICAMBI
- QUANTITA

A FI DE EVITAR ERRORES DE ENTREGA, ROGAMOS INDIQUEN LOS SIGUIENTES DATOS CUANDO PASE PEDIDOS DE RECAMBIO:

- MODELO DE MAQUINA
- NO. DE SERIE DE LA MAQUINA
- NO. DE SERIE DEL MOTOR (EN PIEZAS PARA MOTOR)
- REFERENCIA DEL RECAMBIO
- CANTIDAD PEDIDA

E 3121-0204

| Position Ref.No. Repère Posizione Posicion | Menge Quantity Quantité Quantita Cantidad | Teile-Nr. Part-No. No. Référence Nr. d'Ordine No. Referenzia | Hinweis Hints Indications Indicazione Indicaciones | Position Ref. No. Repère Posizione Posicion | Menge Quantity Quantité Quantita Cantidad | Teile-Nr. Part-No. No. Référence Nr. d'Ordine No. Referenzia | Hinweis Hints Indications Indicazione Indicaciones |
|--|---|--|--|---|---|--|--|
| 1 | 1 | 10017087 | | | | | |
| 2 | 1 | 25030001 | DIN908-M10x1 | | | | |
| 3 | 4 | 20004014 | | | | | |
| 4 | 4 | 20029023 | SKB 12 | | | | |
| 5 | 4 | 25031005 | DIN934-M12 | | | | |
| 6 | 1 | 10001464 | | | | | |
| 7 | 6 | 21000049 | DIN912-M12x70-12.9 | | | | |
| 8 | 2 | 25045041 | DIN912-M12x140-12.9 | | | | |
| 9 | 8 | 20029026 | | | | | |
| 10 | 4 | 20029004 | VSK 12 | | | | |
| 11 | 4 | 25038042 | DIN933-M12x16 | | | | |
| 12 | 4 | 10017190 | | | | | |

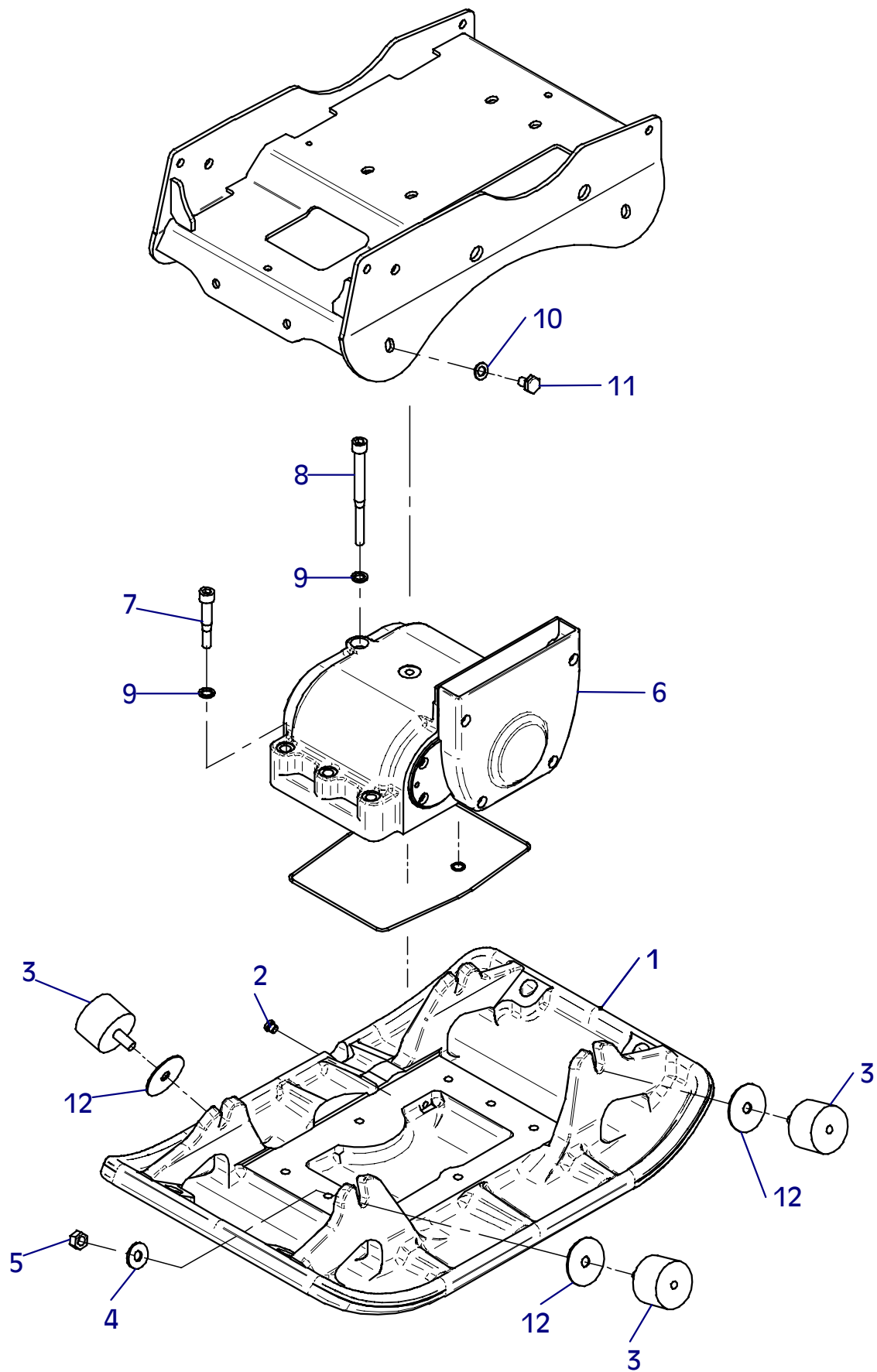

E 3121-0204

E 3122-0204

| Position Ref.No. Repère Posizione Posicion | Menge Quantity Quantité Quantita Cantidad | Teile-Nr. Part-No. No. Référence Nr. d'Ordine No. Referenzia | Hinweis Hints Indications Indicazione Indicaciones | Position Ref. No. Repère Posizione Posicion | Menge Quantity Quantité Quantita Cantidad | Teile-Nr. Part-No. No. Référence Nr. d'Ordine No. Referenzia | Hinweis Hints Indications Indicazione Indicaciones |
|--|---|--|--|---|---|--|--|
| 1 | 1 | 10016782 | | 31 | 8 | 20029011 | VSKZ 8 |
| 2 | 1 | 25038042 | DIN933-M12x16 | 32 | 1 | 10017149 | |
| 3 | 1 | 25008011 | DIN7603-12x18x1,5 | 33 | 1 | 20013295 | |
| 4 | 1 | 10016783 | | 34 | 4 | 25044100 | DIN912-M8x16 |
| 5 | 4 | 20029011 | VSKZ 8 | 35 | 4 | 20029011 | VSKZ 8 |
| 6 | 4 | 25044008 | DIN912-M8x40 | 36 | 1 | 20020035 | |
| 7 | 1 | 10016791 | | 37 | 1 | 10017152 | |
| 8 | 1 | 10016071 | | 38 | 2 | 10017153 | |
| 9 | 1 | 20029001 | VSK 10 | 39 | 2 | 25045028 | DIN912-M10x35-10.9 |
| 10 | 1 | 10007370 | | 40 | 2 | 20029025 | |
| 11 | 1 | 10017148 | | 41 | 1 | 10016795 | |
| 12 | 4 | 20029011 | VSKZ 8 | 42 | 2 | 25001022 | |
| 13 | 4 | 25046015 | DIN7984-M8x16 | 43 | 1 | 20008095 | |
| 14 | 1 | 20013295 | | 44 | 1 | 25048003 | DIN125-A10,5 |
| 15 | 1 | 25017047 | | 45 | 2 | 25001156 | |
| 16 | 2 | 25001156 | | 46 | 1 | 10017154 | |
| 17 | 1 | 10017150 | | 47 | 1 | 10008320 | |
| 18 | 1 | 10017151 | | 48 | 1 | 25027004 | DIN914-M8x16 |
| 19 | 1 | 20029026 | | 49 | 1 | 25035026 | DIN472-I28x1,2 |
| 20 | 1 | 25045037 | DIN912-M12x45-10.9 | 50 | 1 | 25001513 | |
| 21 | 1 | 20013301 | | 51 | 1 | 25034002 | DIN471-A12 |
| 22 | 1 | 10016790 | | 52 | 1 | 10016066 | |
| 23 | 1 | 25015046 | | 53 | 1 | 20013270 | |
| 24 | 1 | 25034020 | DIN471-A38x1,75 | 54 | 1 | 25035011 | DIN472-I20 |
| 25 | 0 | 20025561 | | 55 | 2 | 20013103 | |
| 26 | 0 | 20025215 | | | | | |
| 27 | 0 | 20025163 | | | | | |
| 28 | 2 | 10017147 | | | | | |
| 29 | 2 | 20013295 | | | | | |
| 30 | 8 | 25044100 | DIN912-M8x16 | | | | |

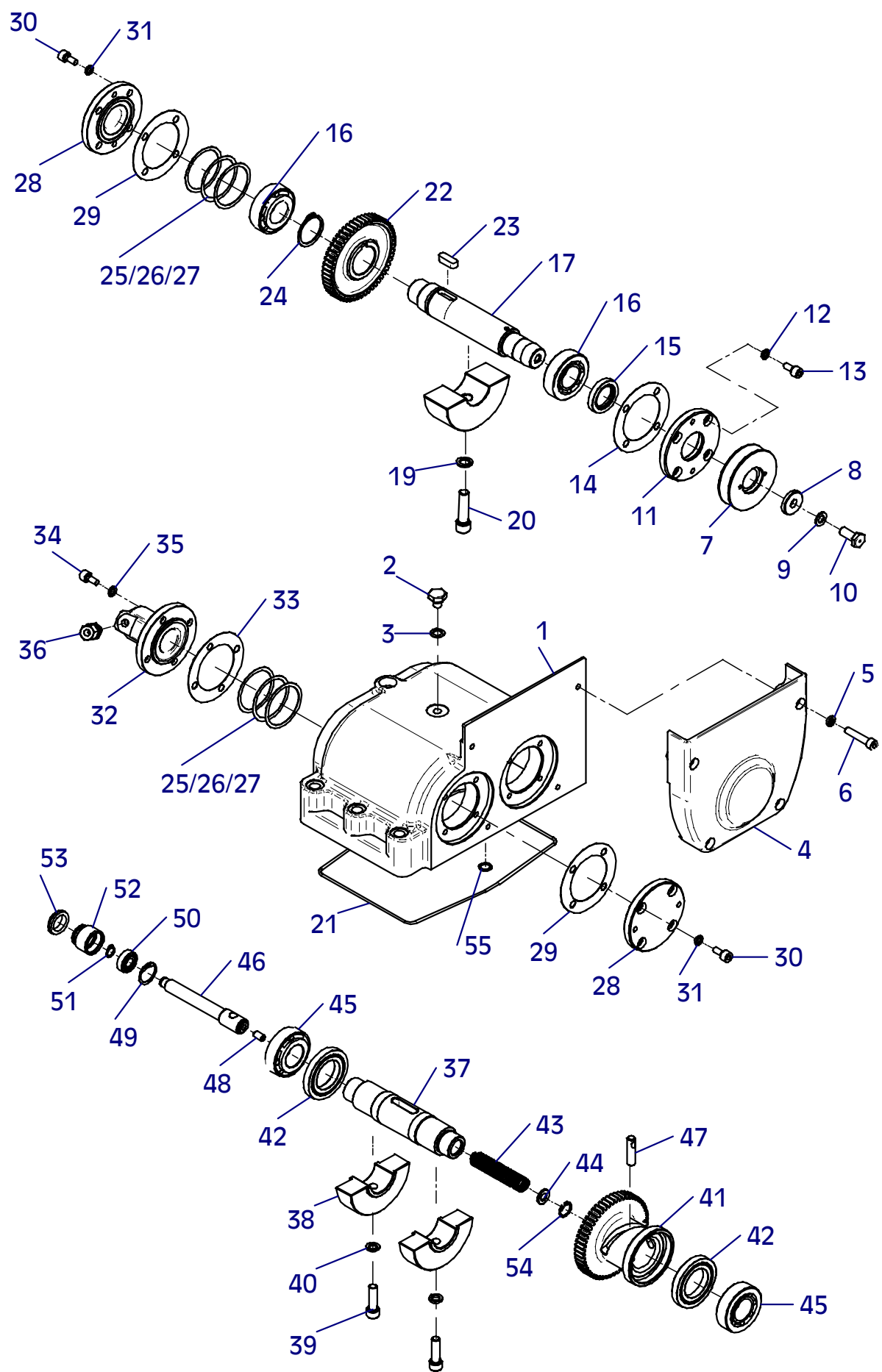

E 3122-0204

E 3235-0409

| Position Ref.No. Repère Posizione Posicion | Menge Quantity Quantité Quantita Cantidad | Teile-Nr. Part-No. No. Référence Nr. d'Ordine No. Referenzia | Hinweis Hints Indications Indicazione Indicaciones | Position Ref. No. Repère Posizione Posicion | Menge Quantity Quantité Quantita Cantidad | Teile-Nr. Part-No. No. Référence Nr. d'Ordine No. Referenzia | Hinweis Hints Indications Indicazione Indicaciones |
|--|---|--|--|---|---|--|--|
| 1 | 1 | 10022580 | | 30 | 4 | 20029011 | VSKZ 8 |
| 2 | 1 | 20005010 | | 31 | 4 | 25044081 | DIN912-M8x60 |
| 3 | 2 | 25049016 | DIN440-R9 | 32 | 1 | 10022583 | |
| 4 | 1 | 20029003 | VSK 8 | 33 | 4 | 25038015 | DIN933-M10x30 |
| 5 | 1 | 25038007 | DIN933-M8x20 | 34 | 4 | 25048003 | DIN125-A10,5 |
| 6 | 1 | 10016959 | | 35 | 4 | 20029001 | VSK 10 |
| 7 | 1 | 25049016 | DIN440-R9 | 36 | 4 | 25031028 | DIN1587-M10 |
| 8 | 1 | 25038007 | DIN933-M8x20 | 37 | 1 | 20026481 | |
| 9 | 1 | 20029003 | VSK 8 | 38 | 2 | 20025019 | |
| 10 | 1 | 20025564 | | 39 | 2 | 25025191 | DIN80705-M20x1,5 |
| 11 | 1 | 20029007 | VSK 6 | 40 | 1 | 20007007 | |
| 12 | 1 | 25038002 | DIN933-M6x16 | 41 | 1 | 25048001 | DIN125-A6,4 |
| 13 | 1 | 20007007 | | 42 | 1 | 25044003 | DIN912-M6x20 |
| 14 | 1 | 20029007 | VSK 6 | 43 | 1 | 25031003 | DIN934-M8 |
| 15 | 1 | 25038002 | DIN933-M6x16 | 44 | 2 | 30047498 | |
| 16 | 1 | 21000356 | | 45 | 1 | 25048001 | DIN125-A6,4 |
| 17 | 4 | 25048003 | DIN125-A10,5 | 46 | 2 | 25031002 | DIN934-M6 |
| 18 | 4 | 25038017 | DIN933-M10x40 | 47 | 2 | 25048001 | DIN125-A6,4 |
| 19 | 4 | 25048003 | DIN125-A10,5 | | | | |
| 20 | 4 | 20022003 | Tensilock M10 | | | | |
| 21 | 1 | 10022591 | | | | | |
| 22 | 3 | 25005003 | DIN6798-V8,4 | | | | |
| 23 | 3 | 25047003 | DIN7991-M8x16 | | | | |
| 24 | 1 | 20002094 | | | | | |
| 25 | 1 | 25002052 | | | | | |
| 26 | 1 | 25049016 | DIN440-R9 | | | | |
| 27 | 1 | 20029011 | VSKZ 8 | | | | |
| 28 | 1 | 21000044 | DIN912-M8x45-12.9 | | | | |
| 29 | 1 | 10016883 | | | | | |

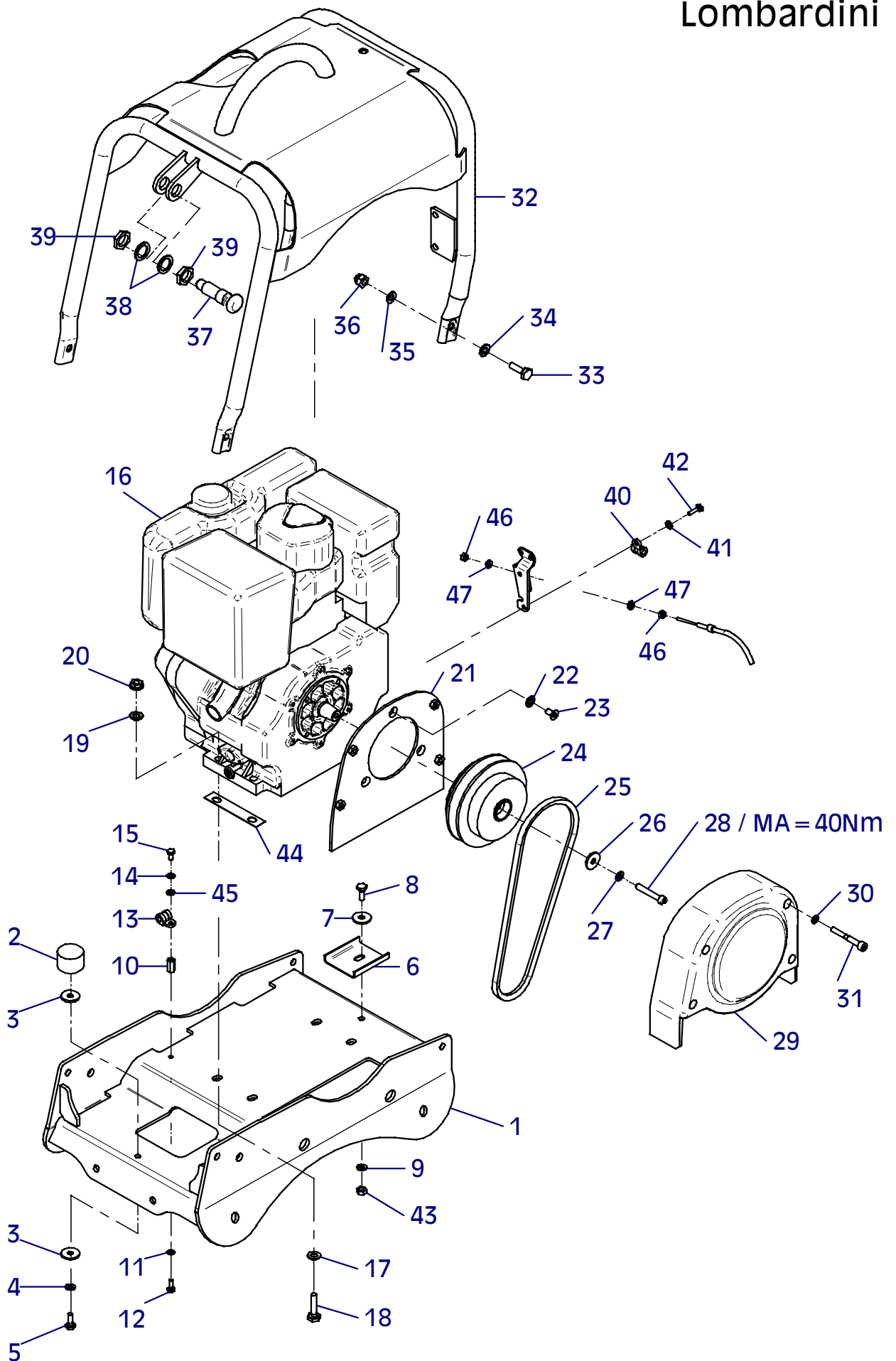

E 3069-0606

| Position Ref.No. Repère Posizione Posicion | Menge Quantity Quantité Quantita Cantidad | Teile-Nr. Part-No. No. Référence Nr. d'Ordine No. Referenzia | Hinweis Hints Indications Indicazione Indicaciones | Position Ref. No. Repère Posizione Posicion | Menge Quantity Quantité Quantita Cantidad | Teile-Nr. Part-No. No. Référence Nr. d'Ordine No. Referenzia | Hinweis Hints Indications Indicazione Indicaciones |
|--|---|--|--|---|---|--|--|
| 1 | 1 | 20002094 | | | | | |
| 2 | 2 | 20002285 | | | | | |
| 3 | 2 | 20002351 | | | | | |
| 4 | 2 | 20002284 | | | | | |
| 5 | 3 | 21000154 | | | | | |

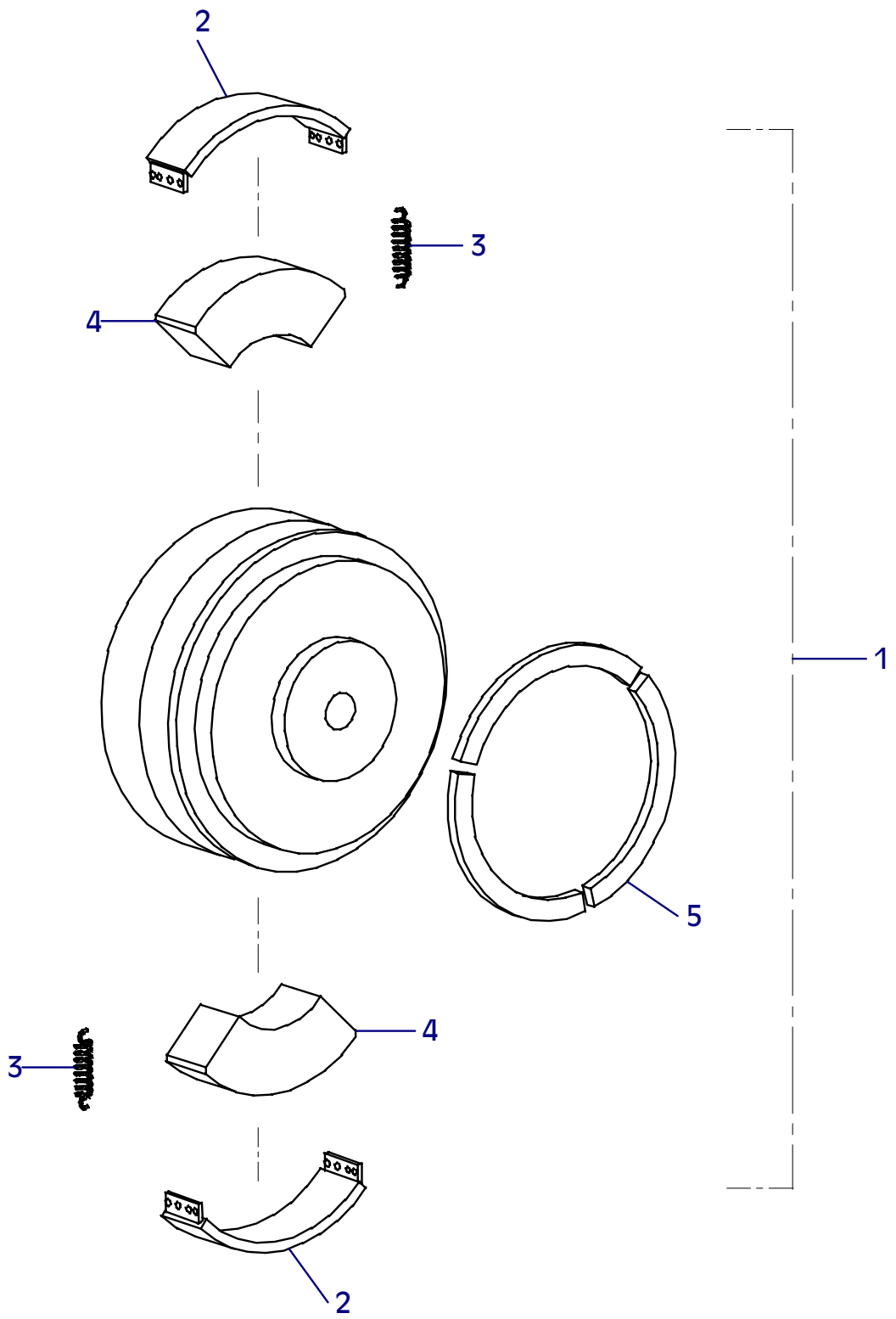

E 3245-0107

| Position Ref.No. Repère Posizione Posicion | Menge Quantity Quantité Quantità Cantidad | Teile-Nr. Part-No. No. Référence Nr. d'Ordine No. Referenzia | Hinweis Hints Indications Indicazione Indicaciones | Position Ref. No. Repère Posizione Posicion | Menge Quantity Quantité Quantità Cantidad | Teile-Nr. Part-No. No. Référence Nr. d'Ordine No. Referenzia | Hinweis Hints Indications Indicazione Indicaciones |
|--|---|--|--|---|---|--|--|
| 1 | 1 | 10022580 | | 30 | 1 | 25038011 | DIN933-M8x40 |
| 2 | 1 | 20005010 | | 31 | 1 | 10016883 | |
| 3 | 2 | 25049016 | DIN440-R9 | 32 | 4 | 20029011 | VSKZ 8 |
| 4 | 1 | 20029003 | VSK 8 | 33 | 4 | 25044081 | DIN912-M8x60 |
| 5 | 1 | 25038007 | DIN933-M8x20 | 34 | 1 | 10022582 | |
| 6 | 1 | 10016959 | | 35 | 4 | 25048003 | DIN125-A10,5 |
| 7 | 1 | 25049016 | DIN440-R9 | 36 | 4 | 25038015 | DIN933-M10x30 |
| 8 | 1 | 25038007 | DIN933-M8x20 | 37 | 4 | 20029001 | VSK 10 |
| 9 | 1 | 20029003 | VSK 8 | 38 | 4 | 25031028 | DIN1587-M10 |
| 10 | 1 | 20025564 | | 39 | 1 | 20026481 | |
| 11 | 1 | 20029007 | VSK 6 | 40 | 2 | 20025019 | |
| 12 | 1 | 25038002 | DIN933-M6x16 | 41 | 2 | 25025191 | DIN80705-M20x1,5 |
| 13 | 1 | 20007007 | | 42 | 2 | 10017034 | |
| 14 | 1 | 20029007 | VSK 6 | 43 | 1 | 25031003 | DIN934-M8 |
| 15 | 1 | 25038002 | DIN933-M6x16 | 44 | 1 | 21000239 | |
| 16 | 1 | 21000080 | | 45 | 1 | 25031002 | DIN934-M6 |
| 17 | 1 | 10016928 | | 46 | 2 | 25048001 | DIN125-A6,4 |
| 18 | 3 | 20029012 | VSKZ 10 | 47 | 1 | 20029007 | VSK 6 |
| 19 | 3 | 25044013 | DIN912-M10x30 | 48 | 1 | 21000235 | |
| 20 | 4 | 25048002 | DIN125-A8,4 | 49 | 1 | 20007007 | |
| 21 | 4 | 20029024 | | 50 | 1 | 25038002 | DIN933-M6x16 |
| 22 | 4 | 25038010 | DIN933-M8x35 | 51 | 1 | 25047026 | DIN7991-M10x30 |
| 23 | 1 | 30047446 | | 52 | 1 | 25005004 | DIN6798-V10,5 |
| 24 | 1 | 10022593 | | 53 | 1 | 20029003 | VSK 8 |
| 25 | 4 | 25005003 | DIN6798-V8,4 | 54 | 1 | 25048001 | DIN125-A6,4 |
| 26 | 4 | 25047017 | DIN7991-M8x20 | | | | |
| 27 | 1 | 21000233 | | | | | |
| 28 | 1 | 25002083 | | | | | |
| 29 | 1 | 25049016 | DIN440-R9 | | | | |

Robin

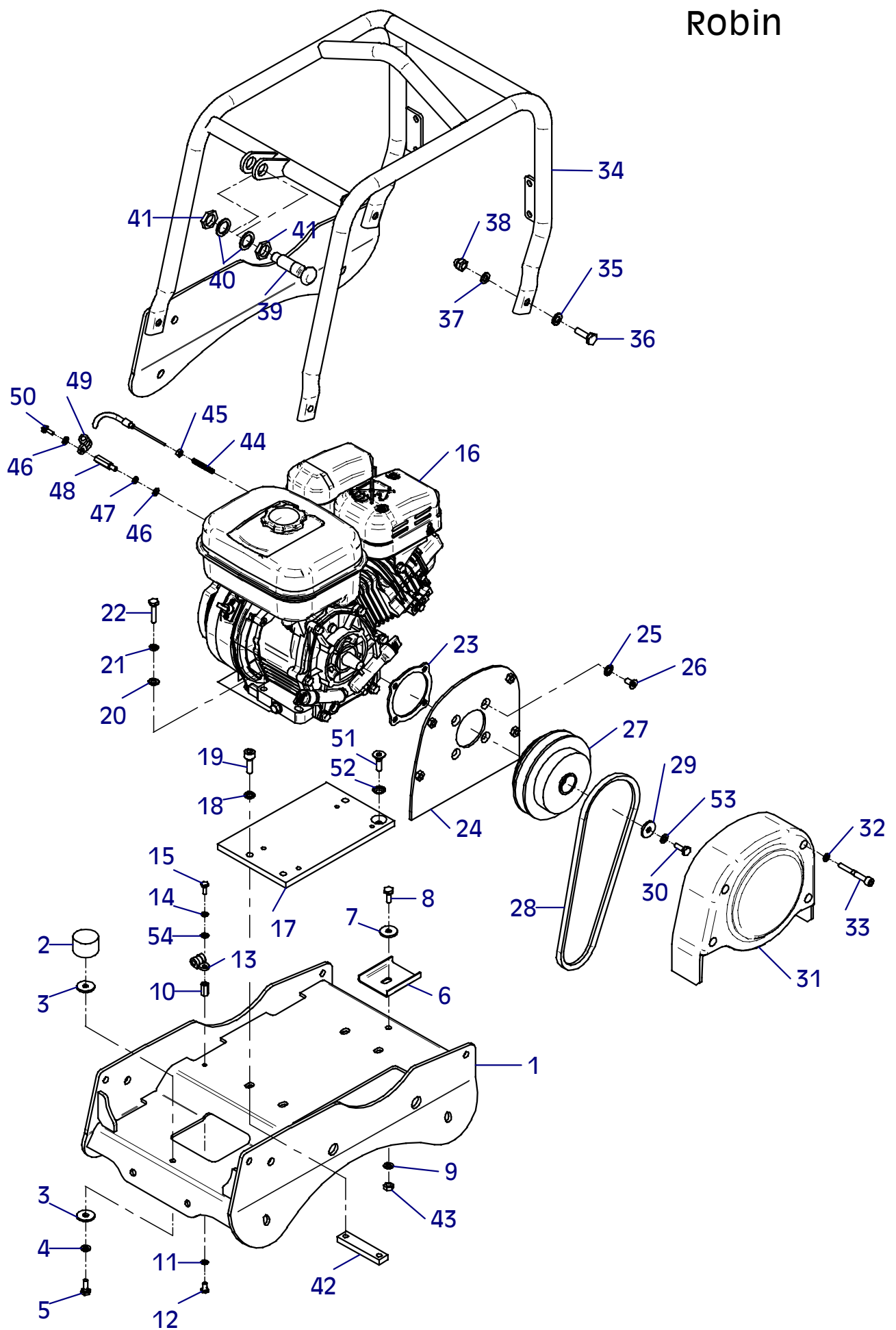

E 3245-0107

E 3247-0107

| Position Ref.No. Repère Posizione Posicion | Menge Quantity Quantité Quantita Cantidad | Teile-Nr. Part-No. No. Référence Nr. d'Ordine No. Referenzia | Hinweis Hints Indications Indicazione Indicaciones | Position Ref. No. Repère Posizione Posicion | Menge Quantity Quantité Quantita Cantidad | Teile-Nr. Part-No. No. Référence Nr. d'Ordine No. Referenzia | Hinweis Hints Indications Indicazione Indicaciones |
|--|---|--|--|---|---|--|--|
| 1 | 1 | 21000233 | | | | | |
| 2 | 2 | 20002285 | | | | | |
| 3 | 2 | 20002351 | | | | | |
| 4 | 2 | 20002284 | | | | | |
| 5 | 3 | 21000019 | | | | | |

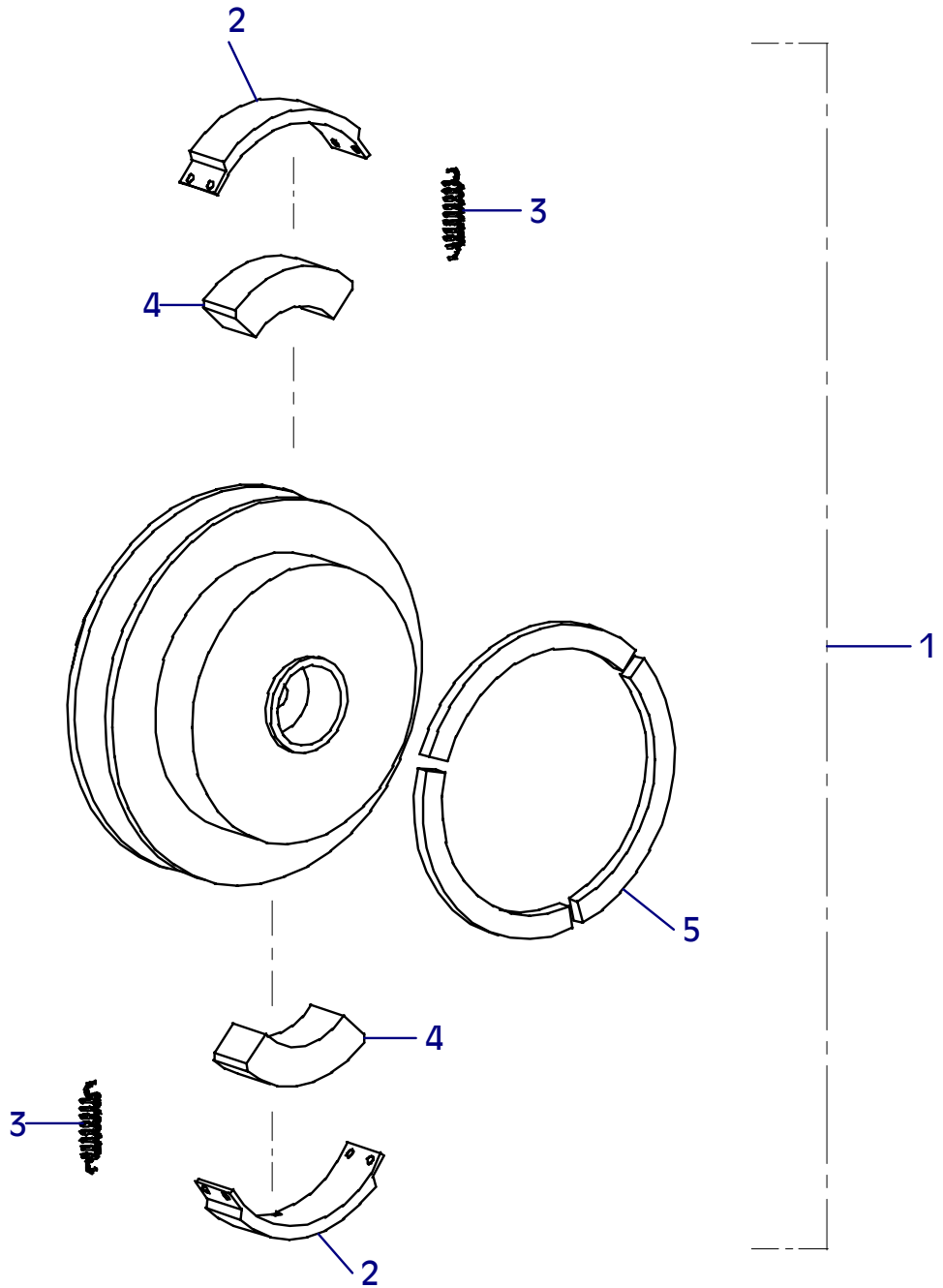

E 3247-0107

E 3234-0606

| Position Ref.No. Repère Posizione Posicion | Menge Quantity Quantité Quantita Cantidad | Teile-Nr. Part-No. No. Référence Nr. d'Ordine No. Referenzia | Hinweis Hints Indications Indicazione Indicaciones | Position Ref. No. Repère Posizione Posicion | Menge Quantity Quantité Quantita Cantidad | Teile-Nr. Part-No. No. Référence Nr. d'Ordine No. Referenzia | Hinweis Hints Indications Indicazione Indicaciones |
|--|---|--|--|---|---|--|--|
| 1 | 1 | 10022580 | | 30 | 1 | 25043005 | DIN933-5/16" |
| 2 | 1 | 20005010 | | 31 | 1 | 10016883 | |
| 3 | 2 | 25049016 | DIN440-R9 | 32 | 4 | 20029011 | VSKZ 8 |
| 4 | 1 | 20029003 | VSK 8 | 33 | 4 | 25044081 | DIN912-M8x60 |
| 5 | 1 | 25038007 | DIN933-M8x20 | 34 | 1 | 10022582 | |
| 6 | 1 | 10016959 | | 35 | 4 | 25048003 | DIN125-A10,5 |
| 7 | 1 | 25049016 | DIN440-R9 | 36 | 4 | 25038015 | DIN933-M10x30 |
| 8 | 1 | 25038007 | DIN933-M8x20 | 37 | 4 | 20029001 | VSK 10 |
| 9 | 1 | 20029003 | VSK 8 | 38 | 4 | 25031028 | DIN1587-M10 |
| 10 | 1 | 20025564 | | 39 | 1 | 20026481 | |
| 11 | 1 | 20029007 | VSK 6 | 40 | 2 | 20025019 | |
| 12 | 1 | 25038002 | DIN933-M6x16 | 41 | 2 | 25025191 | DIN80705-M20x1,5 |
| 13 | 1 | 20007007 | | 42 | 1 | 20007007 | |
| 14 | 1 | 20029007 | VSK 6 | 43 | 1 | 25031003 | DIN934-M8 |
| 15 | 1 | 25038002 | DIN933-M6x16 | 44 | 1 | 20026383 | |
| 16 | 1 | 20001208 | | 45 | 2 | 10017034 | |
| 17 | 1 | 10016928 | | 46 | 1 | 21000335 | |
| 18 | 3 | 20029012 | VSKZ 10 | 47 | 1 | 25047026 | DIN7991-M10x30 |
| 19 | 3 | 25044013 | DIN912-M10x30 | 48 | 1 | 25005004 | DIN6798-V10,5 |
| 20 | 4 | 25049026 | DIN7349-8,4 | 49 | 1 | 20026384 | |
| 21 | 4 | 20029024 | | 50 | 2 | 20026389 | |
| 22 | 4 | 25038010 | DIN933-M8x35 | 54 | 1 | 25048001 | DIN125-A6,4 |
| 23 | 1 | 30047446 | | | | | |
| 24 | 1 | 10022593 | | | | | |
| 25 | 4 | 25005003 | DIN6798-V8,4 | | | | |
| 26 | 4 | 25047062 | DIN7991-5/16"-24UNF | | | | |
| 27 | 1 | 20002096 | | | | | |
| 28 | 1 | 25002083 | | | | | |
| 29 | 1 | 20029021 | SKB 8 | | | | |

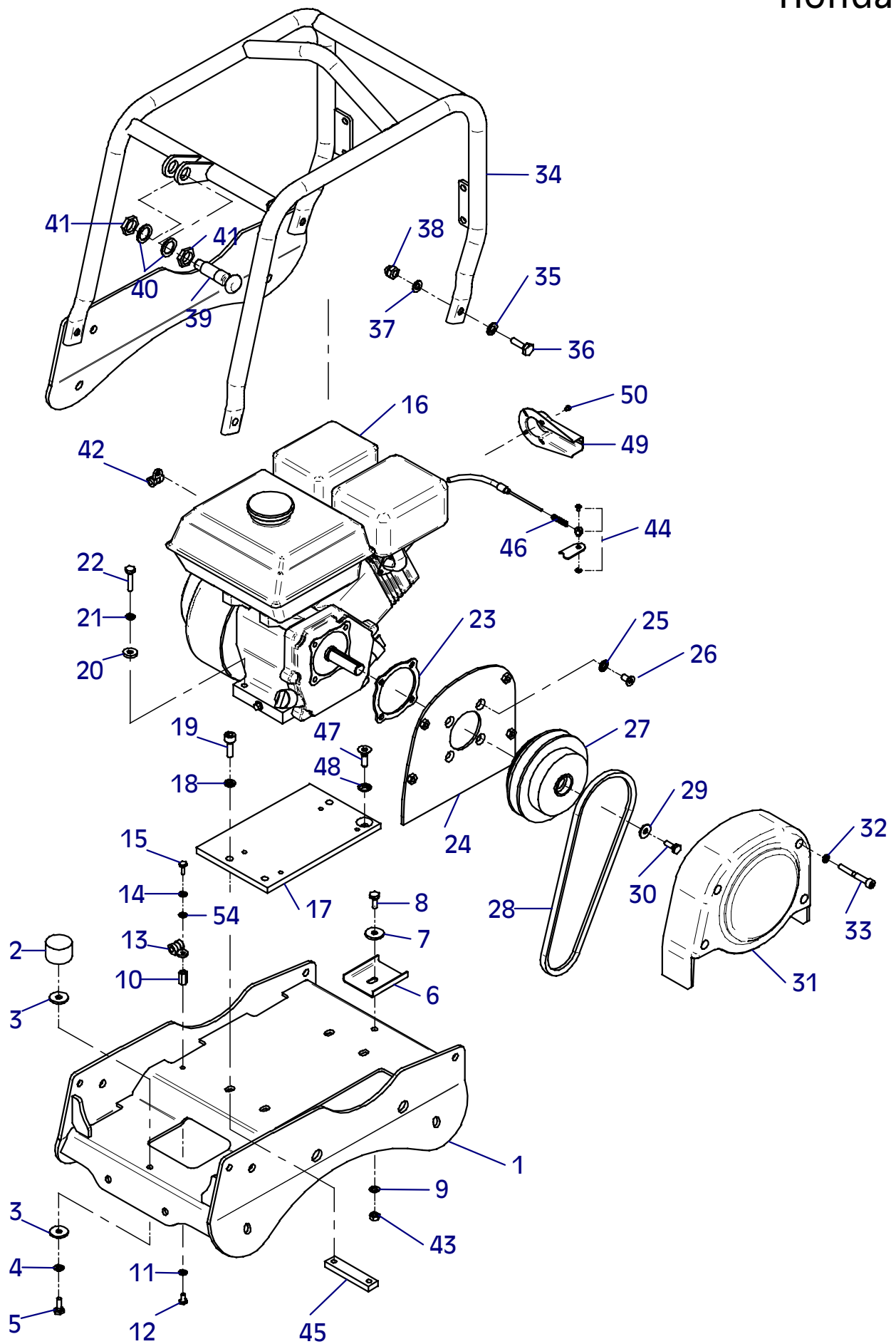

E 3073-0606

| Position Ref.No. Repère Posizione Posicion | Menge Quantity Quantité Quantita Cantidad | Teile-Nr. Part-No. No. Référence Nr. d'Ordine No. Referenzia | Hinweis Hints Indications Indicazione Indicaciones | Position Ref. No. Repère Posizione Posicion | Menge Quantity Quantité Quantita Cantidad | Teile-Nr. Part-No. No. Référence Nr. d'Ordine No. Referenzia | Hinweis Hints Indications Indicazione Indicaciones |
|--|---|--|--|---|---|--|--|
| 1 | 1 | 20002096 | | | | | |
| 2 | 2 | 20002285 | | | | | |
| 3 | 2 | 20002351 | | | | | |
| 4 | 2 | 20002284 | | | | | |
| 5 | 3 | 21000154 | | | | | |

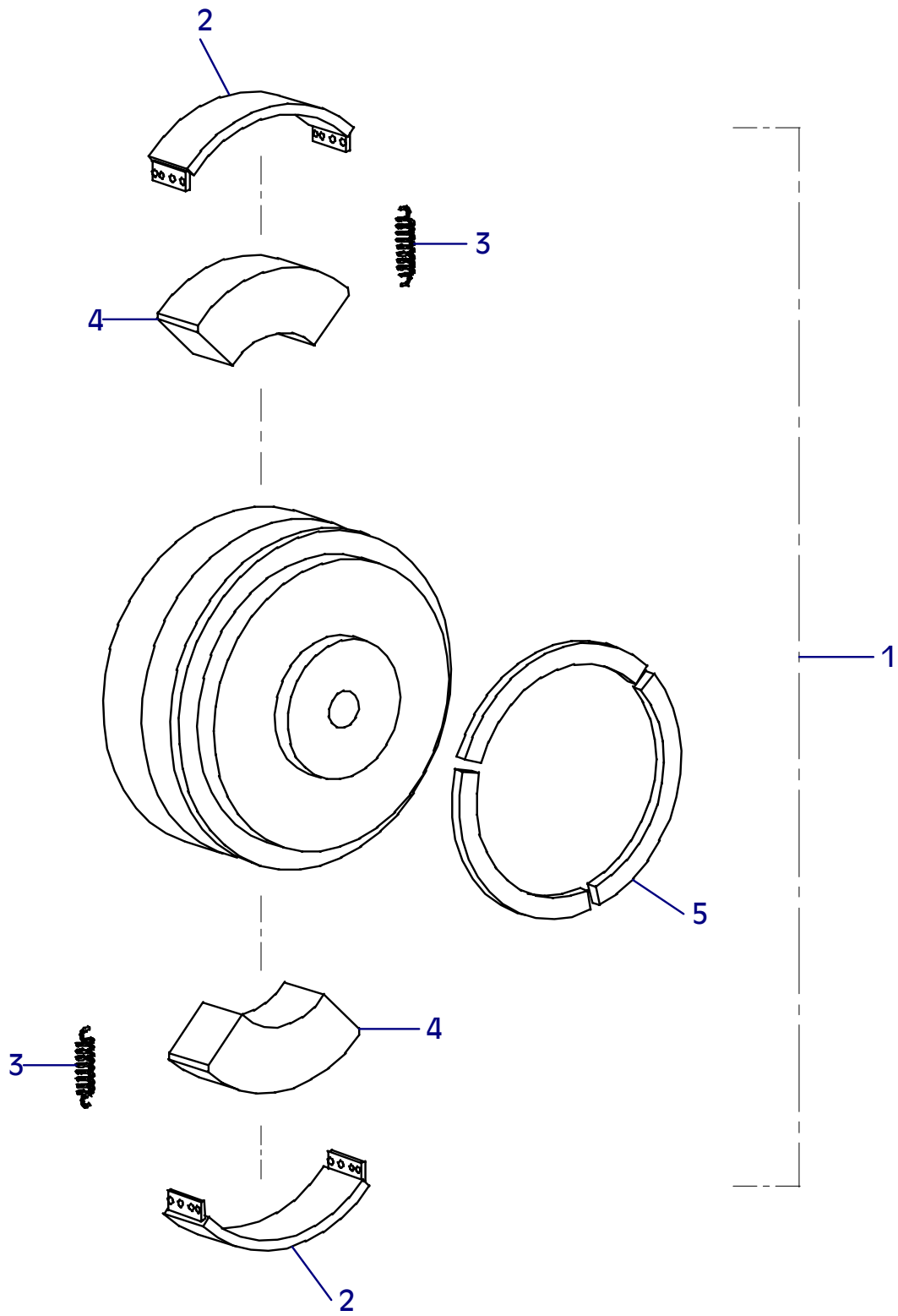

E 3073-0606

E 3338-0309

| Position Ref.No. Repère Posizione Posicion | Menge Quantity Quantité Quantità Cantidad | Teile-Nr. Part-No. No. Référence Nr. d'Ordine No. Referenzia | Hinweis Hints Indications Indicazione Indicaciones | Position Ref. No. Repère Posizione Posicion | Menge Quantity Quantité Quantità Cantidad | Teile-Nr. Part-No. No. Référence Nr. d'Ordine No. Referenzia | Hinweis Hints Indications Indicazione Indicaciones |
|--|---|--|--|---|---|--|--|
| 1 | 1 | 10016872 | | 31 | 1 | 20026542 | |
| 2 | 1 | 25008016 | DIN7603-14x18x1,5 | 32 | 1 | 25008009 | DIN7603-30x36x2 |
| 3 | 1 | 25030002 | DIN908-M14x1,5 | 33 | 1 | 10017050 | |
| 4 | 2 | 25040033 | DIN931-M12x70 | 34 | 1 | 20013296 | |
| 5 | 2 | 20029004 | VSK 12 | 35 | 1 | 25035025 | DIN472-l24x1,2 |
| 6 | 2 | 25048004 | DIN125-A13 | 36 | 1 | 20013297 | |
| 7 | 2 | 10016877 | | 37 | 1 | 25031037 | DIN934-M14 |
| 8 | 2 | 20026493 | | 38 | 1 | 11000649 | |
| 9 | 2 | 10016876 | | | | | |
| 10 | 4 | 20029011 | VSKZ 8 | | | | |
| 11 | 4 | 25044046 | DIN912-M8x55 | | | | |
| 12 | 2 | 20026546 | | | | | |
| 13 | 2 | 20004061 | | | | | |
| 14 | 2 | 20029004 | VSK 12 | | | | |
| 15 | 2 | 25038042 | DIN933-M12x16 | | | | |
| 16 | 1 | 20013298 | | | | | |
| 17 | 1 | 10016869 | | | | | |
| 18 | 1 | 20013282 | | | | | |
| 19 | 1 | 10016867 | | | | | |
| 20 | 1 | 20013284 | | | | | |
| 21 | 1 | 20013286 | | | | | |
| 22 | 1 | 20029024 | | | | | |
| 23 | 1 | 25031003 | DIN934-M8 | | | | |
| 24 | 1 | 10016870 | | | | | |
| 25 | 4 | 20029007 | VSK 6 | | | | |
| 26 | 4 | 25038003 | DIN933-M6x20 | | | | |
| 27 | 1 | 20020035 | | | | | |
| 28 | 1 | 20016390 | | | | | |
| 29 | 1 | 11000650 | | | | | |
| 30 | 1 | 20008067 | | | | | |

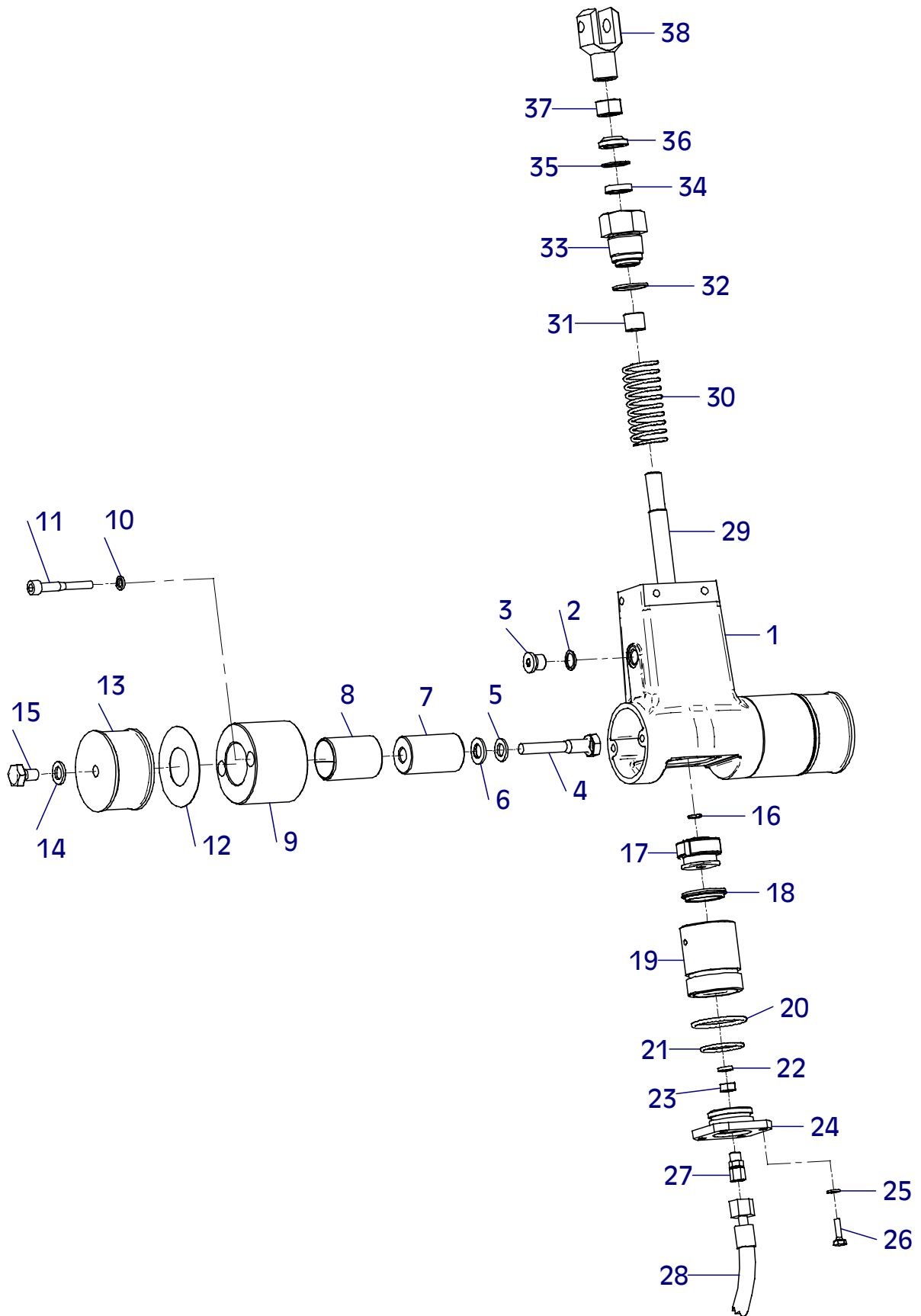

E 3339-0309

| Position Ref.No. Repère Posizione Posicion | Menge Quantity Quantité Quantità Cantidad | Teile-Nr. Part-No. No. Référence Nr. d'Ordine No. Referenzia | Hinweis Hints Indications Indicazione Indicaciones | Position Ref. No. Repère Posizione Posicion | Menge Quantity Quantité Quantità Cantidad | Teile-Nr. Part-No. No. Référence Nr. d'Ordine No. Referenzia | Hinweis Hints Indications Indicazione Indicaciones |
|--|---|--|--|---|---|--|--|
| 1 | 1 | 11000642 | | 30 | 2 | 25048001 | DIN125-A6,4 |
| 2 | 4 | 25038006 | DIN933-M8x16 | 31 | 2 | 20022001 | Tensilock M6 |
| 3 | 4 | 20029031 | SKM 8 | 32 | 1 | 20018021 | |
| 4 | 1 | 11000647 | | 33 | 1 | 20006416 | Lombardini |
| 5 | 7 | 25038006 | DIN933-M8x16 | 33 | 1 | 21000241 | Robin/Honda |
| 6 | 7 | 20029031 | SKM 8 | 34 | 1 | 25044074 | DIN912-M6x12 |
| 7 | 2 | 21000455 | | 35 | 1 | 20022001 | Tensilock M6 |
| 8 | 1 | 11000651 | | 36 | 2 | 20007007 | |
| 9 | 2 | 25031005 | DIN934-M12 | 37 | 2 | 25038002 | DIN933-M6x16 |
| 10 | 1 | 25040047 | DIN931-M12x40 | 38 | 2 | 25048001 | DIN125-A6,4 |
| 11 | 1 | 20029004 | VSK 12 | 39 | 2 | 20022001 | Tensilock M6 |
| 12 | 2 | 11000652 | | | | | |
| 13 | 1 | 25040018 | DIN931-M12x50 | | | | |
| 14 | 1 | 20029004 | VSK 12 | | | | |
| 15 | 1 | 25031019 | DIN936-M12 | | | | |
| 16 | 2 | 21000453 | | | | | |
| 17 | 2 | 11000646 | | | | | |
| 18 | 2 | 10017396 | | | | | |
| 19 | 2 | 21000462 | DIN912-M12x65 | | | | |
| 20 | 2 | 20029013 | VSKZ 12 | | | | |
| 21 | 2 | 11000056 | | | | | |
| 22 | 1 | 11000038 | | | | | |
| 23 | 4 | 25038008 | DIN933-M8x25 | | | | |
| 24 | 4 | 20029003 | VSK 8 | | | | |
| 25 | 1 | 25028012 | DIN915-M8x30 | | | | |
| 26 | 1 | 25031003 | DIN934-M8 | | | | |
| 27 | 1 | 20018134 | | | | | |
| 28 | 1 | 10016358 | Lombardini/Robin | | | | |
| 28 | 1 | 10016938 | Honda | | | | |
| 29 | 2 | 25038070 | DIN933-M6x30 | | | | |

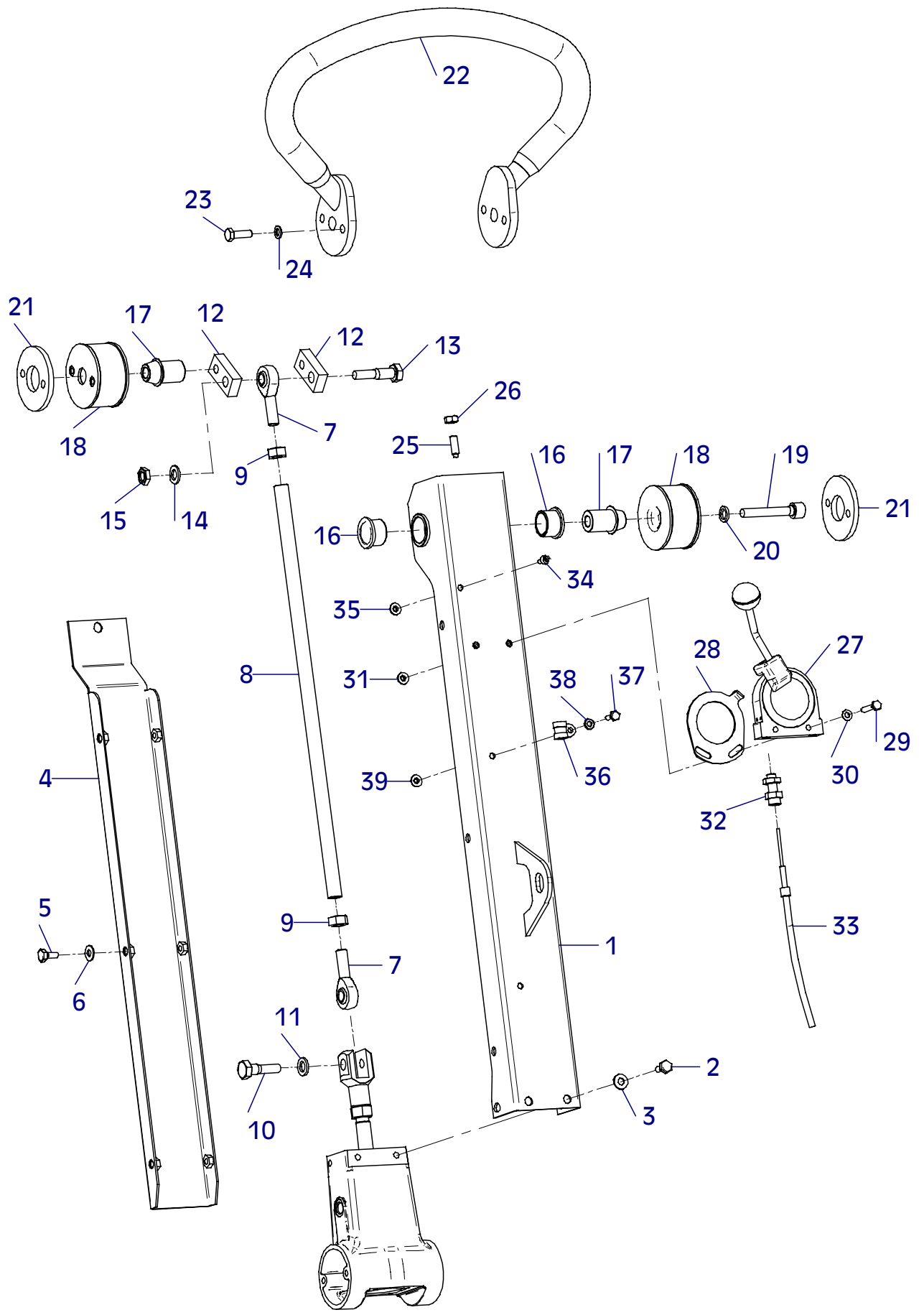

E 3075-0303

| Position Ref.No. Repère Posizione Posicion | Menge Quantity Quantité Quantita Cantidad | Teile-Nr. Part-No. No. Référence Nr. d'Ordine No. Referenzia | Hinweis Hints Indications Indicazione Indicaciones | Position Ref. No. Repère Posizione Posicion | Menge Quantity Quantité Quantita Cantidad | Teile-Nr. Part-No. No. Référence Nr. d'Ordine No. Referenzia | Hinweis Hints Indications Indicazione Indicaciones |
|--|---|--|--|---|---|--|--|
| 1 | 1 | 10022610 | | | | | |
| 2 | 2 | 20025007 | | | | | |
| 3 | 4 | 25048006 | DIN125-A21 | | | | |
| 4 | 2 | 25037002 | | | | | |
| 5 | 1 | 10016239 | | | | | |
| 6 | 1 | 25038060 | DIN933-M10x50 | | | | |
| 7 | 1 | 25031004 | DIN934-M10 | | | | |
| 8 | 1 | 20025508 | | | | | |
| 9 | 1 | 10022609 | | | | | |
| 10 | 2 | 25038014 | DIN933-M10x25 | | | | |
| 11 | 2 | 25048003 | DIN125-A10,5 | | | | |
| 12 | 2 | 20029001 | VSK 10 | | | | |
| 13 | 2 | 25031004 | DIN934-M10 | | | | |

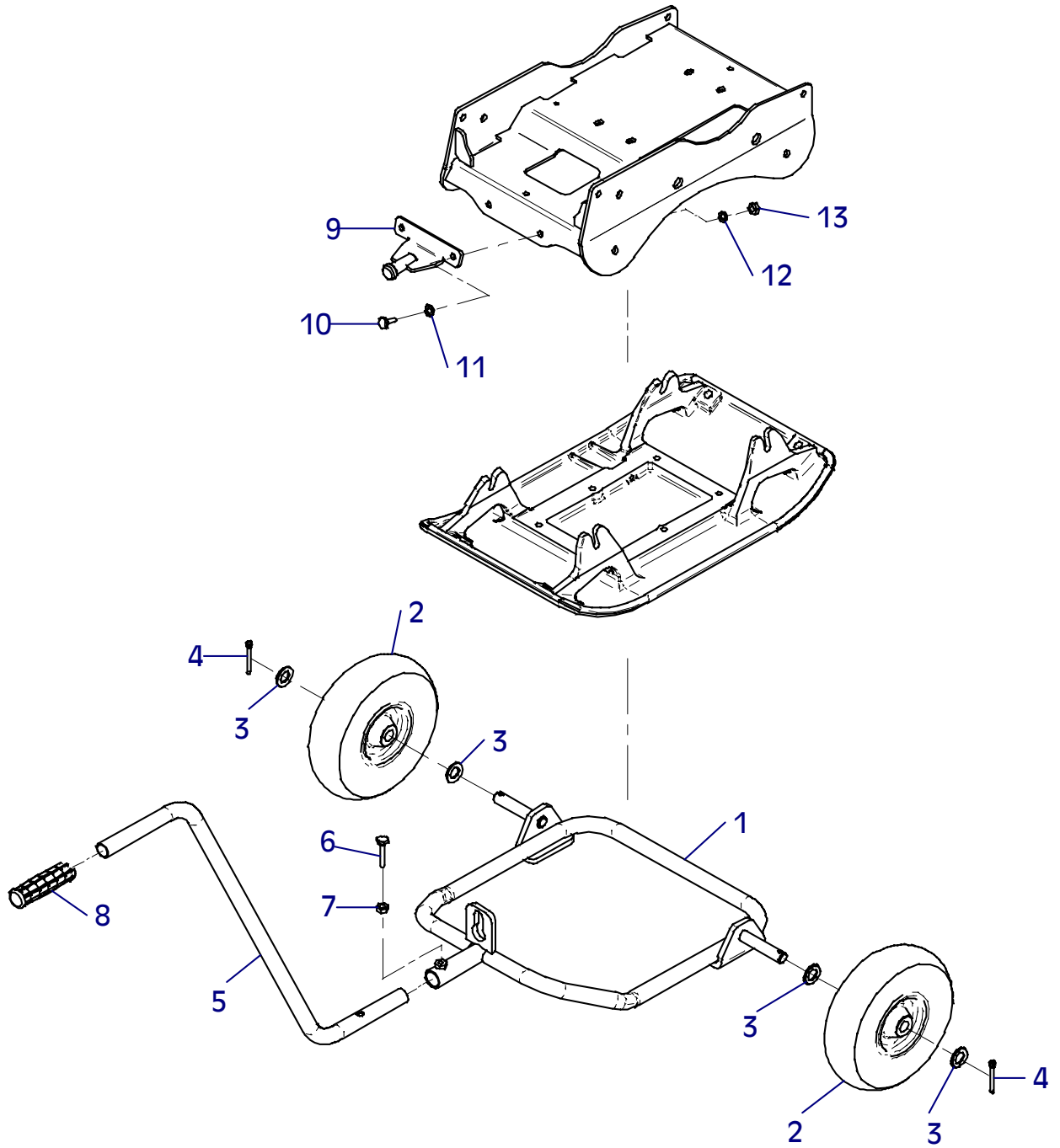

E 3075-0303

E 3123-0204

| Position Ref.No. Repère Posizione Posicion | Menge Quantity Quantité Quantità Cantidad | Teile-Nr. Part-No. No. Référence Nr. d'Ordine No. Referenzia | Hinweis Hints Indications Indicazione Indicaciones | Position Ref. No. Repère Posizione Posicion | Menge Quantity Quantité Quantità Cantidad | Teile-Nr. Part-No. No. Référence Nr. d'Ordine No. Referenzia | Hinweis Hints Indications Indicazione Indicaciones |
|--|---|--|--|---|---|--|--|
| 1 | 1 | 10017186 | | | | | |
| 2 | 2 | 10017187 | | | | | |
| 3 | 4 | 25040049 | DIN931-M12x80 | | | | |
| 4 | 4 | 25048004 | DIN125-A13 | | | | |
| 5 | 4 | 20029004 | VSK 12 | | | | |
| 6 | 4 | 25031005 | DIN934-M12 | | | | |

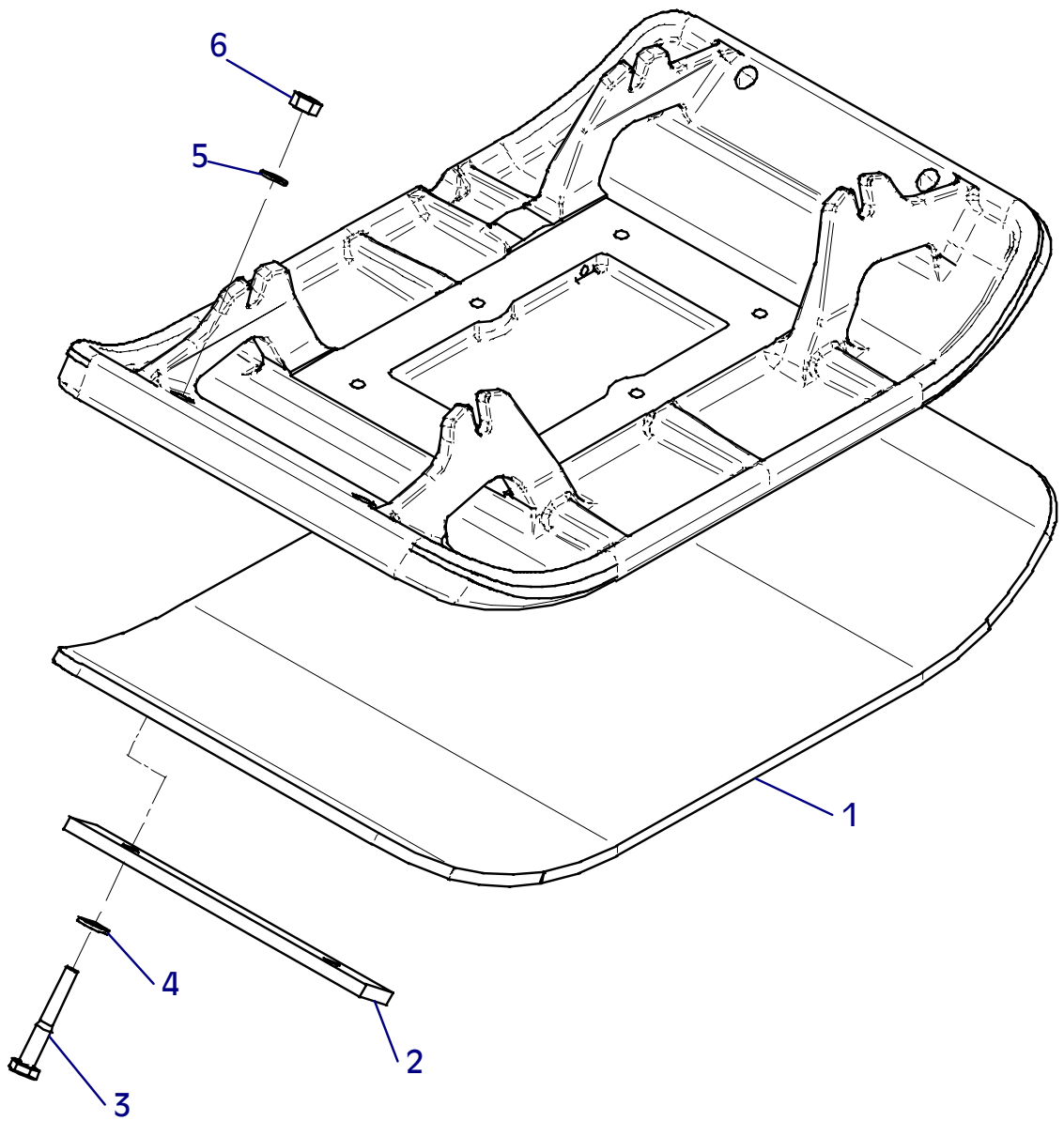

E 3123-0204

E 3124-0105

| Position Ref.No. Repère Posizione Posicion | Menge Quantity Quantité Quantita Cantidad | Teile-Nr. Part-No. No. Référence Nr. d'Ordine No. Referenzia | Hinweis Hints Indications Indicazione Indicaciones | Position Ref. No. Repère Posizione Posicion | Menge Quantity Quantité Quantita Cantidad | Teile-Nr. Part-No. No. Référence Nr. d'Ordine No. Referenzia | Hinweis Hints Indications Indicazione Indicaciones |
|--|---|--|--|---|---|--|--|
| 1 | 1 | 20026575 | | | | | |
| 2 | 1 | 20025719 | | | | | |
| 3 | 1 | 10022641 | | | | | |
| 4 | 4 | 25038008 | DIN933-M8x25 | | | | |
| 5 | 8 | 25048002 | DIN125-A8,4 | | | | |
| 6 | 4 | 25031003 | DIN934-M8 | | | | |
| 7 | 1 | 10017143 | | | | | |
| 8 | 4 | 25038006 | DIN933-M8x16 | | | | |
| 9 | 4 | 20029021 | SKB 8 | | | | |
| 10 | 1 | 20030018 | | | | | |
| 11 | 1 | 25025143 | | | | | |
| 12 | 1 | 20030012 | | | | | |
| 13 | 1 | 20013292 | | | | | |
| 14 | 1 | 10017142 | | | | | |
| 15 | 2 | 20026480 | | | | | |
| 16 | 2 | 20025775 | | | | | |
| 17 | 1 | 10017351 | | | | | |
| 18 | 3 | 25038007 | DIN933-M8x20 | | | | |
| 19 | 1 | 20025671 | | | | | |
| 20 | 1 | 20029022 | SKB 10 | | | | |
| 21 | 1 | 20025829 | | | | | |

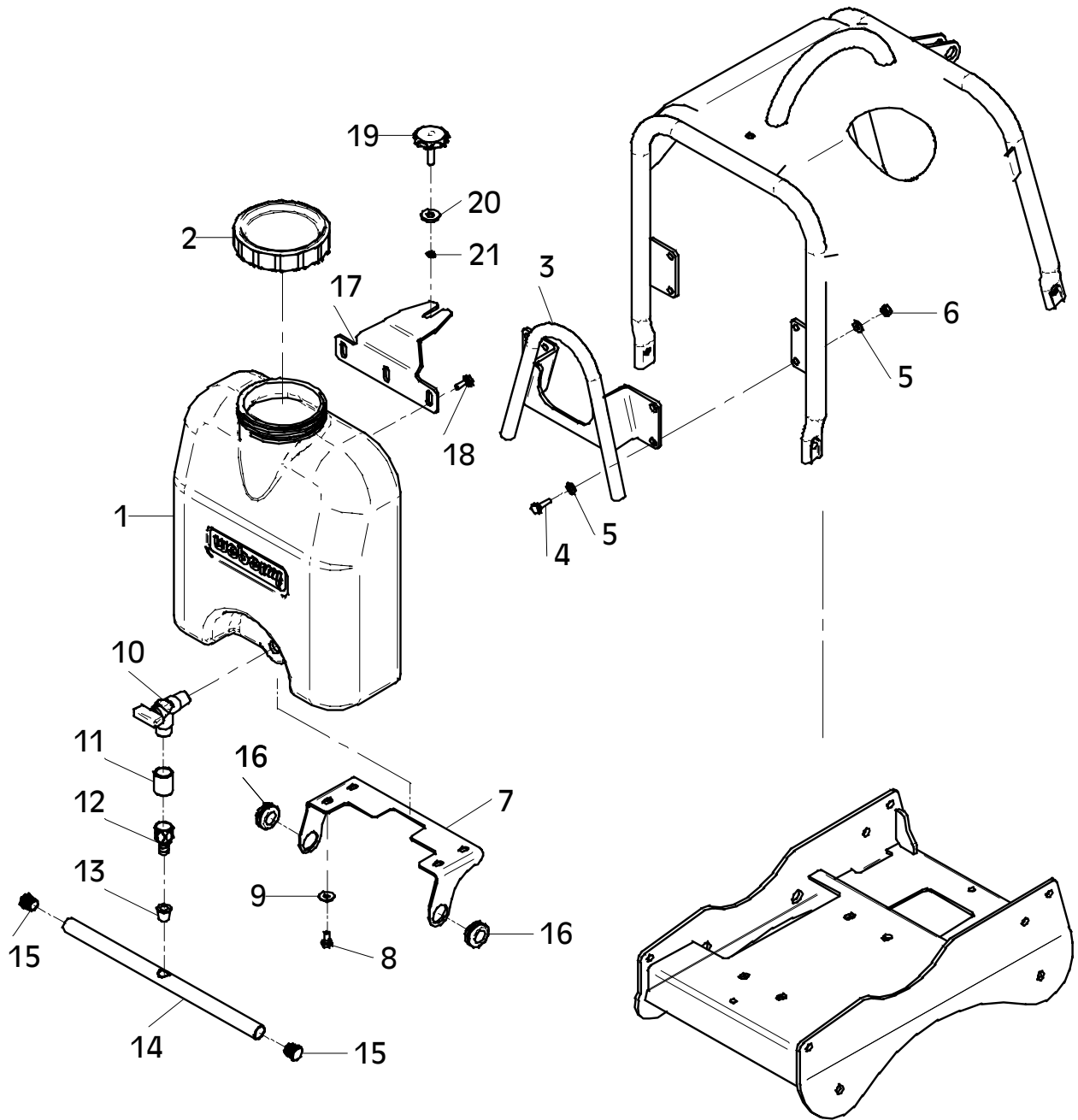

E 3192-0105

| Position Ref.No. Repère Posizione Posicion | Menge Quantity Quantité Quantita Cantidad | Teile-Nr. Part-No. No. Référence Nr. d'Ordine No. Referenzia | Hinweis Hints Indications Indicazione Indicaciones | Position Ref. No. Repère Posizione Posicion | Menge Quantity Quantité Quantita Cantidad | Teile-Nr. Part-No. No. Référence Nr. d'Ordine No. Referenzia | Hinweis Hints Indications Indicazione Indicaciones |
|--|---|--|--|---|---|--|--|
| 1 | 1 | 20026575 | | 31 | 2 | 20029015 | VSKZ 6 |
| 2 | 1 | 20025719 | | | | | |
| 3 | 1 | 10022641 | | | | | |
| 4 | 3 | 25038008 | DIN933-M8x25 | | | | |
| 5 | 6 | 25048002 | DIN125-A8,4 | | | | |
| 6 | 3 | 25031003 | DIN934-M8 | | | | |
| 7 | 1 | 10017143 | | | | | |
| 8 | 4 | 25038006 | DIN933-M8x16 | | | | |
| 9 | 4 | 20029021 | SKB 8 | | | | |
| 10 | 1 | 20030018 | | | | | |
| 11 | 1 | 25025143 | | | | | |
| 12 | 1 | 20030012 | | | | | |
| 13 | 1 | 20013292 | | | | | |
| 14 | 1 | 10017142 | | | | | |
| 15 | 2 | 20026480 | | | | | |
| 16 | 2 | 20025775 | | | | | |
| 17 | 1 | 10022680 | | | | | |
| 18 | 2 | 25038009 | DIN933-M8x30 | | | | |
| 19 | 2 | 25048002 | DIN125-A8,4 | | | | |
| 20 | 2 | 25031003 | DIN934-M8 | | | | |
| 21 | 1 | 10017367 | | | | | |
| 22 | 1 | 10017352 | | | | | |
| 23 | 3 | 25038007 | DIN933-M8x20 | | | | |
| 24 | 1 | 20025671 | | | | | |
| 25 | 1 | 20029022 | SKB 10 | | | | |
| 26 | 1 | 20025829 | | | | | |
| 27 | 1 | 20007230 | | | | | |
| 28 | 1 | 20007231 | | | | | |
| 29 | 1 | 10022679 | | | | | |
| 30 | 2 | 25044123 | DIN912-M6x60 | | | | |

Robin / Honda

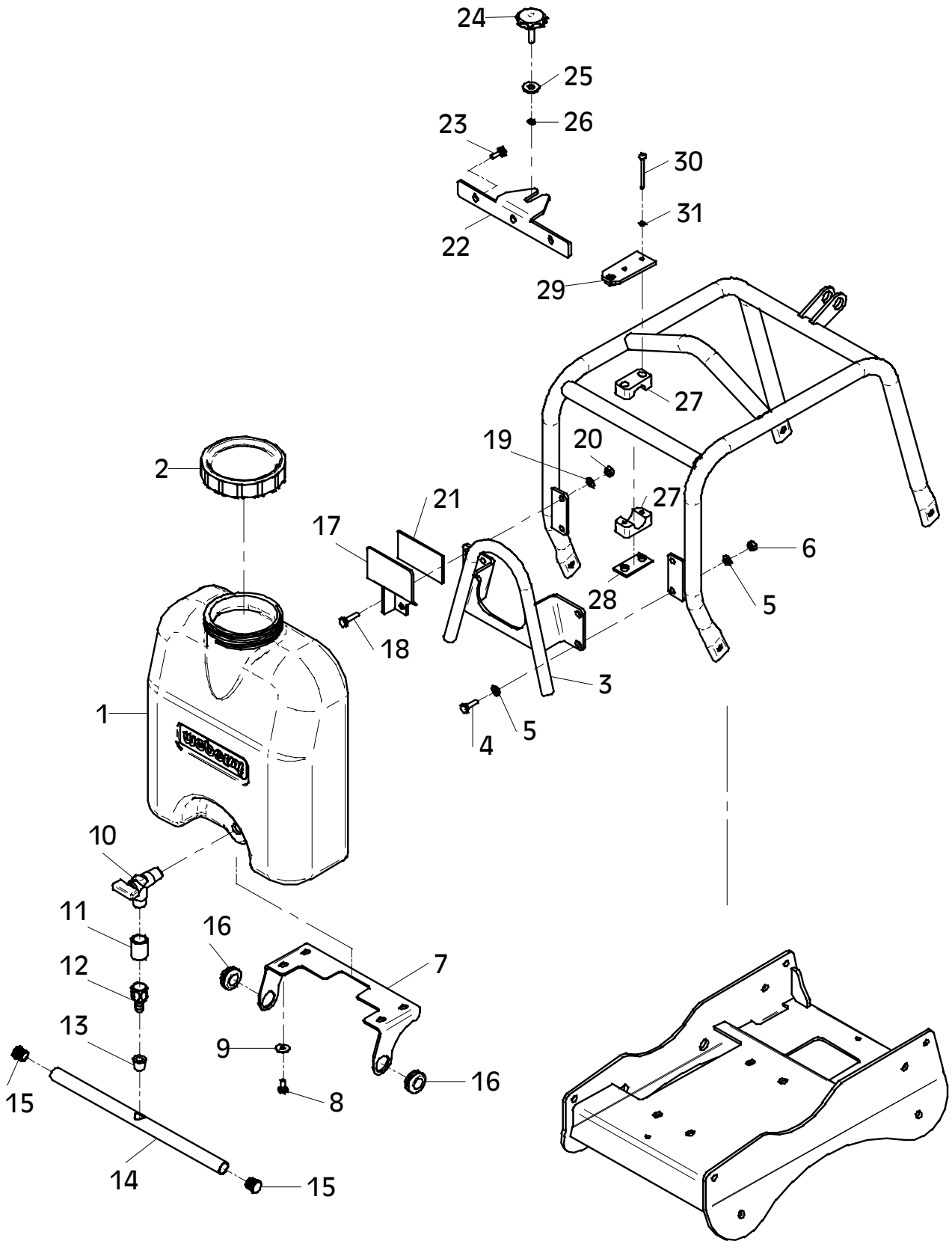

**Wenn Sie Fragen und Anregungen haben, oder sonstige Informationen benötigen,
wenden Sie sich bitte an eine der unten genannten Adressen:**

**For questions and further information refer to one of the
following addresses:**

| | | | |
|--|--|---|--|
| <p>In Deutschland</p> <p>In Germany</p> | <p>WEBER Maschinenteknik GmbH Postfach 2153 57329 Bad Laasphe – Rückershausen</p> <p>Information / information: E-mail: info@webermt.de</p> <p>Ersatzteile / spare parts: E-mail: parts@webermt.de</p> | <p>Telefon / phone:</p> <p>Telefax / fax:</p> <p>Telefax / fax:</p> | <p>+49 (0) 2754 / 3980 Zentrale / switchboard</p> <p>+49 (0) 2754 / 398101 Zentrale / switchboard</p> <p>+49 (0) 2754 / 398102 Ersatzteile / spare parts direct dial</p> |
| <p>In Holland</p> <p>In Netherlands</p> | <p>WEBER Maschinenteknik B.V. Graafschap Hornelaan 159 6001 AC Weert</p> <p>E-mail: info@webermt.nl</p> | <p>Telefon / phone:</p> <p>Telefax / fax:</p> | <p>+31 (0) 495 / 530215</p> <p>+31 (0) 495 / 541839</p> |
| <p>In Frankreich</p> <p>In France</p> | <p>WEBER Technologie S.A.R.L. 26, rue d'Arsonval 69680 Chassieu</p> <p>E-mail: france@webermt.com</p> | <p>Telefon / phone:</p> <p>Telefax / fax:</p> | <p>+33 (0) 472 / 791020</p> <p>+33 (0) 472 / 791021</p> |
| <p>In Polen</p> <p>In Poland</p> | <p>WEBER Maschinenteknik SP.ZO.O. ul. Grodziska 7 05-830 Stara Wies / Nadarzyn</p> <p>E-mail: info@webermt.com.pl</p> | <p>Telefon / phone:</p> <p>Telefax / fax:</p> | <p>+48 (0) 22 / 7397080 +48 (0) 22 / 7397081</p> <p>+48 (0) 22 / 7397082</p> |
| <p>In USA, Kanada</p> <p>In USA, Canada</p> | <p>WEBER Machine (USA), Inc. 40 Johnson Ave 112 Bangor, ME 04401 USA</p> <p>E-mail: usa@webermt.com</p> | <p>Telefon / phone:</p> <p>Telefax / fax:</p> | <p>+1 (0) 207 / 9474990</p> <p>+1 (0) 207 / 9475452</p> |
| <p>In Südamerika</p> <p>In South America</p> | <p>WEBER Maschinenteknik do Brasil Ltda. Rua Sete de Setembro, 275 93332-470 Novo Hamburgo, RS Brasil</p> <p>E-mail: webermt@webermt.com.br</p> | <p>Telefon / phone:</p> <p>Telefax / fax:</p> | <p>+55 (0) 51 / 5873044</p> <p>+55 (0) 51 / 5872271</p> |

<http://www.webermt.com>

