

## CR 3

0116121 - 0116129



Spare parts  
Spares  
Pièces de rechange  
Piezas de recambio  
Ricambi  
Peças de reposição  
Piese de schimb  
Náhradných dielov  
Reserve Teile  
Części zamienne



Weber Maschinentechnik GmbH  
D- 57334 Bad Laasphe / Germany  
Tel. +49 (0) 2754 / 398-0  
Fax. +49 (0)2754 / 398-101  
E-Mail: [info@webermt.de](mailto:info@webermt.de)  
[www.webermt.com](http://www.webermt.com)



BITTE, NOTIEREN SIE SERIENNUMMER UND MOTORNUMMER IHRER MASCHINE:

PLEASE WRITE DOWN SERIALNUMBERS OF MACHINE AND ENGINE:

NOTEZ SVP LE NUMERO DE SERIE ET LE NUMERO DU MOTEUR DE VOTRE MACHINE:

SI PREGA DI ANNOTARE SEMPRE I NUMERI DI SERIE SIA DELLA VS. MACCHINA CHE DEL MOTORE:

MAQUINA: ROGAMOS ANOTEN EL NUMERO DE SERIE Y NUMERO DE MOTOR DE SU MAQUINA:

PROSIMY ZANOTOWAĆ NUMER MASZYNY I SILNIKA

MASCHINE  
MACHINE  
MACCHINA  
MAQUINA  
MASZYNA

# # #
-------------

MOTOR  
ENGINE  
MOTEUR  
MOTORE  
SILNIK

# # #
-------------

ZUR VERMEIDUNG VON FEHLLIEFERUNGEN UND VERZÖGERUNGEN SIND BEI DER BESTELLUNG VON ERSATZTEILEN FOLGENDE ANGABEN UNBEDINGT ERFORDERLICH:

- MASCHINENTYP
- SERIENNUMMER DER MASCHINE
- SERIENNUMMER DES MOTORS (BEI MOTORTEILEN)
- TEILENUMMER
- BESTELLMENGE

TO AVOID ERRORS IN DELIVERY PLEASE STATE THESE PARTICULARS WHEN ORDERING:

- TYPE OF MACHINE
- SERIAL NO. OF MACHINE
- SERIAL NO. OF ENGINE (ON ENGINE PARTS)
- PART-NO.
- QUANTITY REQUIRED

AFIN D'EVITER DES ERREURS DE COMMANDE ET DES RETARDS DE LIVRAISON IL EST NECESSAIRE D'INDIQUER LES CARACTERISTIQUES SUIVANTES:

- TYPE DE MACHINE
- LE NUMERO DE SERIE DE LA MACHINE
- LE NUMERO DE SERIE DU MOTEUR
- LE NUMERO D'IDENTITE DE LA PIECE
- LA QUANTITE SOUHAITEE

ONDE EVITARE DISGUIDI E RITARDI NELLE CONSEGNE DIE RICAMBI SI PREGA DI INDICARE SEMPRE:

- TIPO DELLA MACCHINA
- NUMERO DI SERIE DELLA MACCHINA
- NUMERO DI SERIE DEL MOTORE (SE SI RICHIEDONO PEZZI DEL MOTORE)
- NUMERO D'ORDINE DIE SINGOLI RICAMBI
- QUANTITA

A FI DE EVITAR ERRORES DE ENTREGA, ROGAMOS INDIQUEN LOS SIGUIENTES DATOS CUANDO PASE PEDIDOS DE RECAMBIO:

- MODELO DE MAQUINA
- NO. DE SERIE DE LA MAQUINA
- NO. DE SERIE DEL MOTOR (EN PIEZAS PARA MOTOR)
- REFERENCIA DEL RECAMBIO
- CANTIDAD PEDIDA

PROSIMY O PODANIE NASTĘPUJĄCYCH DANYCH PRZY SKŁADANIU ZAMÓWIENIA.

- TYP MASZYNY
- NUMER SERYJNY MASZYNY
- NUMER SERYJNY SILNIKA (PRZY CZĘŚCIACH DO SILNIKA)
- NUMER CZĘŚCI ZAMIEWNNEJ
- ZAMAWIANA ILOŚĆ

## E 3320-0212

Position Ref.No. Repère Posizione Posicion	Menge Quantity Quantité Quantita Cantidad	Teile-Nr. Part-No. No. Référence Nr. d'Ordine No. Referenzia	Hinweis Hints Indications Indicazione Indicaciones	Position Ref. No. Repère Posizione Posicion	Menge Quantity Quantité Quantita Cantidad	Teile-Nr. Part-No. No. Référence Nr. d'Ordine No. Referenzia	Hinweis Hints Indications Indicazione Indicaciones
1	1	11001046					
2	1	25030002	DIN908-M14x1,5				
3	4	25038023	DIN933-M16x25				
4	4	20029002	VSK 16				
5	1	20013302					
6	1	11001047					
7	10	25040040	DIN931-M10x35				
8	10	20029025					
9	4	20004062					
10	4	11000378					
11	4	20029023	SKB 12				
12	4	25031005	DIN934-M12				
13	1	20007066					
14	1	25038007	DIN933-M8x20				
15	1	20029024					
16	1	25049026	DIN7349-8,4				
17	1	11000377					
18	3	25038006	DIN933-M8x16				
19	3	20029003	VSK 8				
20	1	11000943					
21	2	21000587	DIN7964-M8x60				
22	2	21000585	DIN7964-M8x40				
23	4	20029011	VSKZ 8				
24	4	11000866					
25	0	11001271	t = 1				
25	0	11001273	t = 2				

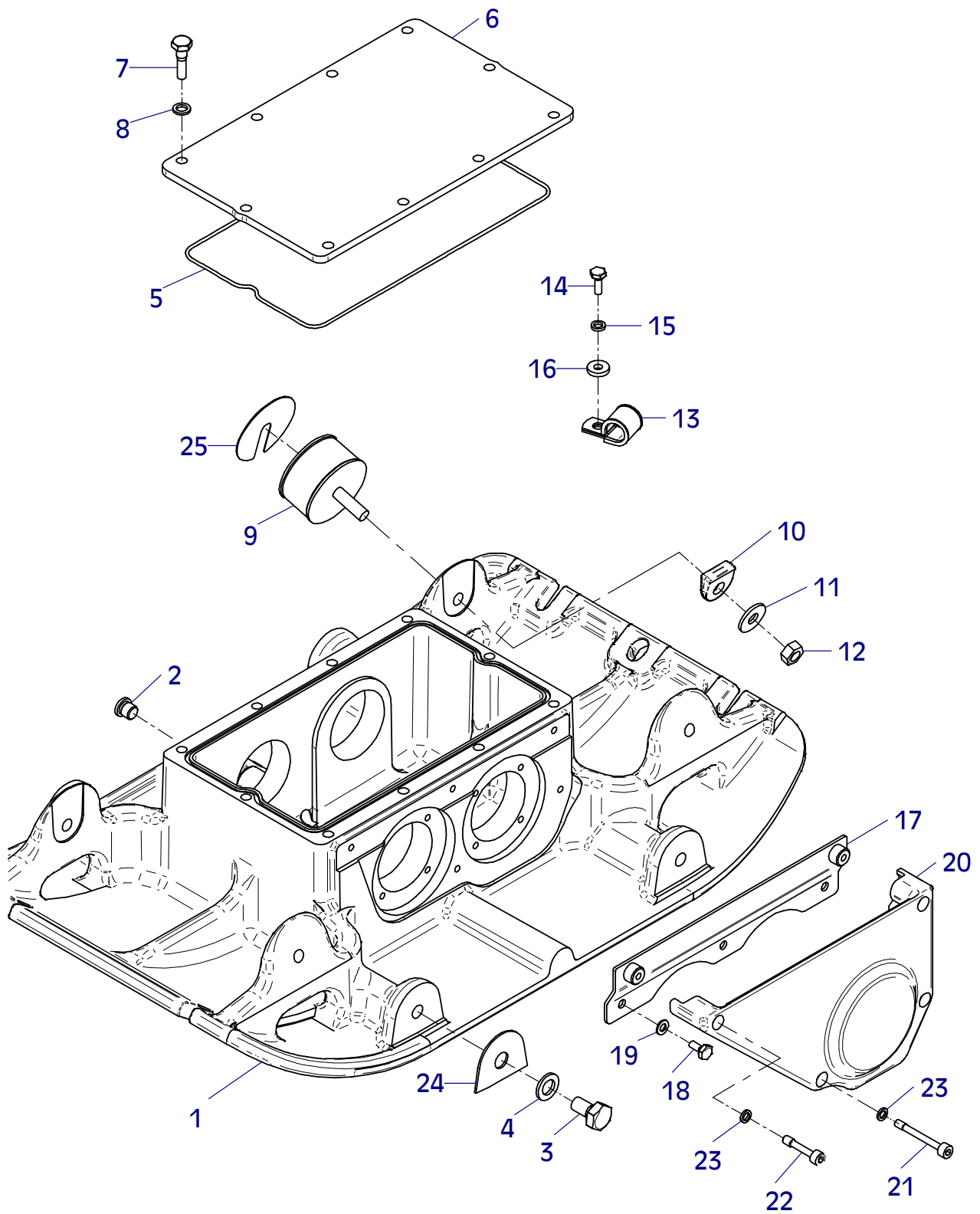

E 3320-0212

## E 3321-0808

Position Ref.No. Repère Posizione Posicion	Menge Quantity Quantité Quantita Cantidad	Teile-Nr. Part-No. No. Référence Nr. d'Ordine No. Referenzia	Hinweis Hints Indications Indicazione Indicaciones	Position Ref. No. Repère Posizione Posicion	Menge Quantity Quantité Quantita Cantidad	Teile-Nr. Part-No. No. Référence Nr. d'Ordine No. Referenzia	Hinweis Hints Indications Indicazione Indicaciones
1	2	10016060					
2	2	20013269					
3	8	25044100	DIN912-M8x16				
4	8	20029011	VSKZ 8				
5	1	10016061					
6	1	20013269					
7	4	25044100	DIN912-M8x16				
8	4	20029011	VSKZ 8				
9	1	11000348					
10	1	20013269					
11	4	25044100	DIN912-M8x16				
12	4	20029011	VSKZ 8				
13	1	25030016	DIN910-M10x1				
14	1	25008012	DIN7603-10x16x1				
15	1	20020119					

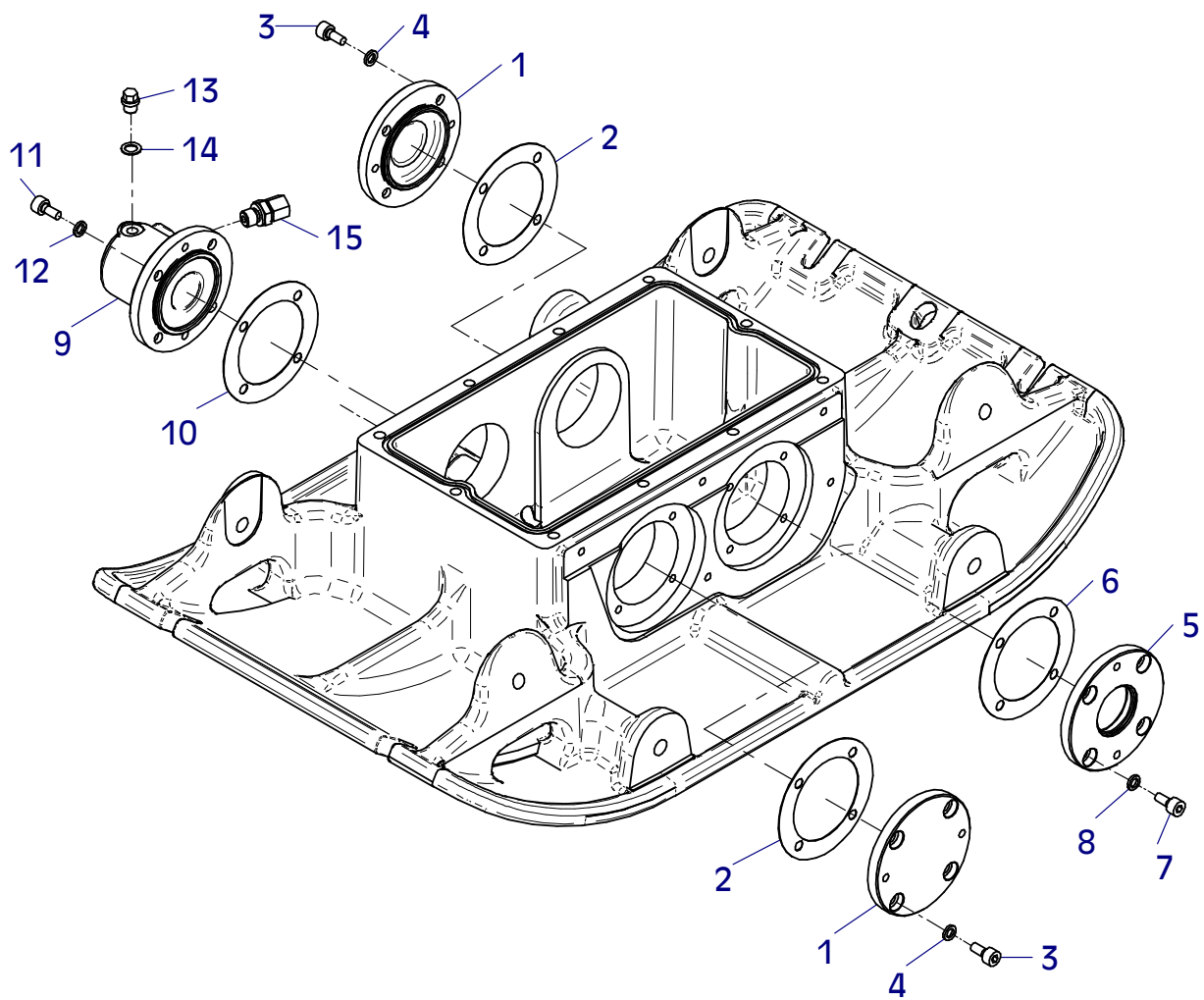

E 3321-0808

## E 3322-0509

Position Ref.No. Repère Posizione Posicion	Menge Quantity Quantité Quantità Cantidad	Teile-Nr. Part-No. No. Référence Nr. d'Ordine No. Referenzia	Hinweis Hints Indications Indicazione Indicaciones	Position Ref. No. Repère Posizione Posicion	Menge Quantity Quantité Quantità Cantidad	Teile-Nr. Part-No. No. Référence Nr. d'Ordine No. Referenzia	Hinweis Hints Indications Indicazione Indicaciones
1	1	11000353					
2	1	11000354					
3	2	21000358	DIN912-M10x40-10.9				
4	2	25025245					
5	1	11000345					
6	1	21000228					
7	1	25034018	DIN471-A75x2,5				
8	1	25001045					
9	1	25034006	DIN471-A35x1,5				
10	1	25035003	DIN472-I62x2				
11	1	11000346					
12	2	25001103					
13	1	21000290					
14	1	25048003	DIN125-A10,5				
15	1	25035011	DIN472-I20				
16	1	11000660					
17	1	11000355					
18	1	25027004	DIN914-M8x16				
19	1	25035025	DIN472-I24x1,2				
20	2	25001705					
21	1	25034032	DIN471-A9x1				
22	1	10017370					
23	1	20013270					



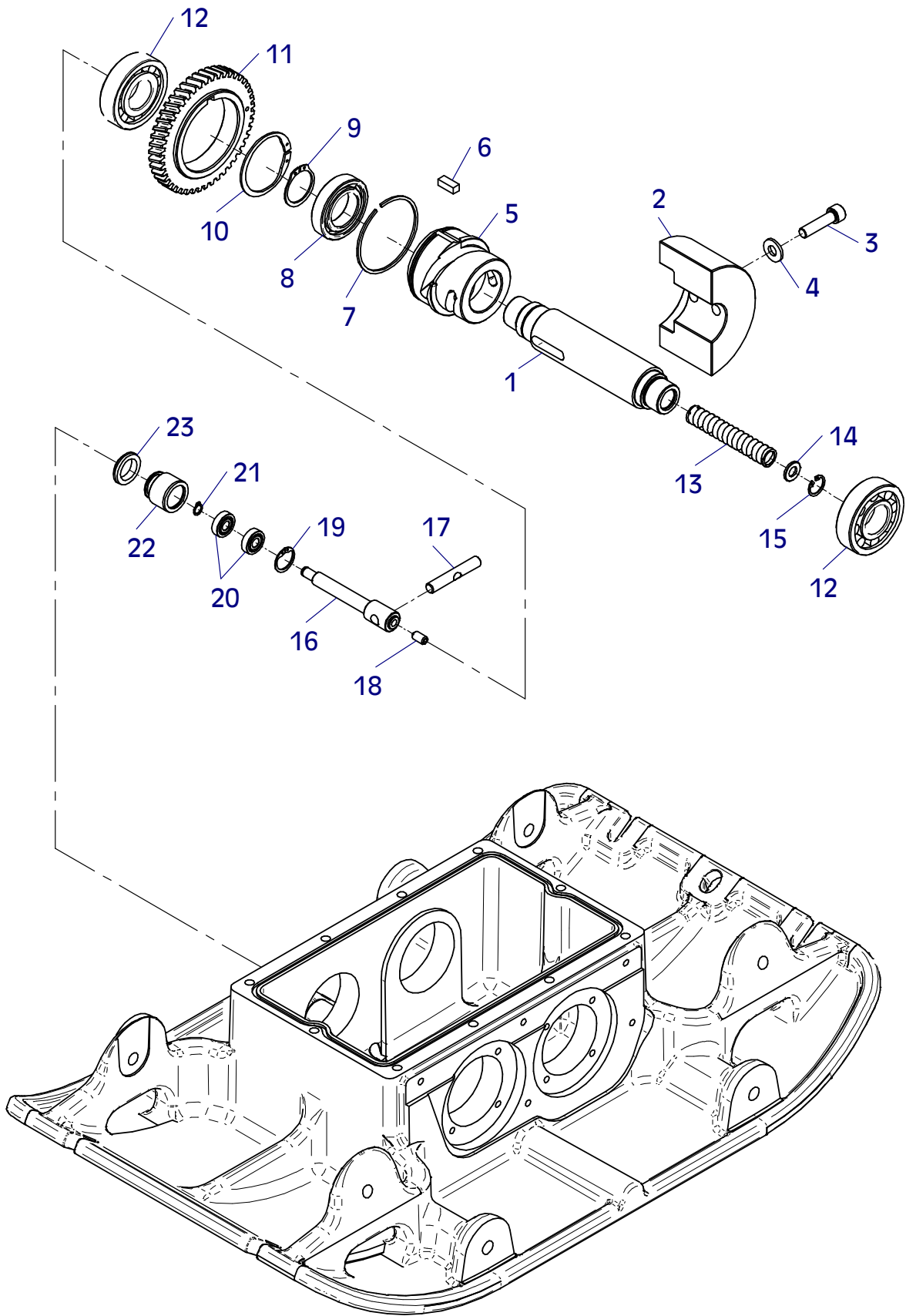

E 3322-0509

## E 3323-0808

Position Ref.No. Repère Posizione Posicion	Menge Quantity Quantité Quantita Cantidad	Teile-Nr. Part-No. No. Référence Nr. d'Ordine No. Referenzia	Hinweis Hints Indications Indicazione Indicaciones	Position Ref. No. Repère Posizione Posicion	Menge Quantity Quantité Quantita Cantidad	Teile-Nr. Part-No. No. Référence Nr. d'Ordine No. Referenzia	Hinweis Hints Indications Indicazione Indicaciones
1	1	11000351					
2	1	11000350					
3	2	21000358	DIN912-M10x40-10.9				
4	2	25025245					
5	1	11000347					
6	1	25015016					
7	2	25001103					
8	1	25034020	DIN471-A38x1,75				
9	1	25017047					
10	1	11000356					
11	1	10007370					
12	1	20029001	VSK 10				
13	1	10016071					

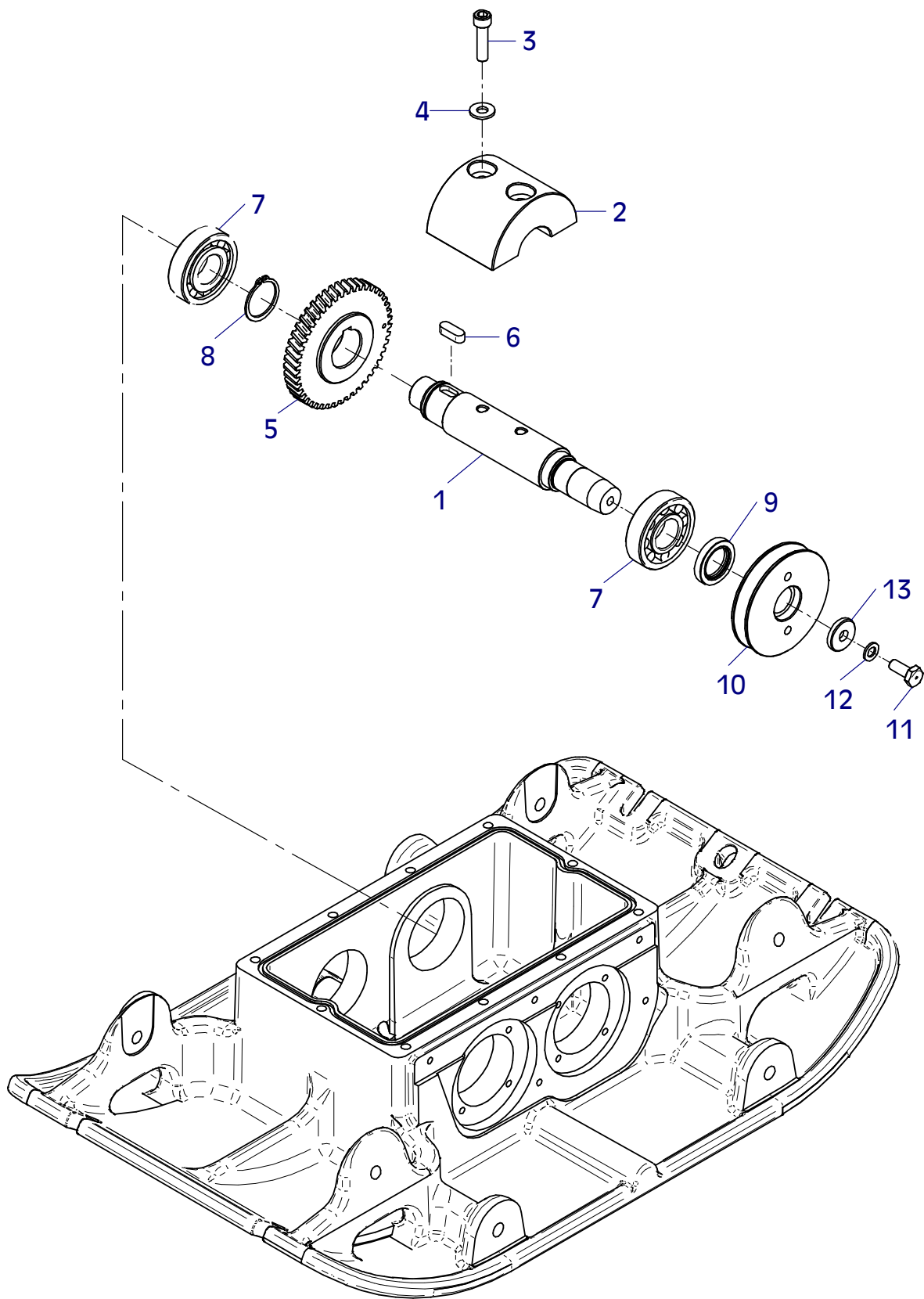

E 3323-0808

## E 3324-0611

Position Ref.No. Repère Posizione Posicion	Menge Quantity Quantité Quantita Cantidad	Teile-Nr. Part-No. No. Référence Nr. d'Ordine No. Referenzia	Hinweis Hints Indications Indicazione Indicaciones	Position Ref. No. Repère Posizione Posicion	Menge Quantity Quantité Quantita Cantidad	Teile-Nr. Part-No. No. Référence Nr. d'Ordine No. Referenzia	Hinweis Hints Indications Indicazione Indicaciones
1	1	11000406					
2	4	25038019	DIN933-M12x25				
3	8	20029023	SKB 12				
4	1	25009021					
5	1	11000442					
6	4	25038021	DIN933-M12x35				
7	8	20029023	SKB 12				
8	4	25031027	DIN1587-M12				
9	1	11000464					
10	4	25038006	DIN933-M8x16				
11	4	20029021	SKB 8				
12	2	20005019					
13	2	20022025	Tensilock M10x16				

CR3

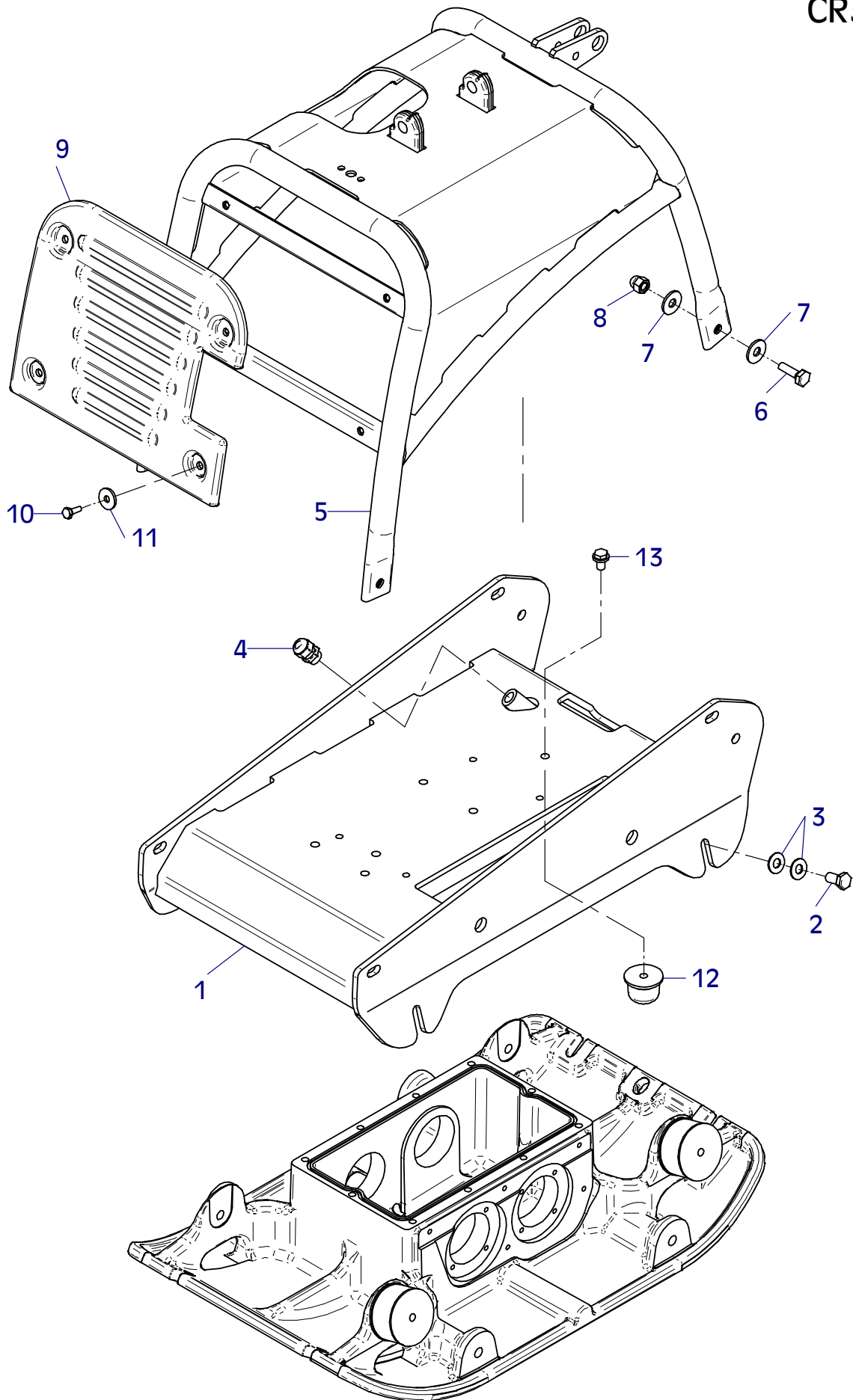

E 3324-0611

## E 3325-0611

Position Ref.No. Repère Posizione Posicion	Menge Quantity Quantité Quantita Cantidad	Teile-Nr. Part-No. No. Référence Nr. d'Ordine No. Referenzia	Hinweis Hints Indications Indicazione Indicaciones	Position Ref. No. Repère Posizione Posicion	Menge Quantity Quantité Quantita Cantidad	Teile-Nr. Part-No. No. Référence Nr. d'Ordine No. Referenzia	Hinweis Hints Indications Indicazione Indicaciones
1	1	11000411					
2	4	25038019	DIN933-M12x25				
3	8	20029023	SKB 12				
4	1	25009021					
5	1	11000442					
6	4	25038021	DIN933-M12x35				
7	8	20029023	SKB 12				
8	4	25031027	DIN1587-M12				
9	1	11000464					
10	4	25038006	DIN933-M8x16				
11	4	20029021	SKB 8				
12	2	20005019					
13	2	20022025	Tensilock M10x16				

CR3 E

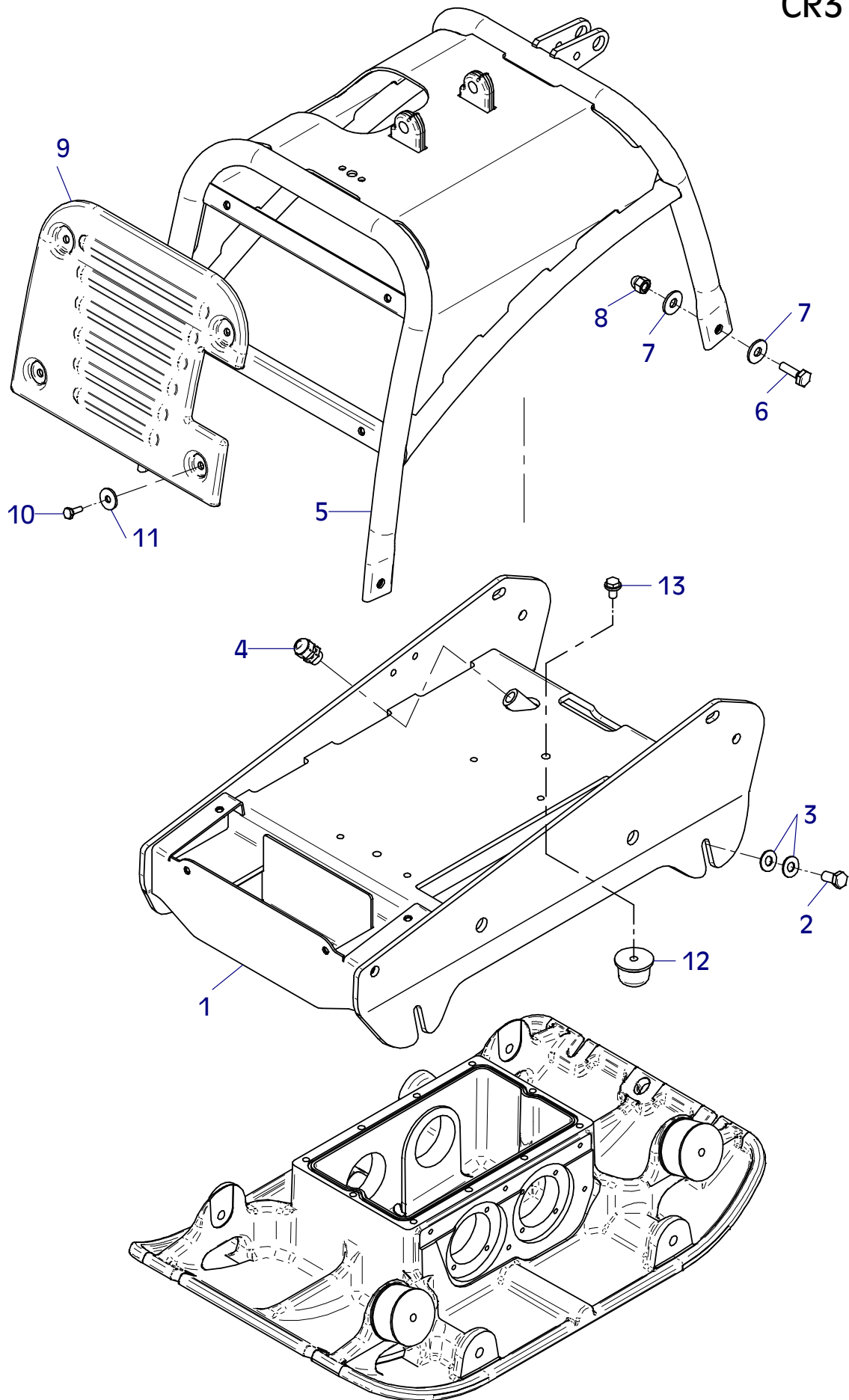

E 3325-0611

## E 3326-0611

Position Ref.No. Repère Posizione Posicion	Menge Quantity Quantité Quantita Cantidad	Teile-Nr. Part-No. No. Référence Nr. d'Ordine No. Referenzia	Hinweis Hints Indications Indicazione Indicaciones	Position Ref. No. Repère Posizione Posicion	Menge Quantity Quantité Quantita Cantidad	Teile-Nr. Part-No. No. Référence Nr. d'Ordine No. Referenzia	Hinweis Hints Indications Indicazione Indicaciones
1	1	11000406					
2	4	25038019	DIN933-M12x25				
3	8	20029023	SKB 12				
4	1	25009021					
5	1	11000422					
6	4	25038021	DIN933-M12x35				
7	8	20029023	SKB 12				
8	4	25031027	DIN1587-M12				
9	1	11000530					
10	4	25038006	DIN933-M8x16				
11	4	20029021	SKB 8				
12	2	20005019					
13	2	20022025	Tensilock M10x16				



# CR3 Hd

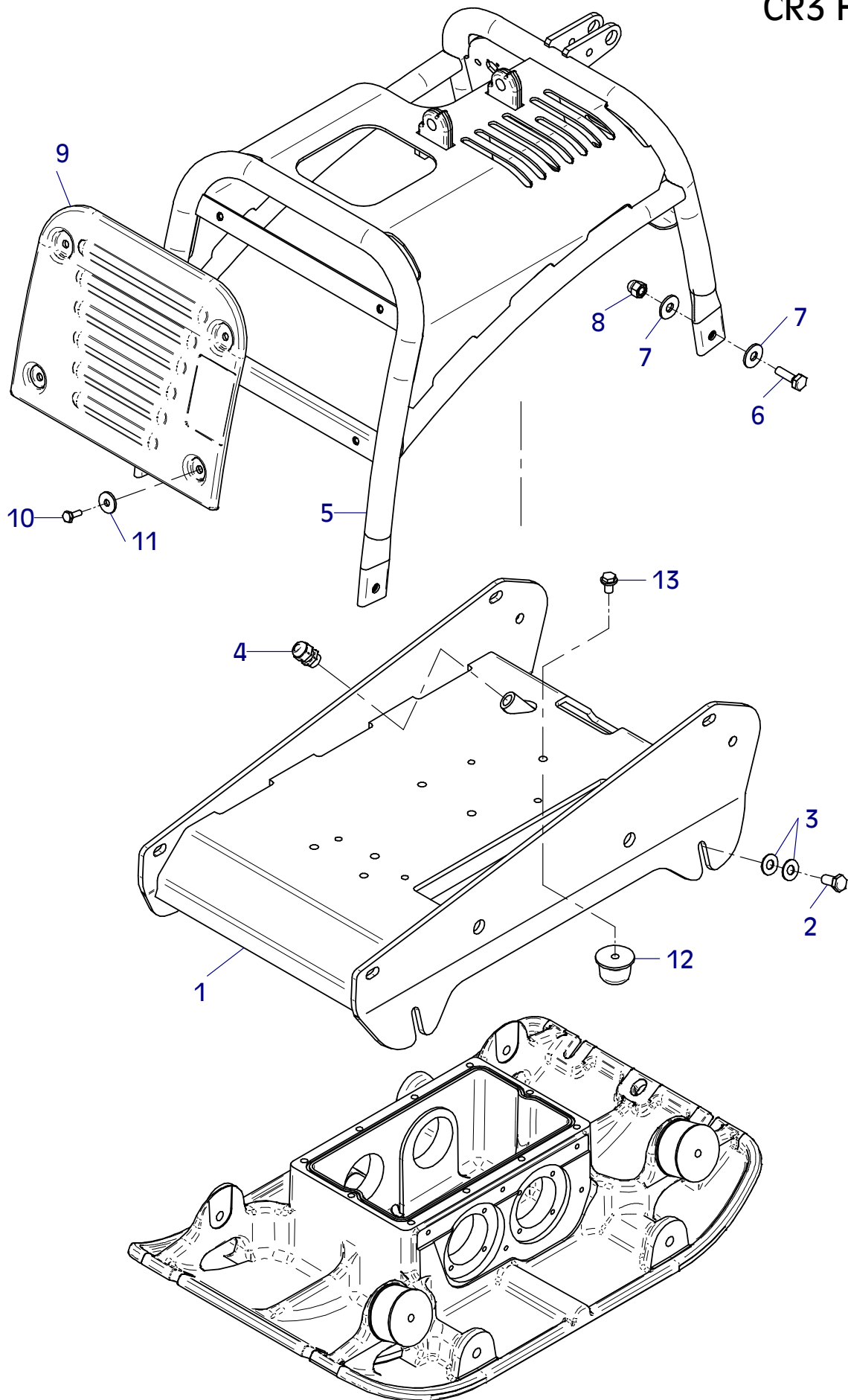

E 3326-0611

## E 3327-0808

Position Ref.No. Repère Posizione Posicion	Menge Quantity Quantité Quantita Cantidad	Teile-Nr. Part-No. No. Référence Nr. d'Ordine No. Referenzia	Hinweis Hints Indications Indicazione Indicaciones	Position Ref. No. Repère Posizione Posicion	Menge Quantity Quantité Quantita Cantidad	Teile-Nr. Part-No. No. Référence Nr. d'Ordine No. Referenzia	Hinweis Hints Indications Indicazione Indicaciones
1	1	10017337					
2	2	21000031					
3	2	11000148					
4	2	25040022	DIN931-M16x70				
5	2	25031017	DIN985-M16				
6	1	11000496					
7	1	25033030	ISO7380-M6x20-10.9				
8	1	25049034	DIN7349-6,4				
9	1	25048001	DIN125-A6,4				
10	1	25031012	DIN985-M6				
11	1	20026481					
12	2	25025191	DIN80705-M20x1,5				
13	2	20025019					
14	1	25040012	DIN931-M10x55				
15	1	25048003	DIN125-A10,5				
16	1	20029001	VSK 10				
17	1	25031004	DIN934-M10				

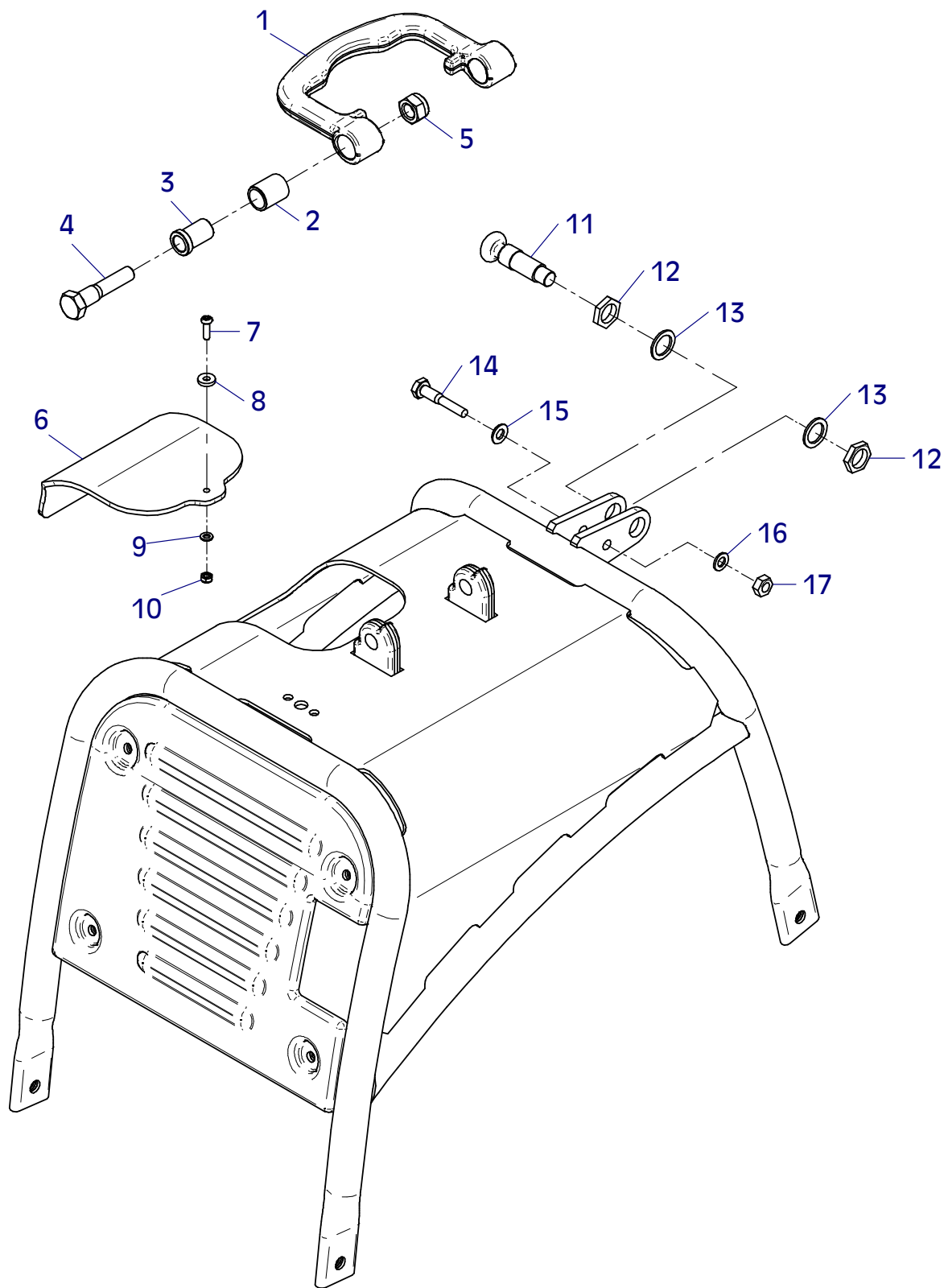

## E 3328-0808

Position Ref.No. Repère Posizione Posicion	Menge Quantity Quantité Quantita Cantidad	Teile-Nr. Part-No. No. Référence Nr. d'Ordine No. Referenzia	Hinweis Hints Indications Indicazione Indicaciones	Position Ref. No. Repère Posizione Posicion	Menge Quantity Quantité Quantita Cantidad	Teile-Nr. Part-No. No. Référence Nr. d'Ordine No. Referenzia	Hinweis Hints Indications Indicazione Indicaciones
1	1	10017337					
2	2	21000031					
3	2	11000148					
4	2	25040022	DIN931-M16x70				
5	2	25031017	DIN985-M16				
6	1	20026481					
7	2	25025191	DIN80705-M20x1,5				
8	2	20025019					
9	1	25040012	DIN931-M10x55				
10	1	25048003	DIN125-A10,5				
11	1	20029001	VSK 10				
12	1	25031004	DIN934-M10				

# CR3 Hd

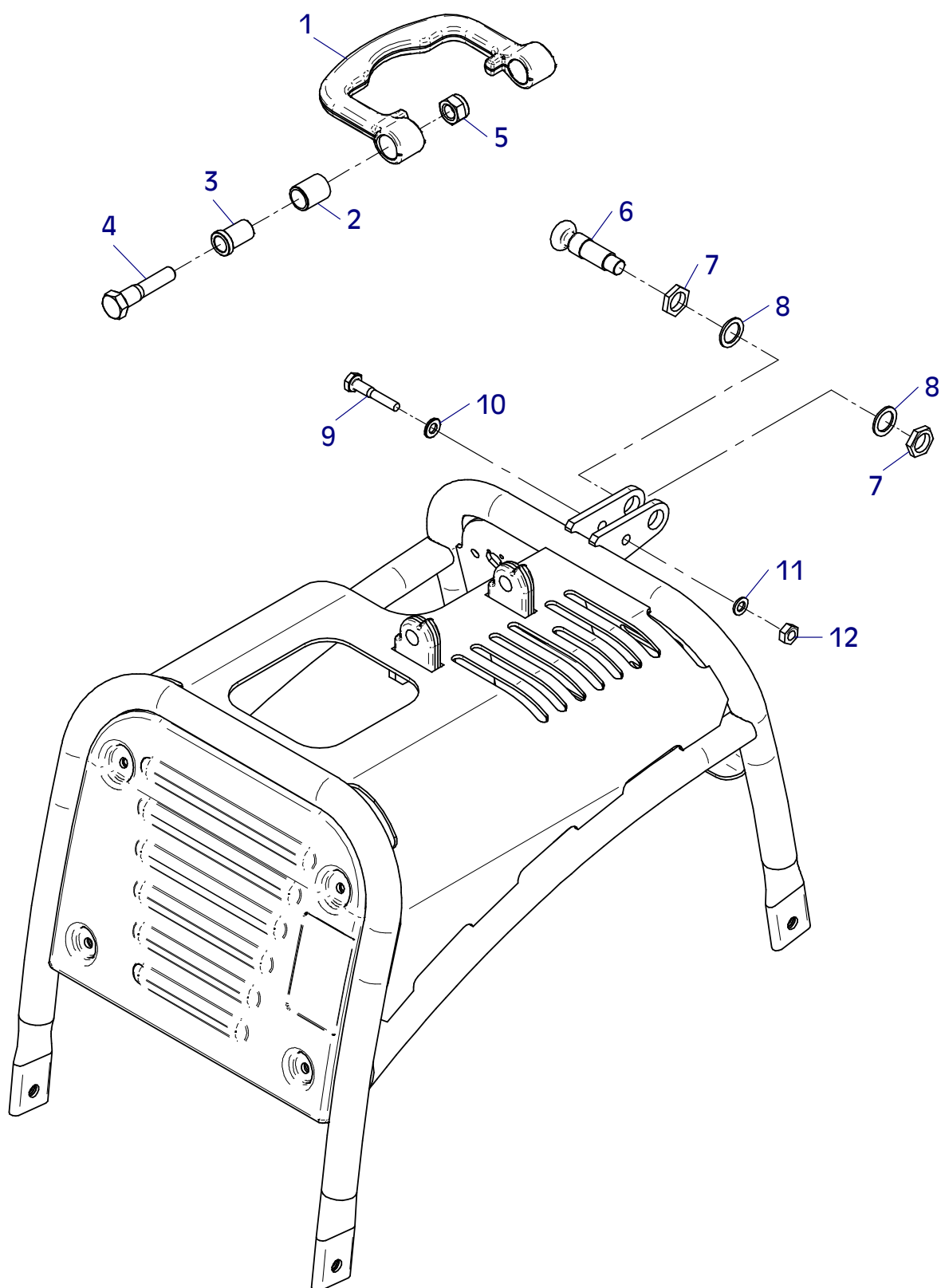

E 3328-0808

## E 3329-0808

Position Ref.No. Repère Posizione Posicion	Menge Quantity Quantité Quantità Cantidad	Teile-Nr. Part-No. No. Référence Nr. d'Ordine No. Referenzia	Hinweis Hints Indications Indicazione Indicaciones	Position Ref. No. Repère Posizione Posicion	Menge Quantity Quantité Quantità Cantidad	Teile-Nr. Part-No. No. Référence Nr. d'Ordine No. Referenzia	Hinweis Hints Indications Indicazione Indicaciones
1	1	21000327					
2	4	25038009	DIN933-M8x30				
3	4	20025122					
4	4	20029024					
5	4	25031003	DIN934-M8				
6	2	25031002	DIN934-M6				
7	2	25048001	DIN125-A6,4				
8	2	20025060					
9	1	40031336					
10	1	40031334					

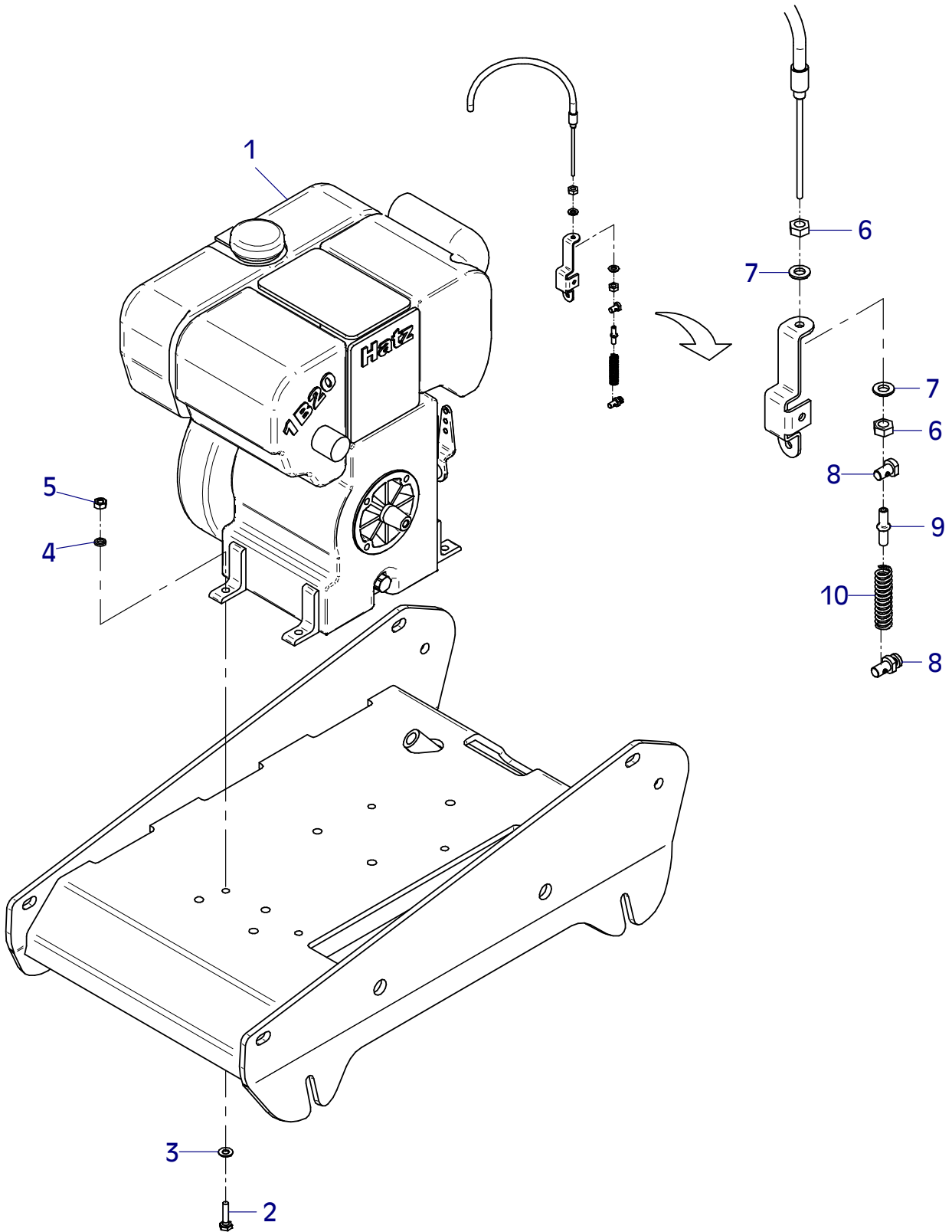

## E 3330-0808

Position Ref.No. Repère Posizione Posicion	Menge Quantity Quantité Quantita Cantidad	Teile-Nr. Part-No. No. Référence Nr. d'Ordine No. Referenzia	Hinweis Hints Indications Indicazione Indicaciones	Position Ref. No. Repère Posizione Posicion	Menge Quantity Quantité Quantita Cantidad	Teile-Nr. Part-No. No. Référence Nr. d'Ordine No. Referenzia	Hinweis Hints Indications Indicazione Indicaciones
1	1	21000328	<b>E</b>				
1	1	21000346	<b>E-EPA</b>				
2	1	25038011	DIN933-M8x40				
3	3	25038009	DIN933-M8x30				
4	4	20025122					
5	4	20029024					
6	4	25031003	DIN934-M8				
7	2	25048002	DIN125-A8,4				
8	1	25031013	DIN985-M8				
9	2	25031002	DIN934-M6				
10	2	25048001	DIN125-A6,4				
11	2	20025060					
12	1	40031336					
13	1	40031334					



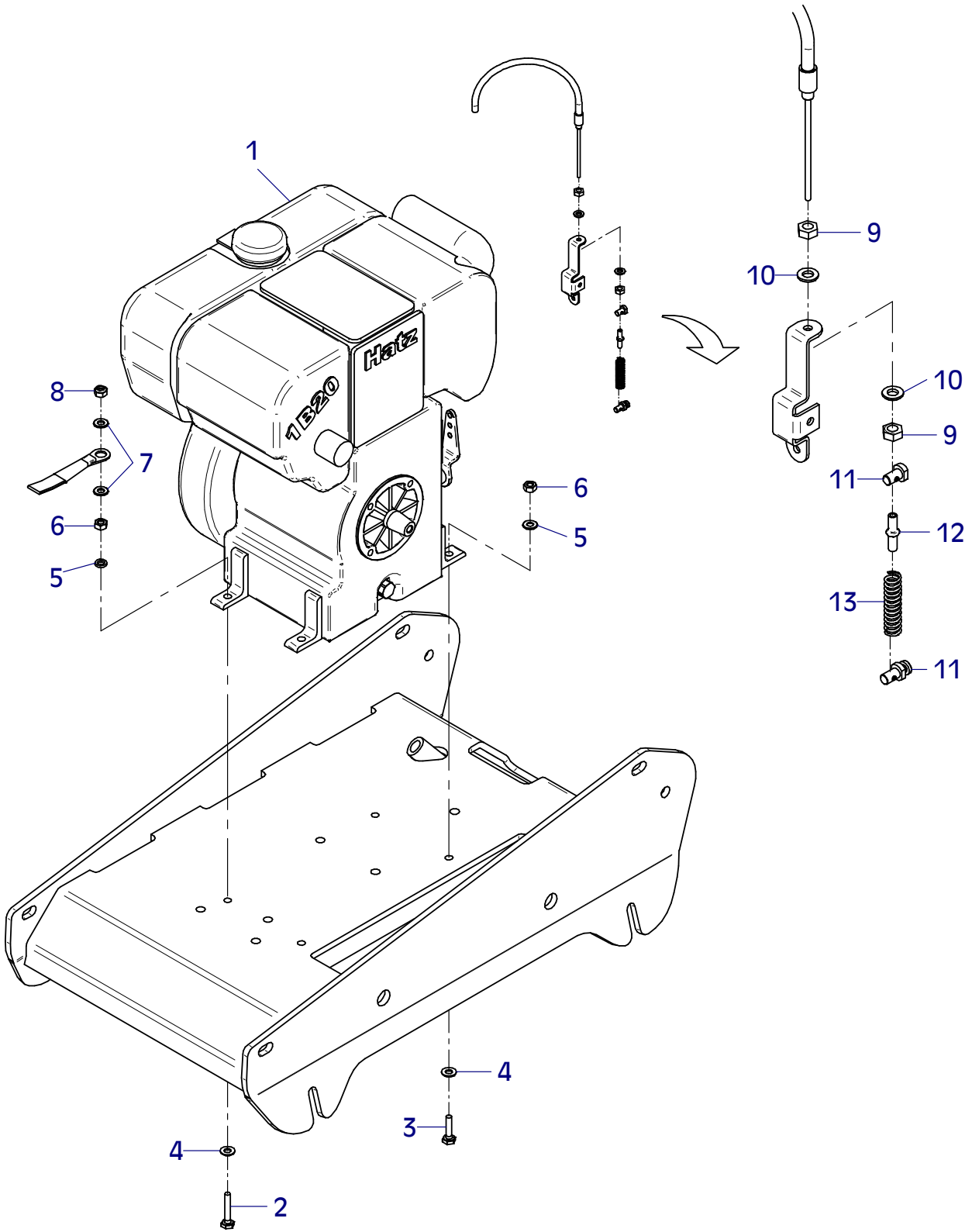

## E 3331-0410

Position Ref.No. Repère Posizione Posicion	Menge Quantity Quantité Quantita Cantidad	Teile-Nr. Part-No. No. Référence Nr. d'Ordine No. Referenzia	Hinweis Hints Indications Indicazione Indicaciones	Position Ref. No. Repère Posizione Posicion	Menge Quantity Quantité Quantita Cantidad	Teile-Nr. Part-No. No. Référence Nr. d'Ordine No. Referenzia	Hinweis Hints Indications Indicazione Indicaciones
1	1	11000545					
2	4	20022013	Tensilock M10x20				
3	1	21000242					
4	1	25002179					
5	1	21000044	DIN912-M8x45-12.9				
6	1	20029003	VSK 8				
7	1	20026475					
8	1	11000944					
9	4	21000585	DIN7964-M8x40				
10	4	20029011	VSKZ 8				
11	1	11000561					
12	1	20007086					
13	1	21000518					
14	1	21000334					
15	1	25008017	DIN7603-22x27x1,5				

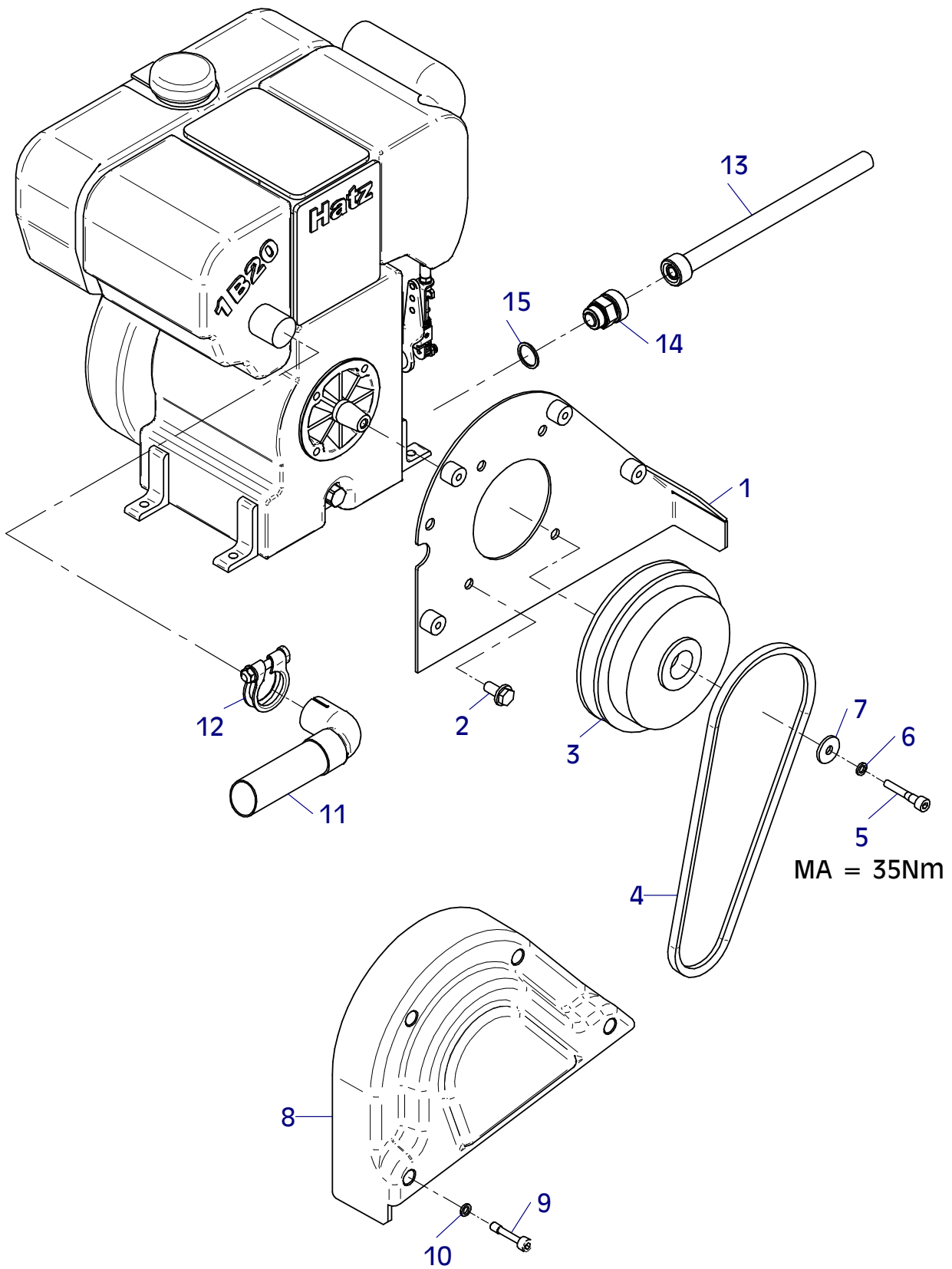

## E 3260-0407

Position Ref.No. Repère Posizione Posicion	Menge Quantity Quantité Quantita Cantidad	Teile-Nr. Part-No. No. Référence Nr. d'Ordine No. Referenzia	Hinweis Hints Indications Indicazione Indicaciones	Position Ref. No. Repère Posizione Posicion	Menge Quantity Quantité Quantita Cantidad	Teile-Nr. Part-No. No. Référence Nr. d'Ordine No. Referenzia	Hinweis Hints Indications Indicazione Indicaciones
1	1	21000242					
2	2	20002548					
3	2	20002269					
4	2	21000151					
5	3	21000019					

# CR3 / CR3 E

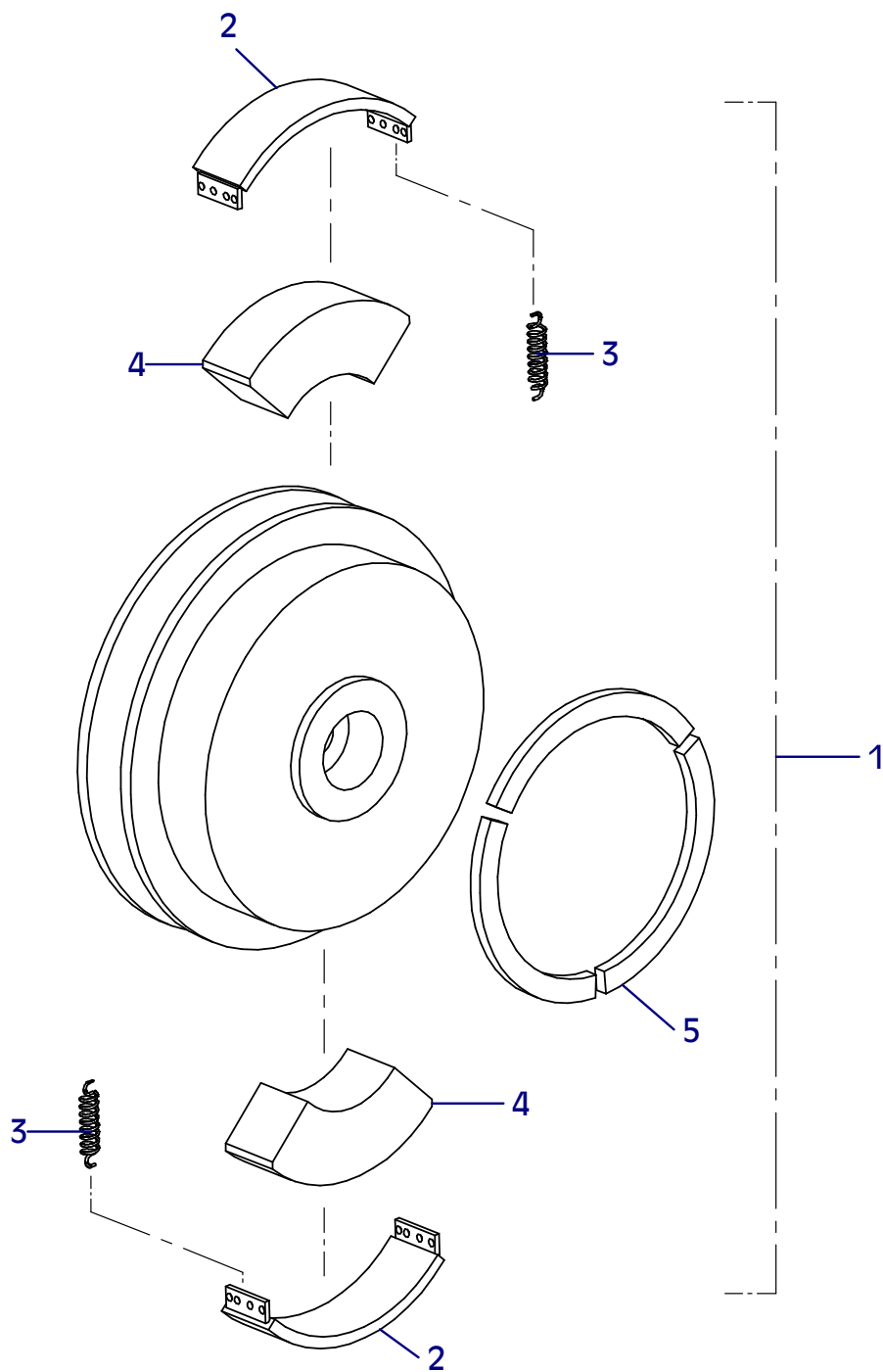

## E 3265-0410

Position Ref.No. Repère Posizione Posicion	Menge Quantity Quantité Quantità Cantidad	Teile-Nr. Part-No. No. Référence Nr. d'Ordine No. Referenzia	Hinweis Hints Indications Indicazione Indicaciones	Position Ref. No. Repère Posizione Posicion	Menge Quantity Quantité Quantità Cantidad	Teile-Nr. Part-No. No. Référence Nr. d'Ordine No. Referenzia	Hinweis Hints Indications Indicazione Indicaciones
1	1	20031558					
2	1	11000597					
3	2	11000596					
4	2	11000595					
5	1	11000594					
6	1	11000627					
7	1	10001457					
8	1	11000470					
9	4	25038006	DIN933-M8x16				
10	4	20029021	SKB 8				
11	1	21000354					
12	1	21000592					
13	1	11000875					
14	2	21000157	ISO7380-M8x20-10.9				
15	2	20025122					
16	1	21000590					
17	4	21000593	DIN85-M5x16				
18	4	25048017	DIN125-A5,3				
19	4	25031023	DIN985-M5				
20	1	20031532					
21	1	11000886					
22	1	20031526					

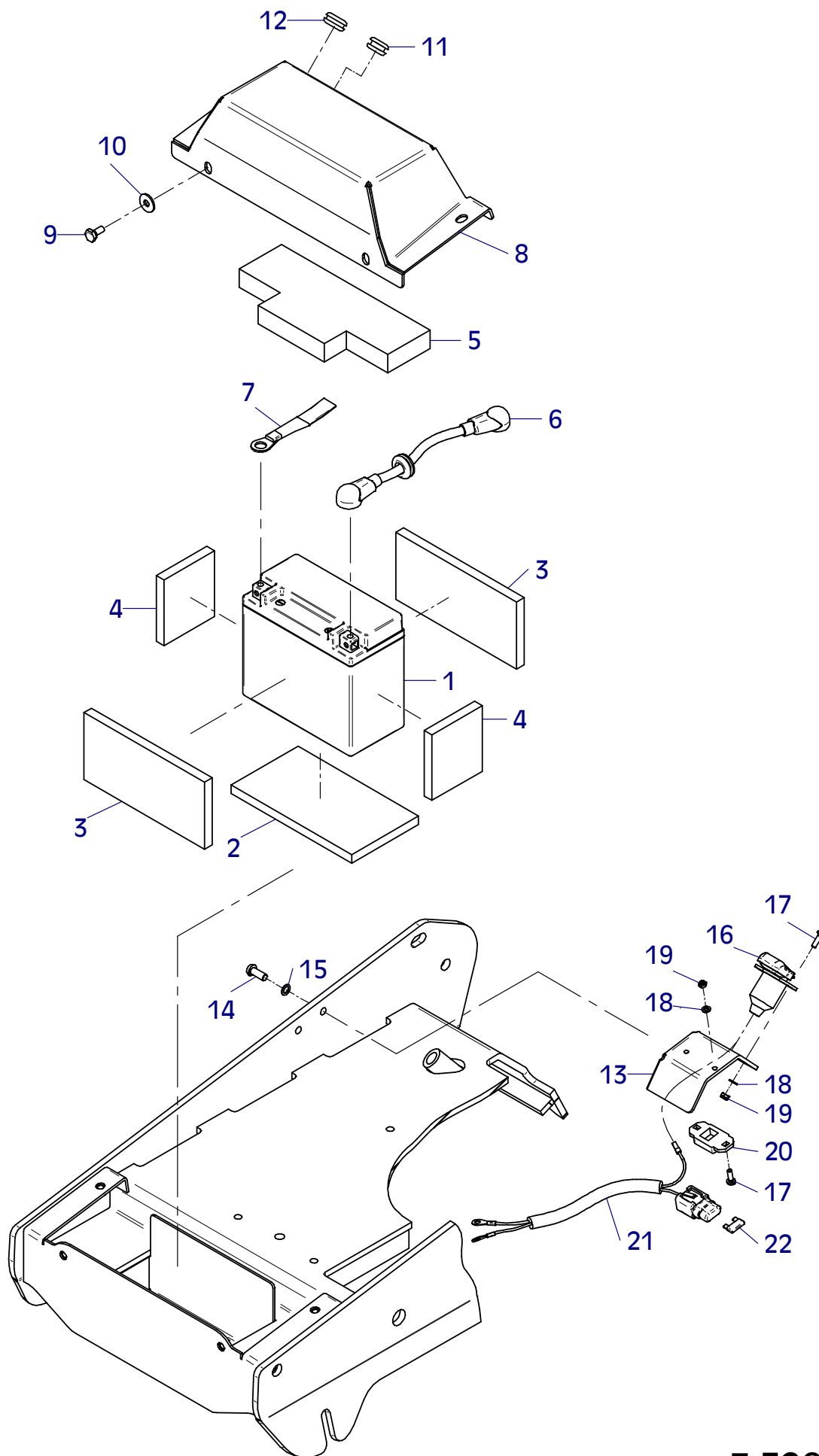

## E 3332-0808

Position Ref.No. Repère Posizione Posicion	Menge Quantity Quantité Quantita Cantidad	Teile-Nr. Part-No. No. Référence Nr. d'Ordine No. Referenzia	Hinweis Hints Indications Indicazione Indicaciones	Position Ref. No. Repère Posizione Posicion	Menge Quantity Quantité Quantita Cantidad	Teile-Nr. Part-No. No. Référence Nr. d'Ordine No. Referenzia	Hinweis Hints Indications Indicazione Indicaciones
1	1	20001230					
2	2	10016212					
3	4	25040012	DIN931-M10x55				
4	4	20025287					
5	4	20029025					
6	4	25031004	DIN934-M10				
7	1	20026580					
8	1	20007007					
9	1	25038002	DIN933-M6x16				
10	1	20029007	VSK 6				
11	1	25048001	DIN125-A6,4				
12	1	20026384					
13	2	20026389					
14	1	21000335					
15	1	20026383					



CR 3 Hd

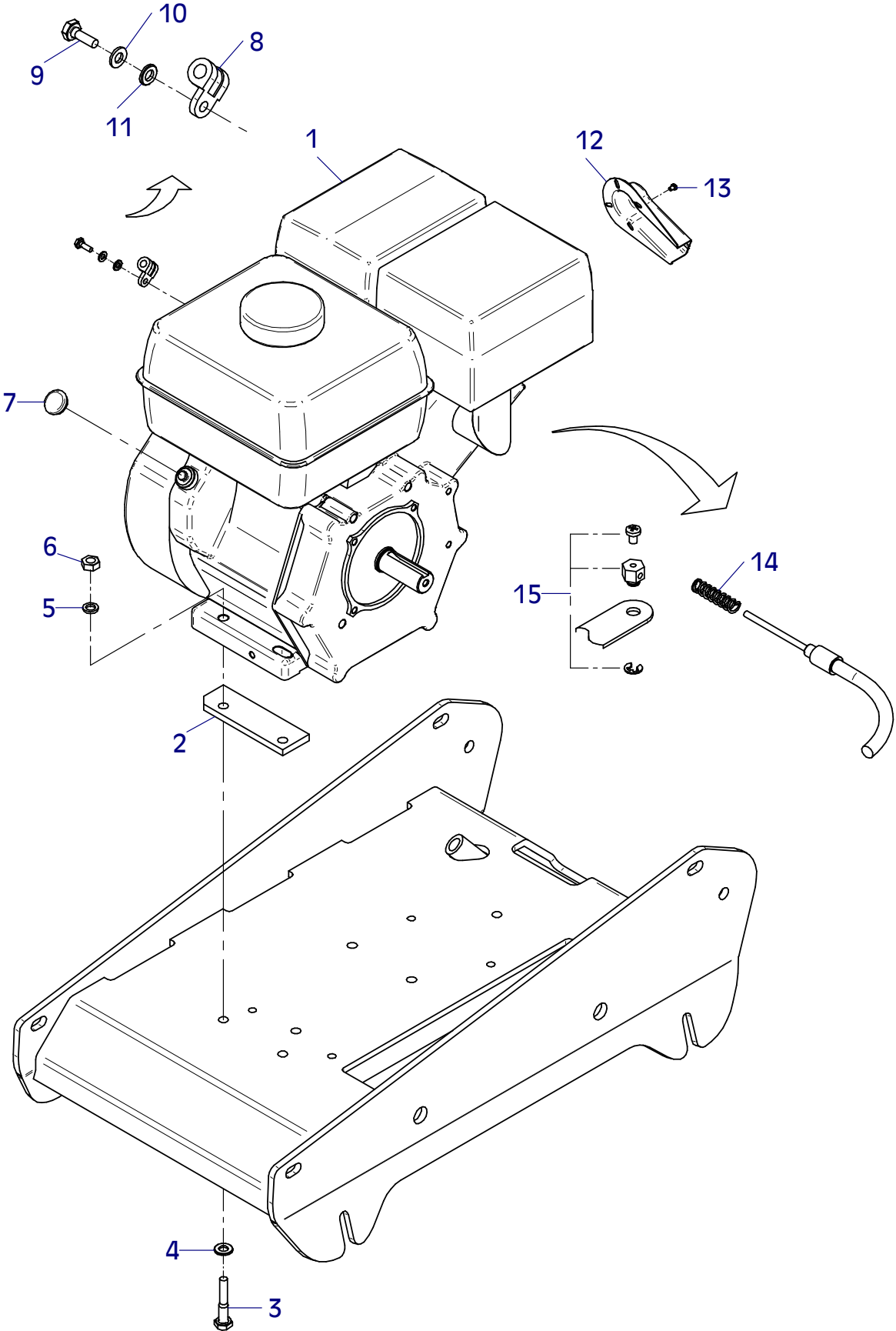

## E 3333-0611

Position Ref.No. Repère Posizione Posicion	Menge Quantity Quantité Quantita Cantidad	Teile-Nr. Part-No. No. Référence Nr. d'Ordine No. Referenzia	Hinweis Hints Indications Indicazione Indicaciones	Position Ref. No. Repère Posizione Posicion	Menge Quantity Quantité Quantita Cantidad	Teile-Nr. Part-No. No. Référence Nr. d'Ordine No. Referenzia	Hinweis Hints Indications Indicazione Indicaciones
1	1	11000635					
2	1	25038008	DIN933-M8x25				
3	1	25048002	DIN125-A8,4				
4	1	20022002	Tensilock M8				
5	1	25038007	DIN933-M8x20				
6	1	25048002	DIN125-A8,4				
7	1	20022002	Tensilock M8				
8	1	11000576					
9	1	25038006	DIN933-M8x16				
10	2	25048002	DIN125-A8,4				
11	1	25031003	DIN934-M8				
12	1	11001155					
13	1	21000224	DIN912-M4x16				
14	1	25048023	DIN125-B4,3				
15	1	21000571					
16	1	21000220	DIN9021-4,3				
17	1	25031011	DIN985-M4				
18	1	21000686	DIN7981-ST2,9x9,5				
19	1	25048029	DIN125-B3,2				

CR3 Hd

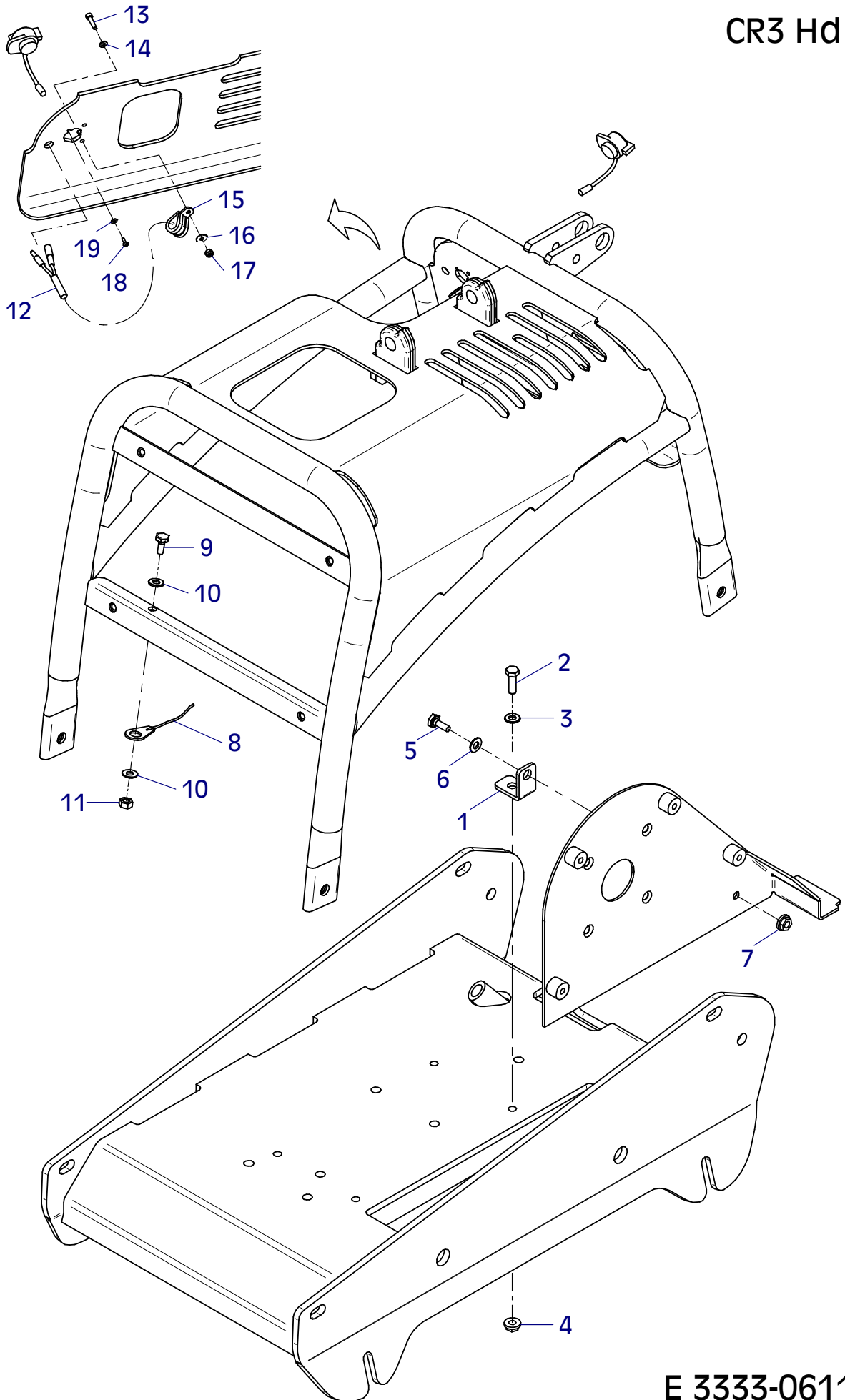

E 3333-0611

## E 3334-0410

Position Ref.No. Repère Posizione Posicion	Menge Quantity Quantité Quantita Cantidad	Teile-Nr. Part-No. No. Référence Nr. d'Ordine No. Referenzia	Hinweis Hints Indications Indicazione Indicaciones	Position Ref. No. Repère Posizione Posicion	Menge Quantity Quantité Quantita Cantidad	Teile-Nr. Part-No. No. Référence Nr. d'Ordine No. Referenzia	Hinweis Hints Indications Indicazione Indicaciones
1	1	11000547					
2	4	25047017	DIN7991-M8x20				
3	4	25005003	DIN6798-V8,4				
4	1	21000323					
5	1	10016954					
6	1	21000653					
7	1	25044501	DIN912-M8x30-10.9				
8	1	20029011	VSKZ 8				
9	1	11000593					
10	1	11000944					
11	4	21000585	DIN7964-M8x40				
12	4	20029011	VSKZ 8				
13	1	21000518					
14	1	20026204					
15	1	25008011	DIN7603-12x18x1,5				

# CR3 Hd

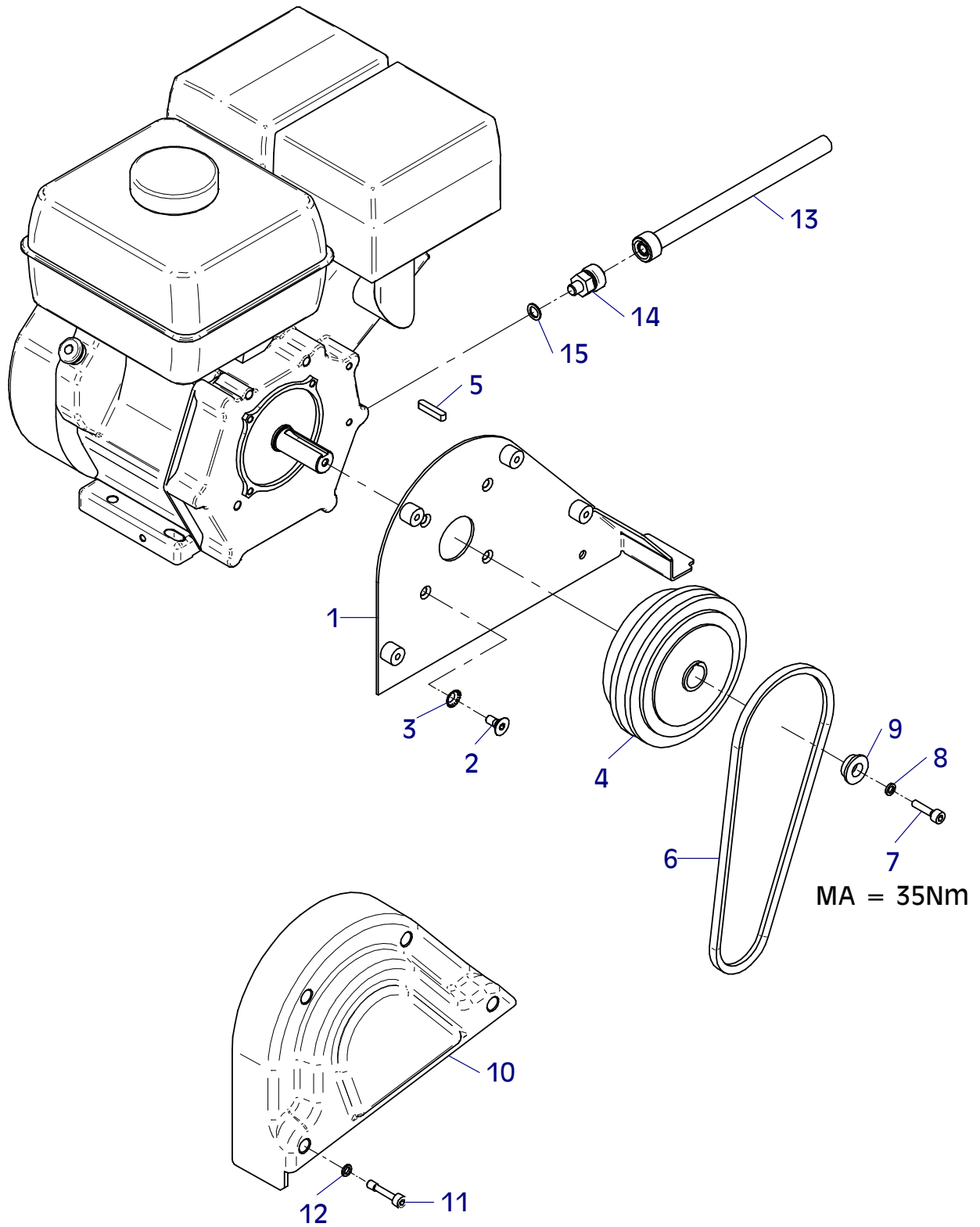

E 3334-0410

## E 3267-0907

Position Ref.No. Repère Posizione Posicion	Menge Quantity Quantité Quantita Cantidad	Teile-Nr. Part-No. No. Référence Nr. d'Ordine No. Referenzia	Hinweis Hints Indications Indicazione Indicaciones	Position Ref. No. Repère Posizione Posicion	Menge Quantity Quantité Quantita Cantidad	Teile-Nr. Part-No. No. Référence Nr. d'Ordine No. Referenzia	Hinweis Hints Indications Indicazione Indicaciones
1	1	21000323					
2	2	20002548					
3	2	20002269					
4	2	21000151					
5	3	21000357					

# CR3 Hd

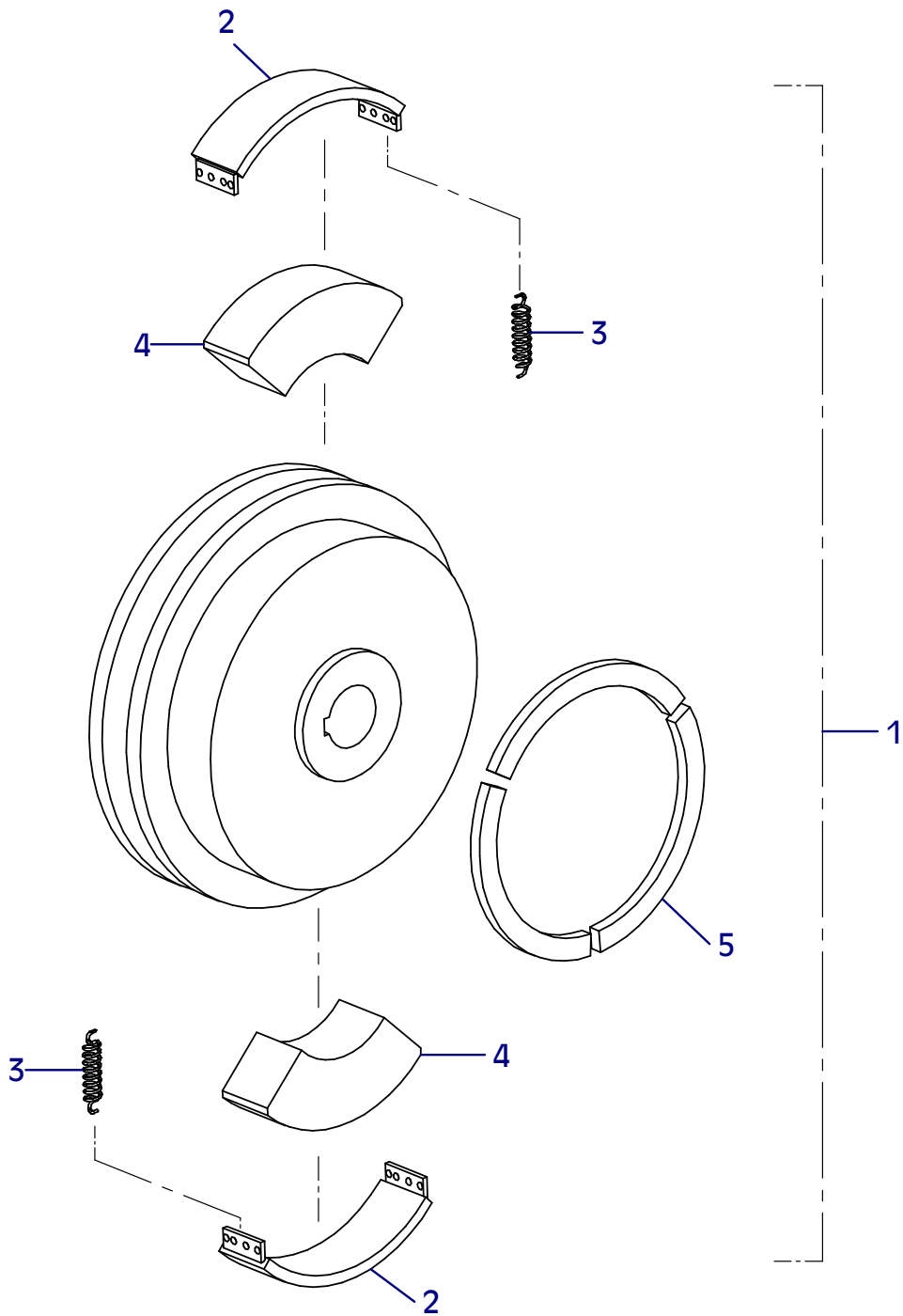

## E 3335-0808

Position Ref.No. Repère Posizione Posicion	Menge Quantity Quantité Quantita Cantidad	Teile-Nr. Part-No. No. Référence Nr. d'Ordine No. Referenzia	Hinweis Hints Indications Indicazione Indicaciones	Position Ref. No. Repère Posizione Posicion	Menge Quantity Quantité Quantita Cantidad	Teile-Nr. Part-No. No. Référence Nr. d'Ordine No. Referenzia	Hinweis Hints Indications Indicazione Indicaciones
1	1	11000460					
2	2	10016876					
3	4	25044046	DIN912-M8x55				
4	4	20029011	VSKZ 8				
5	2	20026493					
6	2	10016877					
7	2	25040033	DIN931-M12x70				
8	2	20029004	VSK 12				
9	2	25048004	DIN125-A13				
10	2	20026546					
11	2	20004061					
12	2	25038018	DIN933-M12x20				
13	2	20029023	SKB 12				
14	1	11000567					
15	2	20005019					
16	2	25031004	DIN934-M10				
17	1	21000261					
18	1	20007202					



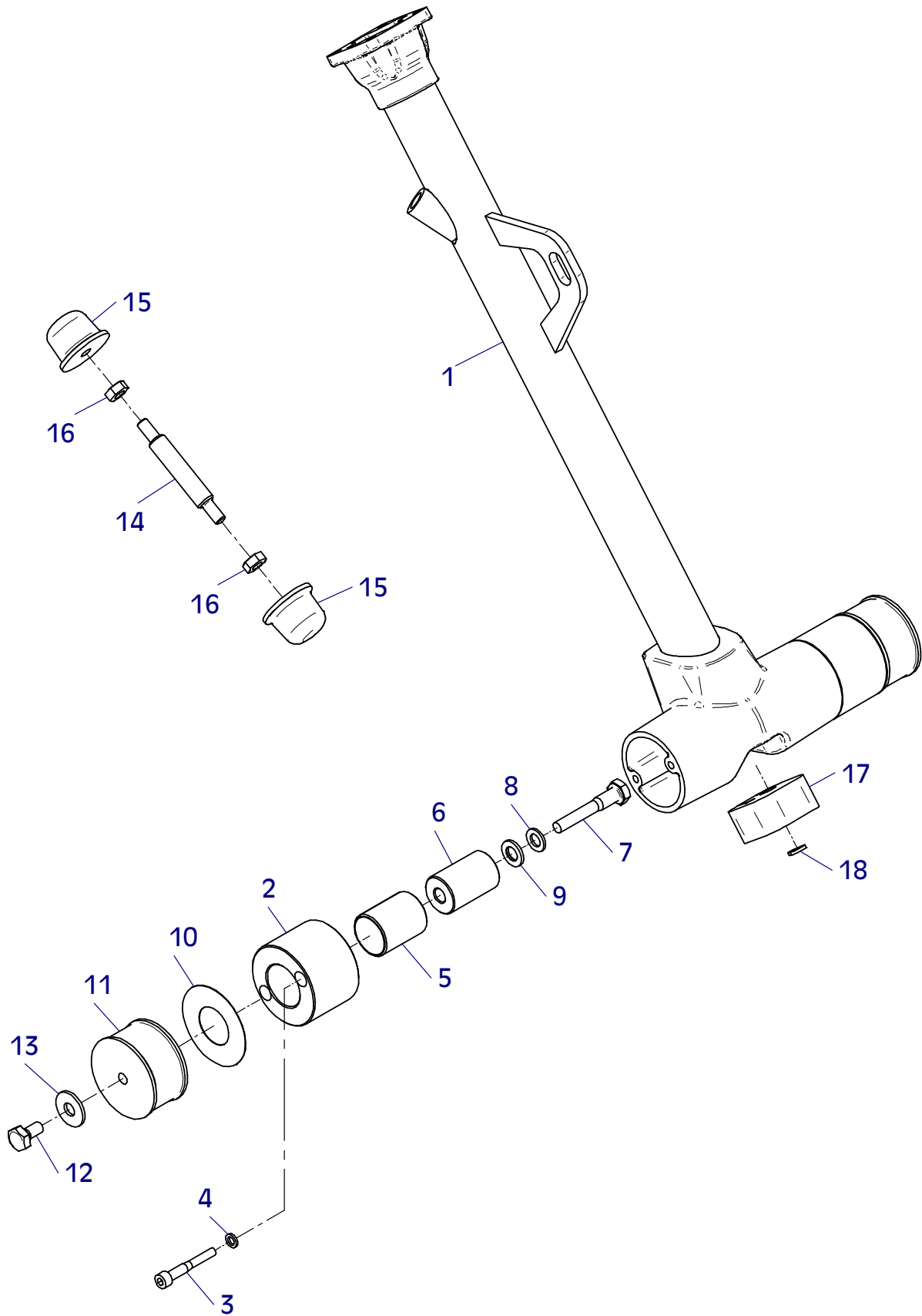

E 3335-0808

## E 3336-0410

Position Ref.No. Repère Posizione Posicion	Menge Quantity Quantité Quantita Cantidad	Teile-Nr. Part-No. No. Référence Nr. d'Ordine No. Referenzia	Hinweis Hints Indications Indicazione Indicaciones	Position Ref. No. Repère Posizione Posicion	Menge Quantity Quantité Quantita Cantidad	Teile-Nr. Part-No. No. Référence Nr. d'Ordine No. Referenzia	Hinweis Hints Indications Indicazione Indicaciones
1	1	11000455					
2	4	25044006	DIN912-M8x25				
3	4	20029011	VSKZ 8				
4	1	20008067					
5	1	11000456					
6	1	20013282					
7	1	11000457					
8	1	20013284					
9	1	25035027	DIN472-I58x2				
10	1	20020119					
11	1	21000324					
12	1	21000253	<b>Hatz</b>				
12	1	21000349	<b>Honda</b>				
13	2	21000258	DIN933-M5x30				
14	2	20029006	VSK 5				
15	1	25009021					
16	1	25030002	DIN908-M14x1,5				
17	1	21000256					
18	1	25030003	DIN908-M24x1,5				
19	1	25008008	DIN7603-24x32x2				
20	1	21000488					

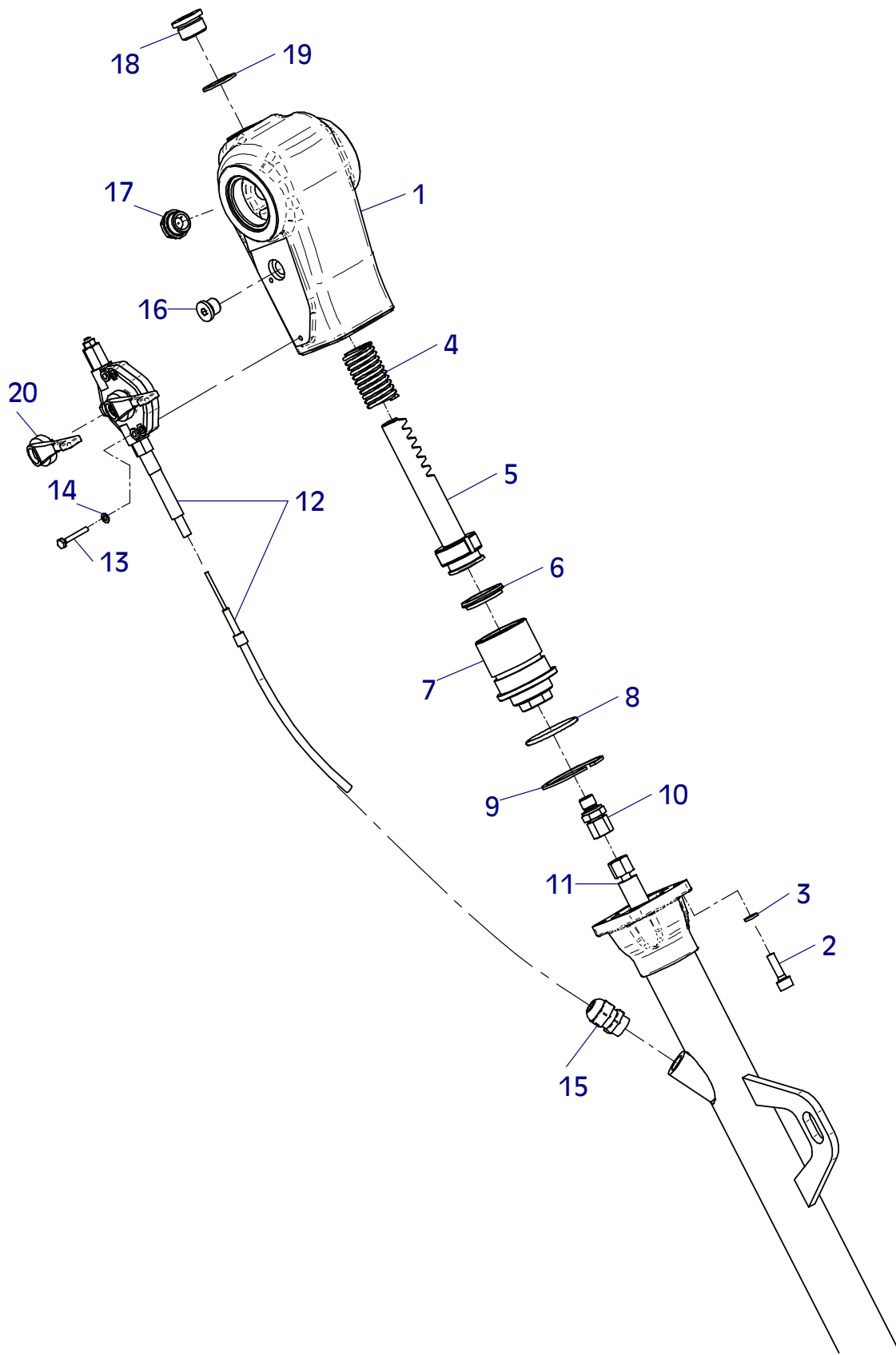

E 3336-0410

## E 3337-0808

Position Ref.No. Repère Posizione Posicion	Menge Quantity Quantité Quantita Cantidad	Teile-Nr. Part-No. No. Référence Nr. d'Ordine No. Referenzia	Hinweis Hints Indications Indicazione Indicaciones	Position Ref. No. Repère Posizione Posicion	Menge Quantity Quantité Quantita Cantidad	Teile-Nr. Part-No. No. Référence Nr. d'Ordine No. Referenzia	Hinweis Hints Indications Indicazione Indicaciones
1	1	10017394					
2	2	10017397					
3	2	20013271					
4	2	25017048					
5	2	10017396					
6	2	25044035	DIN912-M12x25				
7	2	20025158					
8	2	11000056					
9	1	11000038					
10	4	25038008	DIN933-M8x25				
11	4	20029003	VSK 8				
12	2	20025593					

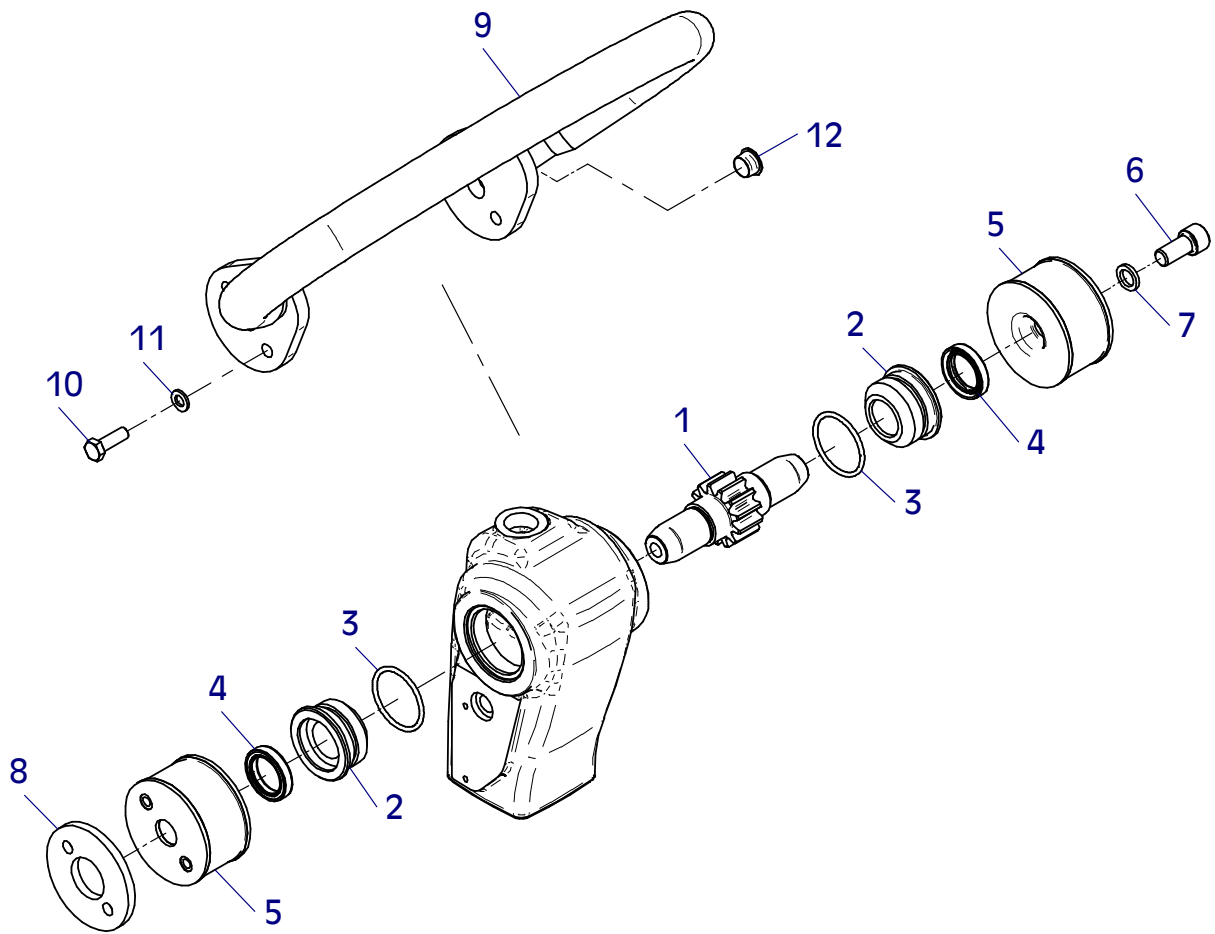

E 3337-0808

## E 3266-0208

Position Ref.No. Repère Posizione Posicion	Menge Quantity Quantité Quantita Cantidad	Teile-Nr. Part-No. No. Référence Nr. d'Ordine No. Referenzia	Hinweis Hints Indications Indicazione Indicaciones	Position Ref. No. Repère Posizione Posicion	Menge Quantity Quantité Quantita Cantidad	Teile-Nr. Part-No. No. Référence Nr. d'Ordine No. Referenzia	Hinweis Hints Indications Indicazione Indicaciones
1	2	11000338					
2	4	25038046	DIN933-M16x50-10.9				
3	4	20029029					
4							
5							
6							
7							
8							
9							
10	2	11000615					
11	4	25038046	DIN933-M16x50-10.9				
12	4	20029029					

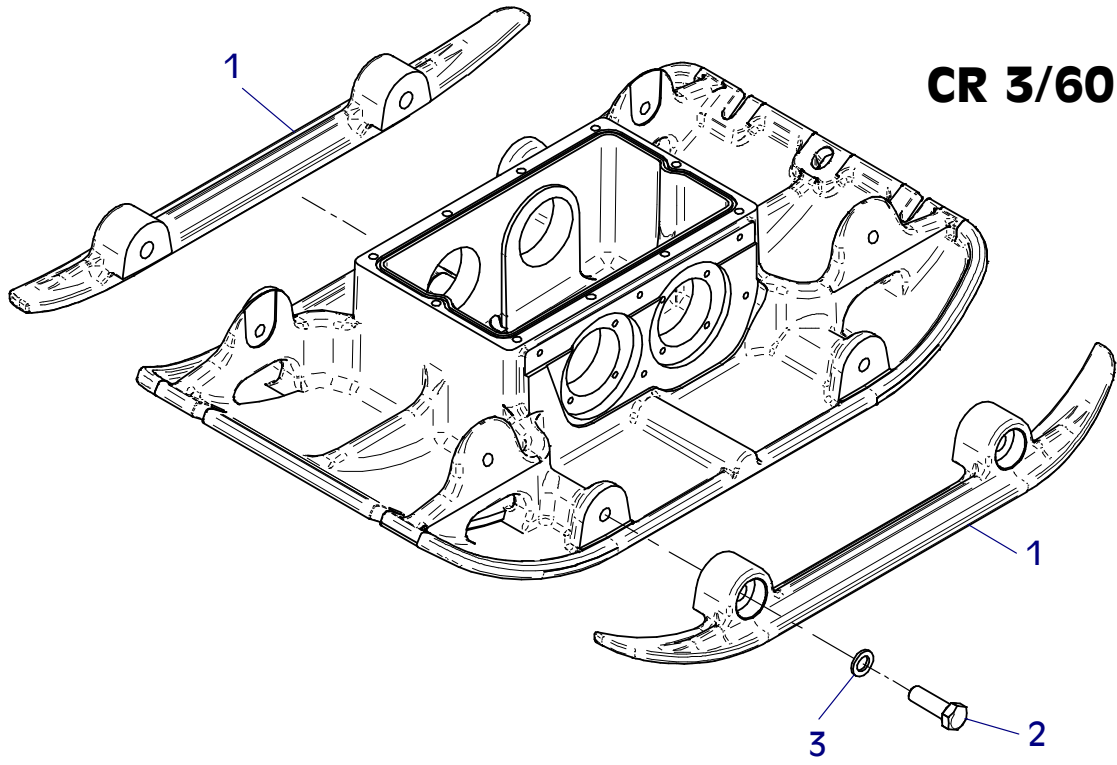

**CR 3/60**

MA = 310Nm

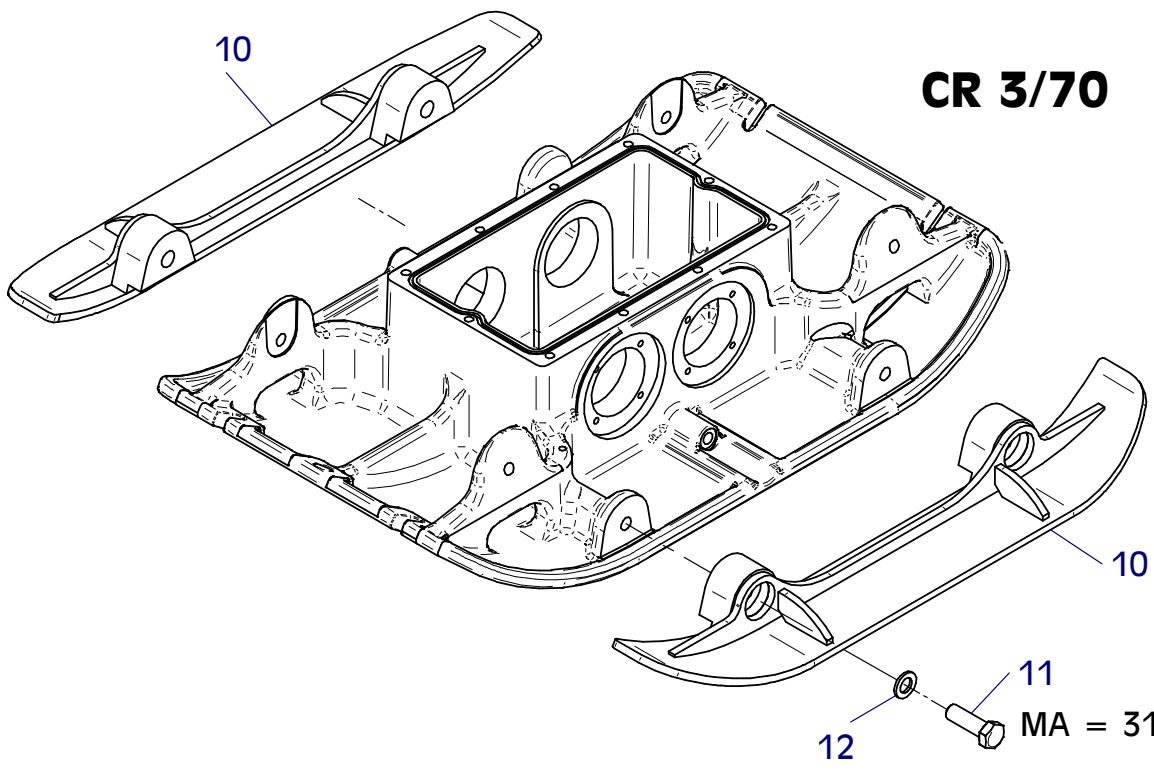

**CR 3/70**

MA = 310Nm

E 3266-0208

## E 3290-1207

Position Ref.No. Repère Posizione Posicion	Menge Quantity Quantité Cantidad	Teile-Nr. Part-No. No. Référence Nr. d'Ordine No. Referenzia	Hinweis Hints Indications Indicazione Indicaciones	Position Ref. No. Repère Posizione Posicion	Menge Quantity Quantité Cantidad	Teile-Nr. Part-No. No. Référence Nr. d'Ordine No. Referenzia	Hinweis Hints Indications Indicazione Indicaciones
1	1	11000610					
2	2	11000612					
3	4	25040019	DIN931-M12x55				
4	4	25048004	DIN125-A13				
5	4	20029023	SKB 12				
6	4	25031005	DIN934-M12				
7							
8							
9							
10	1	11000611	<b>CR 3/60</b>				
10	1	11000631	<b>CR 3/70</b>				
11	2	11000612					
12	4	25040019	DIN931-M12x55				
13	4	25048004	DIN125-A13				
14	4	20029023	SKB 12				
15	4	25031005	DIN934-M12				



**CR 3**

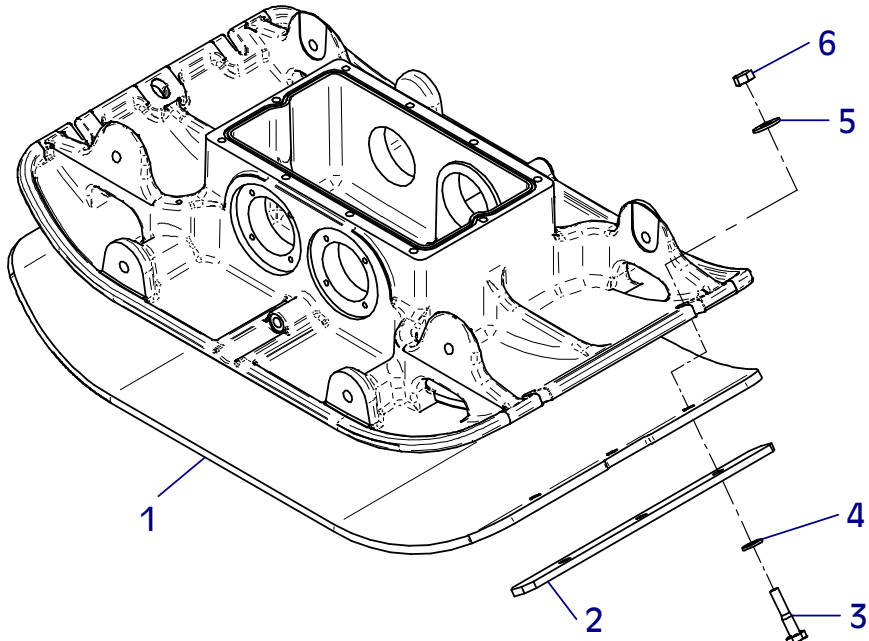

**CR 3/60**  
**CR 3/70**

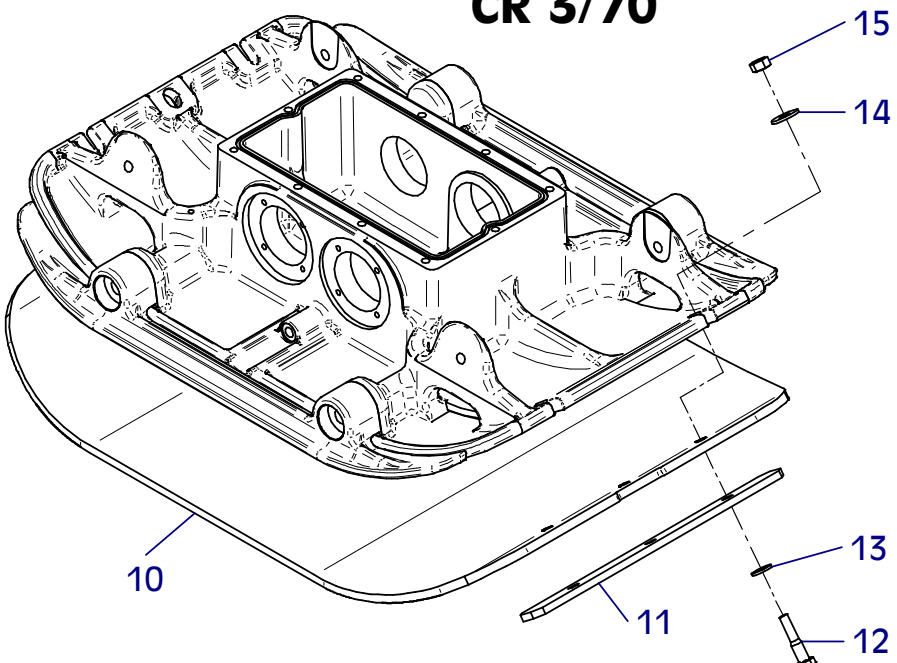

## E 3031-0808

Position Ref.No. Repère Posizione Posicion	Menge Quantity Quantité Quantita Cantidad	Teile-Nr. Part-No. No. Référence Nr. d'Ordine No. Referenzia	Hinweis Hints Indications Indicazione Indicaciones	Position Ref. No. Repère Posizione Posicion	Menge Quantity Quantité Quantita Cantidad	Teile-Nr. Part-No. No. Référence Nr. d'Ordine No. Referenzia	Hinweis Hints Indications Indicazione Indicaciones
1	1	10022502	<b>CR3 , CR4</b>				
1	1	10022504	<b>CR3/60 , CR4/65</b>				
1	1	11000639	<b>CR3/70</b>				
2	1	10016239					
3	1	20025508					
4	1	25031004	DIN934-M10				
5	1	25038060	DIN933-M10x50				
6	2	20025007					
7	4	25048006	DIN125-A21				
8	2	25037002					
9	1	10022503					
10	1	25040018	DIN931-M12x50				
11	1	25048004	DIN125-A13 - <b>CR4</b>				
11	1	25049011	DIN7349-13x30x6 - <b>CR3</b>				
12	1	20029023	SKB 12				
13	1	25031005	DIN934-M12				

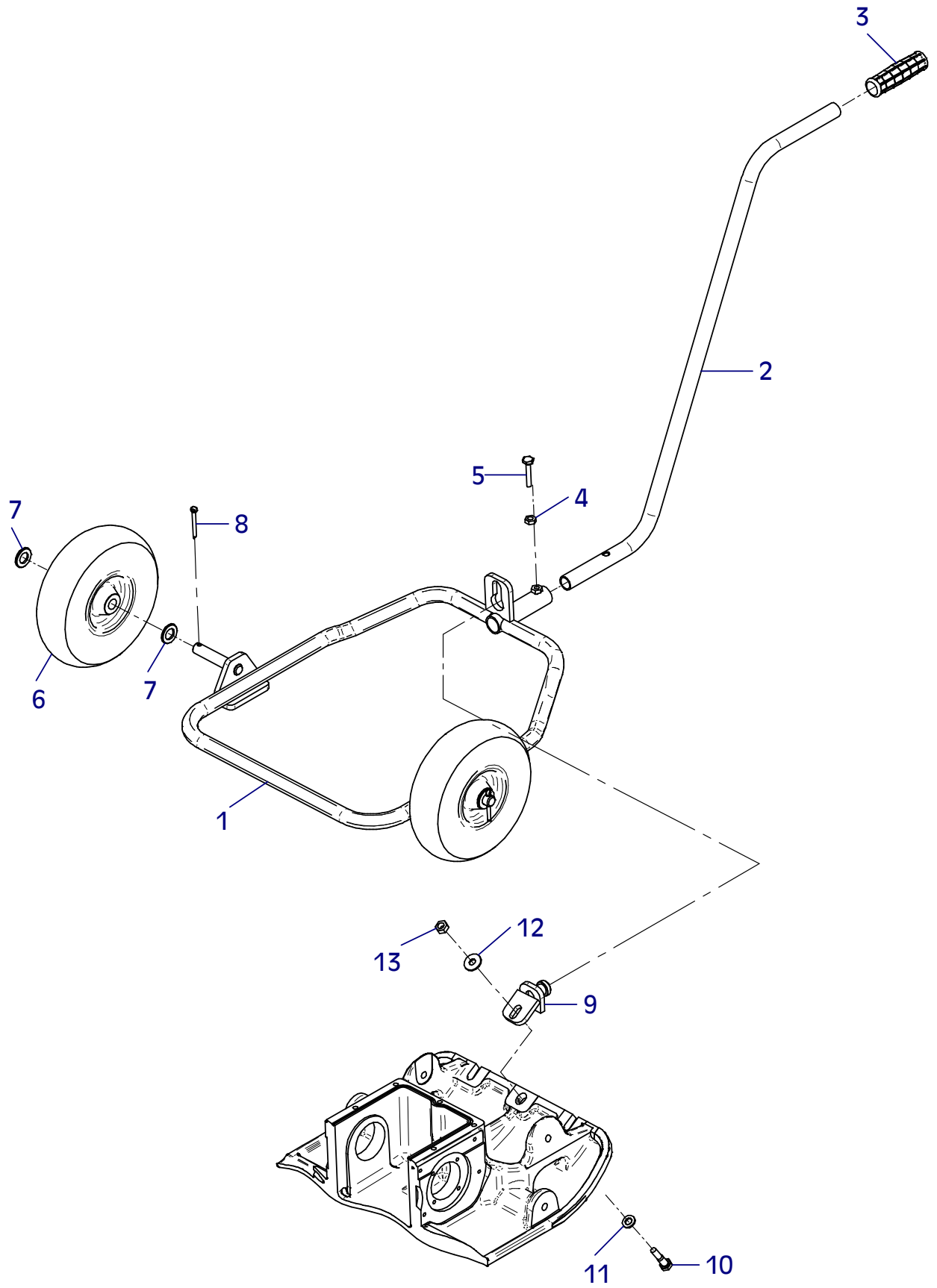

E 3031-0808

## E 3410-0410

Position Ref.No. Repère Posizione Posicion	Menge Quantity Quantité Quantita Cantidad	Teile-Nr. Part-No. No. Référence Nr. d'Ordine No. Referenzia	Hinweis Hints Indications Indicazione Indicaciones	Position Ref. No. Repère Posizione Posicion	Menge Quantity Quantité Quantita Cantidad	Teile-Nr. Part-No. No. Référence Nr. d'Ordine No. Referenzia	Hinweis Hints Indications Indicazione Indicaciones
1	1	21000603					
2	1	11000887					





Wenn Sie Fragen, Anregungen, Probleme, usw. haben, wenden Sie sich bitte an eine der unten genannten Adressen:

For problems, questions and further information refer to one of the following addresses:

Si des questions, des suggestions, des problèmes ... survenaient, veuillez vous adresser a l'une des adresses - ci dessous

<p>in Deutschland</p> <p>in Germany</p> <p>Pour l' Allemagne</p>	<p>WEBER Maschinentechnik GmbH 57334 Bad Laasphe – Rückershausen Im Boden 5-8, 10</p>	<p>Telefon + 49 (0) 2754 - 398-0 Telefax + 49 (0) 2754 - 398101-Zentrale switchboard Central + 49 (0) 2754 - 398102-Ersatzteil-Direktlinie spare parts-directlinie Ligne direct pièces détachées</p> <p>E-Mail <a href="mailto:g.voelkel@webermt.de">g.voelkel@webermt.de</a></p>
<p>in Frankreich</p> <p>in France</p> <p>Pour la France</p>	<p>WEBER Technologie SARL 26' rue d' Arsonval 69680 Chassieu</p>	<p>Telefon + 33 (0) 472 - 791020 Telefax + 33 (0) 472 - 791021</p> <p>E-Mail <a href="mailto:france@webermt.com">france@webermt.com</a></p>
<p>in Polen</p> <p>in Poland</p> <p>Pour la Pologne</p>	<p>WEBER Maschinentechnik Sp. zo.o. Ul. Grodziska 7 05-830 Stara Wies</p>	<p>Telefon + 48 (0) 22 - 739 70 - 80 Telefax + 48 (0) 22 - 739 70 - 81 + 48 (0) 22 - 739 70 - 82</p> <p>E-Mail <a href="mailto:info@webermt.com.pl">info@webermt.com.pl</a></p>
<p>in Tschechien</p> <p>in Czechia</p> <p>Pour la Tchéquie</p>	<p>WEBER MT s.r.o. V Piskovně (areál 5H) Kralupy nad Vítavou 278 01</p>	<p>Telefon + 42 (0) 776 222 216 + 42 (0) 776 222 261</p> <p>E-Mail <a href="mailto:info@webermt.cz">info@webermt.cz</a></p>
<p>in USA und Kanada</p> <p>in USA and Canada</p> <p>Pour les Etats Unis Et le Canada</p>	<p>WEBER MT, Inc. 45 Dowd Road Bangor, ME 04401</p>	<p>Telefon + 1(207) - 947 - 4990 Telefax + 1(207) - 947 - 5452</p> <p>E-Mail <a href="mailto:sales@webermt.com">sales@webermt.com</a> <a href="mailto:service@webermt.com">service@webermt.com</a></p>
<p>in Süd – Amerika</p> <p>in South – America</p> <p>Pour l' Amérique du sud</p>	<p>WEBER Maschinentechnik do Brasil Máquinas Para Construção Ltda. Rua Curt Wacker, n° 45 93332 – 200 Novo Hamburgo, RS Brasil</p>	<p>Telefon + 55 (0) 51- 587 3044 Telefax + 55 (0) 51- 587 2271</p> <p>E-Mail <a href="mailto:webermt@webermt.com.br">webermt@webermt.com.br</a></p>

