



ERSATZTEILLISTE

SPARE PARTS LIST

**LISTE DES PIECES
DE RECHANGE**

LISTINO RICAMBI

LISTA DE RECAMBIOS

**WYKAZ CZESCI
ZAMIENNYCH**



CR 5
CR 5/70

011631-011636



Weber Maschinenteknik GmbH
Postfach 2153, 57329 Bad Laasphe-Rückershausen
Telefon 02754 / 398-0
Telefax (02754) 398-101 (Zentrale) u. 398-102 (Ersatzteile)

EG - KONFORMITÄTSERKLÄRUNG

EC DECLARATION OF CONFORMITY/ DECLARATION DE CONFORMITE CE
DICHIARAZIONE CE DI CONFORMITA / DECLARACION CE DE CONFORMIDAD
EG-VERKLARING VAN OVEREENSTEMMING / EF-OVERENSSTEMMELSESERKAERING
DECLARACAO CE DE CONFORMIDADE / EG-FÖRSÄKRAN OM ÖVERENSSTÄMMELSE
DEKLARACJA ZGODNOŚCI

im Sinne der EG-Maschinenrichtlinie 98/37/EG und der EG Richtlinie 2000/14/EG - Geräuschemissionen

- I **Art / Category / Catégorie / Categoria Tipo / Kategori / Soort / Categoria / kategori / Typ**
- II **Hersteller (Typ) / Make (Type) / Marque (Type) / Marca (Tipo) / Marca (Codice) / Producent (Type) / Merk (Type) / Marca (Tipo) / Tillverkare (Typ) / Producent**
- III **Nennleistung / Nominal-performance / La puissance nominale / Prestazione nominale / Potencia nominal / Nominaal vermogen / Nominel ydelse / Potência nominal / Nominell effect / Moc**
- IV **gemessener Schalleistungspegel / measured sound power level / niveau de puissance acoustique mesure / livello di potenza sonora rilevato / nivel de potencia acústica medido / gemeten geluidsvermogensniveau / målt lydeffektniveau / Nivel de potência sonora midido / uppmätt ljudeffektnivå / Mierzony poziom dźwięku**
- V **garantierter Schalleistungspegel / guaranteed sound power level / niveau de puissance acoustique garanti / livello di potenza sonora garantito / nivel de potencia acústica garantizado / gwaarborgd geluidsvermogensniveau / garanteret lydeffektniveau / Nivel sonoro garantido / garanterad ljudeffektnivå / Natężenie hałasu**
- VI **beteiligte Zertifizierungsstelle / notified body involved / de l'organisme notifié/ dell'organismo notificato che l'ha effettuata / dirección del organismo notificado que haya intervenido / betrokken aangemelde instantie / pågældende bemyndigede organ / organismo notificado involucrado / berörda anmälda organets namn / Jednostka certyfikująca**
- VII **Konformitäts-Bewertungsverfahren / Conformity assessment procedure followed / la procédure appliquée pour l'évaluation de la conformité et / procedura di valutazione della conformità / procedimiento de evaluación de la conformidad / gevolgde overeenstemmingsbeoordelingsprocedure / den fulgte overensstemmelssesvurderingsprocedure / procedimento de avaliacao de conformidade / Vilket förfarande för bedömning av överensstämmelse / Przebieg kontroli**

**Vibrationsplatte
CR 5**



P = 7,3 kW

LWA = 107 dB (A)

LWA = 108 dB (A)

**RWTÜV
Postfach 103161
D-45032 Essen**

**interne Fertigungskontrolle
nach Anhang VI
EG Richtlinie 2000/14/EG**

ist in Übereinstimmung mit folgenden Richtlinien hergestellt worden / has been produced in accordance with following standards / est produit conforme aux dispositions des directives européennes ci-apres / ha sido fabricado en conformidad con las siguientes normas / é stato fabbricato in conformità alle sequenti norme / er blevet fremstillet i overensstemmelse med følgende retningslinier / in overeenstemming met de volgende voorschriften gefabriceerd is / é fabricado conforme as seguintes normas / har tillverkats i överensstämmelse med följande riktlinjer / Zgodność z obowiązującymi przepisami

98/37/EG Maschinenrichtlinie des europäischen Parlamentes und des Rates vom 22. Juni 1998
2000/14/EG EG-Richtlinie Geräuschemissionen vom 8. Mai 2000
EN 500 Teil 1 Bewegliche Straßenbaumaschinen – Sicherheit
Gemeinsame Anforderungen
EN 500 Teil 4 Bewegliche Straßenbaumaschinen – Sicherheit
Besondere Anforderungen an Verdichtungsmaschinen

Bescheinigung bitte sorgfältig aufbewahren / File certificate carefully / Conserver certificat soigneusement / Conserver certificado cuidadosamente / Pregasi conservare accuratamente certificato / Beviset bedes opbevares omhyggeligt / Verklaring a.u.b. zorgvuldig bevarer / Conserver o certificado com cuidado / Beviset skall om sorgsfullt bevaras // Deklarację zgodności proszę zachować

Bad Laasphe – Rückershausen, den **02.01.2004**

W. Weber, Geschäftsführer

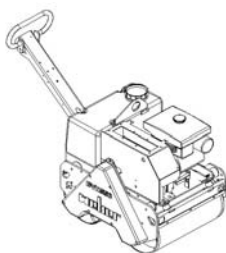

WEBER Maschinentechnik GmbH

Im Boden 5-8, 10 – D-57334 Bad Laasphe
Postfach 2153 – D-57329 Bad Laasphe
Telefon: 02754/398-0 – Fax 02754/398-101
E-mail: Verkauf@webermt.de
Internet: <http://www.webermt.de>



BITTE, NOTIEREN SIE SERIENNUMMER UND MOTORNUMMER IHRER MASCHINE:

PLEASE WRITE DOWN SERIALNUMBERS OF MACHINE AND ENGINE:

NOTEZ SVP LE NUMERO DE SERIE ET LE NUMERO DU MOTEUR DE VOTRE MACHINE:

SI PREGA DI ANNOTARE SEMPRE I NUMERI DI SERIE SIA DELLA VS. MACCHINA CHE DEL MOTORE:

MAQUINA: ROGAMOS ANOTEN EL NUMERO DE SERIE Y NUMERO DE MOTOR DE SU MAQUINA:

MASCHINE
MACHINE
MACCHINA
MAQUINA

#

MOTOR
ENGINE
MOTEUR
MOTORE

#

ZUR VERMEIDUNG VON FEHLLIEFERUNGEN UND VERZÖGERUNGEN SIND BEI DER BESTELLUNG VON ERSATZTEILEN FOLGENDE ANGABEN UNBEDINGT ERFORDERLICH:

- MASCHINENTYP
- SERIENNUMMER DER MASCHINE
- SERIENNUMMER DES MOTORS (BEI MOTORTEILEN)
- TEILENUMMER
- BESTELLMENGE

TO AVOID ERRORS IN DELIVERY PLEASE STATE THESE PARTICULARS WHEN ORDERING:

- TYPE OF MACHINE
- SERIAL NO. OF MACHINE
- SERIAL NO. OF ENGINE (ON ENGINE PARTS)
- PART-NO.
- QUANTITY REQUIRED

AFIN D'EVITER DES ERREURS DE COMMANDE ET DES RETARDS DE LIVRAISON IL EST NECESSAIRE D'INDIQUER LES CARACTERISTIQUES SUIVANTES:

- TYPE DE MACHINE
- LE NUMERO DE SERIE DE LA MACHINE
- LE NUMERO DE SERIE DU MOTEUR
- LE NUMERO D'IDENTITE DE LA PIECE
- LA QUANTITE SOUHAITEE

ONDE EVITARE DISGUIDI E RITARDI NELLE CONSEGNE DIE RICAMBI SI PREGA DI INDICARE SEMPRE:

- TIPO DELLA MACCHINA
- NUMERO DI SERIE DELLA MACCHINA
- NUMERO DI SERIE DEL MOTORE (SE SI RICHIEDONO PEZZI DEL MOTORE)
- NUMERO D'ORDINE DIE SINGOLI RICAMBI
- QUANTITA

A FI DE EVITAR ERRORES DE ENTREGA, ROGAMOS INDIQUEN LOS SIGUIENTES DATOS CUANDO PASE PEDIDOS DE RECAMBIO:

- MODELO DE MAQUINA
- NO. DE SERIE DE LA MAQUINA
- NO. DE SERIE DEL MOTOR (EN PIEZAS PARA MOTOR)
- REFERENCIA DEL RECAMBIO
- CANTIDAD PEDIDA

E 3015-0304

Position Ref.No. Repère Posizione Posicion	Menge Quantity Quantité Quantita Cantidad	Teile-Nr. Part-No. No. Référence Nr. d'Ordine No. Referenzia	Hinweis Hints Indications Indicazione Indicaciones	Position Ref. No. Repère Posizione Posicion	Menge Quantity Quantité Quantita Cantidad	Teile-Nr. Part-No. No. Référence Nr. d'Ordine No. Referenzia	Hinweis Hints Indications Indicazione Indicaciones
1	1	10016313					
2	1	25030002	DIN908-M14x1,5				
3	4	20004059					
4	4	20029030	SKM 16				
5	4	25031006	DIN934-M16				
6	1	10016417					
7	1	10016418					
8	1	10001436					
9	6	25045047	DIN912-M12x90				
10	2	25045048	DIN912-M12x150				
11	8	20029026					
12	4	25038023	DIN933-M16x25				
13	4	20029002	VSK 16				
14	4	10016445	Lombardini				

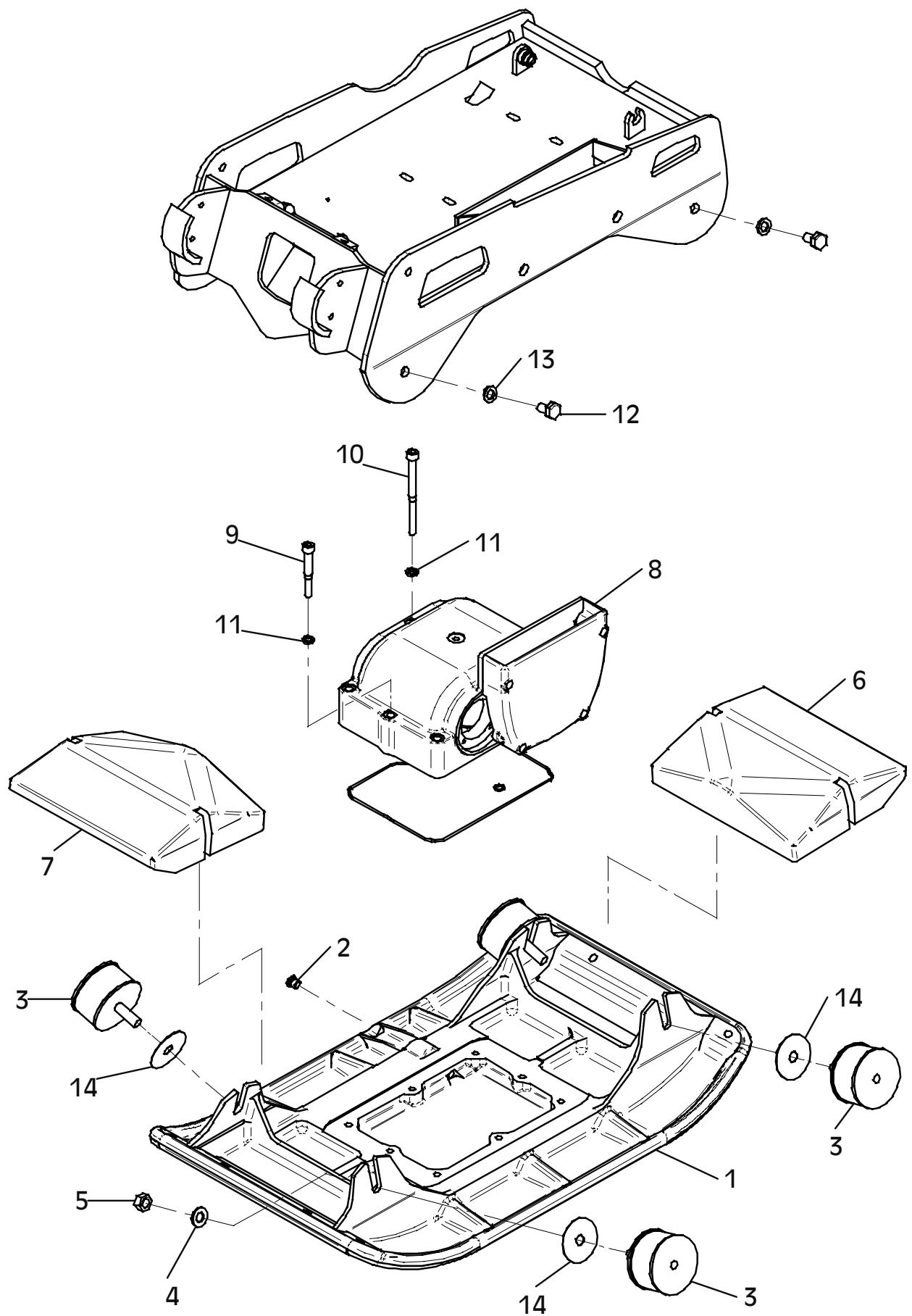

E 3015-0304

E 3016-0304

Position Ref.No. Repère Posizione Posicion	Menge Quantity Quantité Quantita Cantidad	Teile-Nr. Part-No. No. Référence Nr. d'Ordine No. Referenzia	Hinweis Hints Indications Indicazione Indicaciones	Position Ref. No. Repère Posizione Posicion	Menge Quantity Quantité Quantita Cantidad	Teile-Nr. Part-No. No. Référence Nr. d'Ordine No. Referenzia	Hinweis Hints Indications Indicazione Indicaciones
1	1	10016314					
2	1	25030002	DIN908-M14x1,5				
3	4	20004059					
4	4	20029030	SKM 16				
5	4	25031006	DIN934-M16				
6	1	10016417					
7	1	10016418					
8	1	10001436					
9	6	25045047	DIN912-M12x90				
10	2	25045048	DIN912-M12x150				
11	8	20029026					
12	4	25038023	DIN933-M16x25				
13	4	20029002	VSK 16				
14	4	10016445	Lombardini				

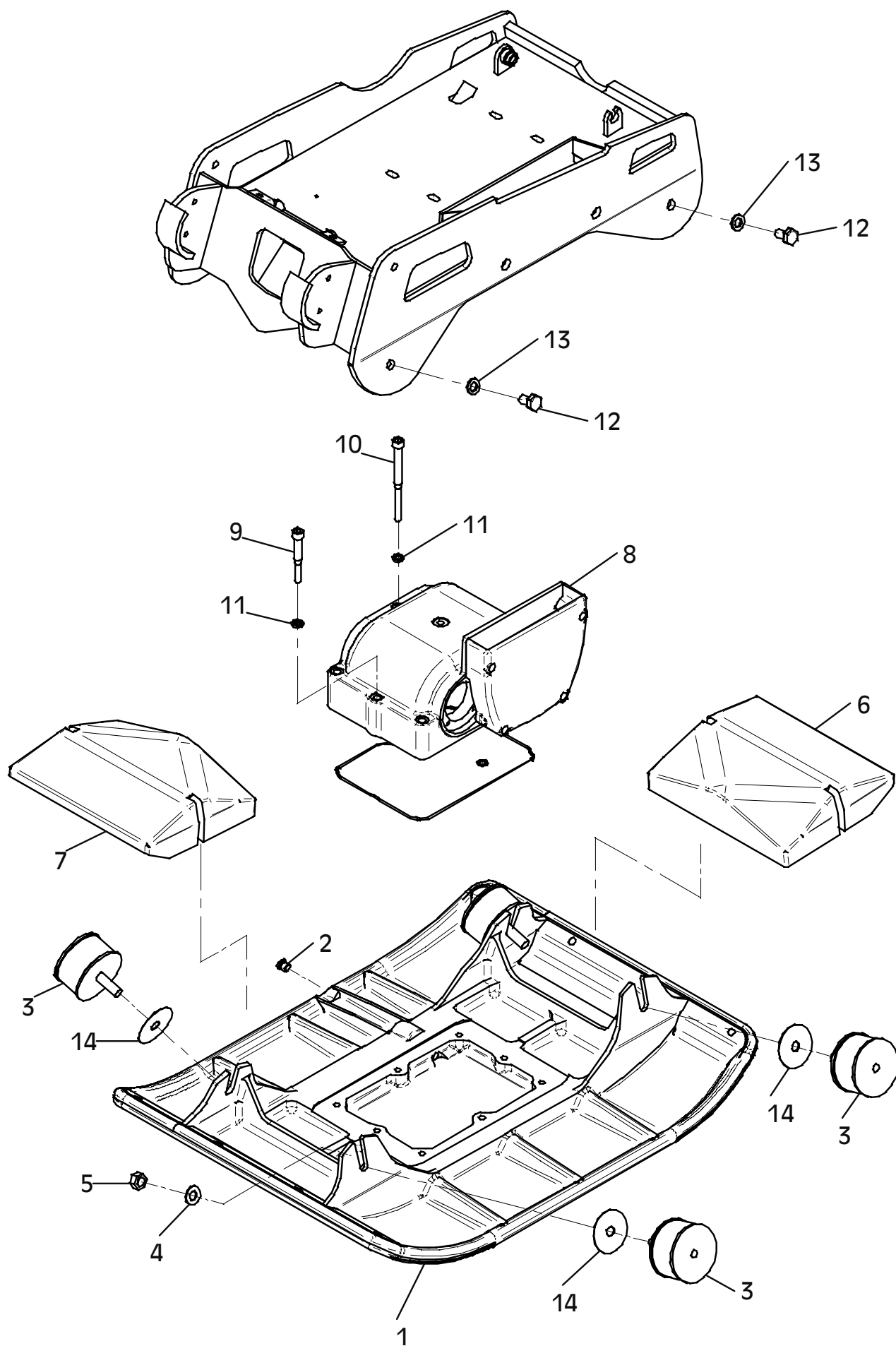

E 3016-0304

E 3017-0304

Position Ref.No. Repère Posizione Posicion	Menge Quantity Quantité Quantità Cantidad	Teile-Nr. Part-No. No. Référence Nr. d'Ordine No. Referenzia	Hinweis Hints Indications Indicazione Indicaciones	Position Ref. No. Repère Posizione Posicion	Menge Quantity Quantité Quantità Cantidad	Teile-Nr. Part-No. No. Référence Nr. d'Ordine No. Referenzia	Hinweis Hints Indications Indicazione Indicaciones
1	1	10016404		30	1	10016064	
2	1	25039005	DIN933-M12x20	31	1	20013269	
3	1	25008011	DIN7603-12x18x1,5	32	4	20029011	VSKZ 8
4	1	10016405		33	4	25044100	DIN912-M8x16
5	4	25044055	DIN912-M8x50	34	1	25008012	DIN7603-10x16x1
6	4	20029011	VSKZ 8	35	1	25030016	DIN910-M10x1
7	1	10016701		36	1	20020119	
8	1	10016071		37	2	25001157	
9	1	20029001	VSK 10	38	1	10016407	
10	1	10007370		39	2	25001135	
11	1	10016061		40	1	10016409	
12	4	20029011	VSKZ 8	41	1	25015046	
13	4	25044100	DIN912-M8x16	42	1	10016693	
14	1	20013269		43	2	25025157	
15	1	25017047		44	2	25045044	DIN912-M12x25
16	2	25001157		45	1	10016446	
17	1	10016407		46	1	10016414	
18	1	10016406		47	1	10016410	
19	1	25015046		48	1	25027004	DIN914-M8x16
20	1	10016692		49	1	10016413	
21	2	25025157		50	1	25035026	DIN472-I28x1,2
22	2	25045045	DIN912-M12x35	51	1	25001513	
23	0	20025528		52	1	25034002	DIN471-A12
24	0	20025029		53	1	10016066	
25	0	20025378		54	1	20013270	
26	2	20013269		55	1	20013302	
27	2	10016060		56	1	20013103	
28	8	20029011	VSKZ 8				
29	8	25044100	DIN912-M8x16				

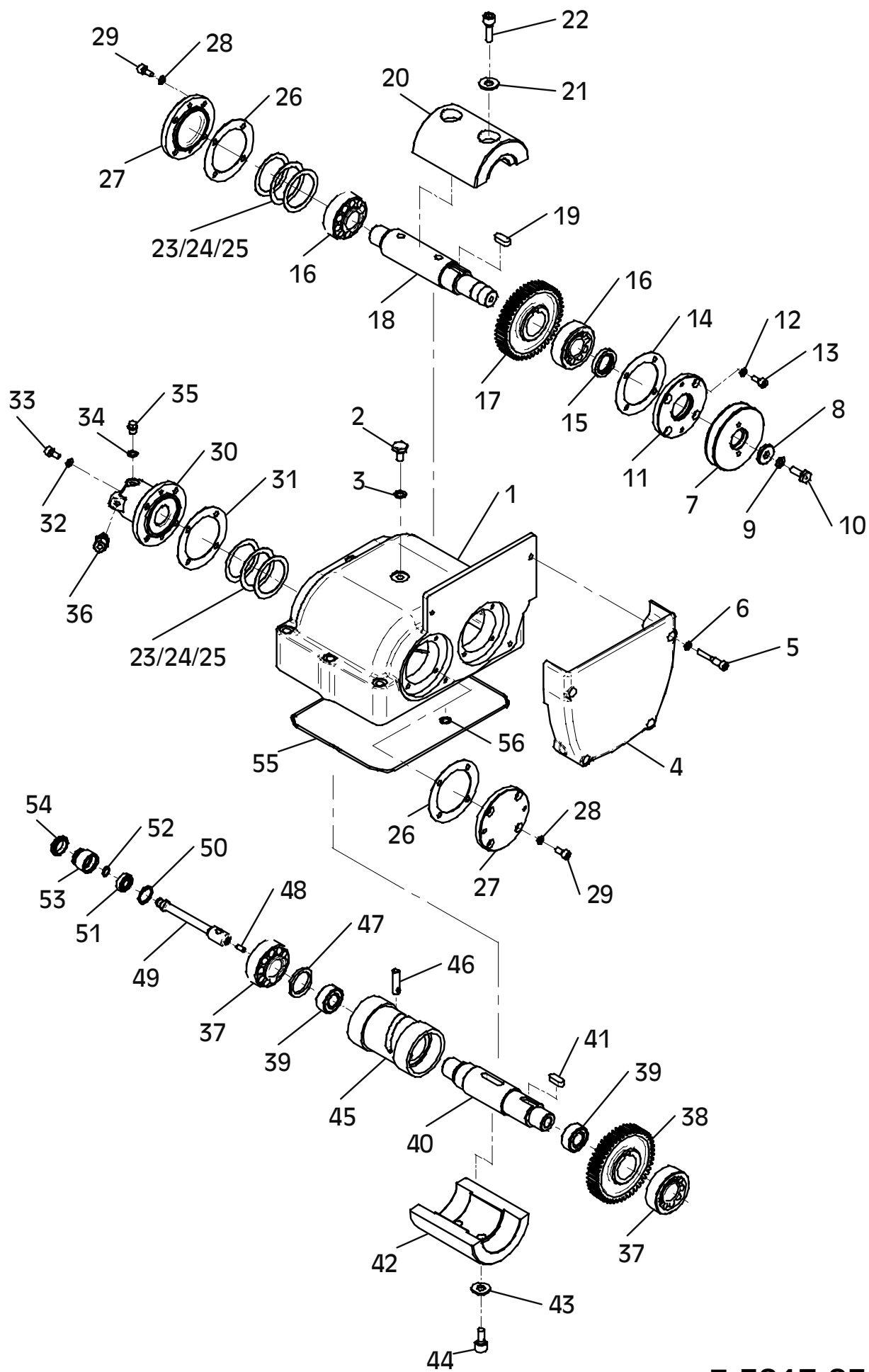

E 3017-0304

E 3018-0102

Position Ref.No. Repère Posizione Posicion	Menge Quantity Quantité Quantità Cantidad	Teile-Nr. Part-No. No. Référence Nr. d'Ordine No. Referenzia	Hinweis Hints Indications Indicazione Indicaciones	Position Ref. No. Repère Posizione Posicion	Menge Quantity Quantité Quantità Cantidad	Teile-Nr. Part-No. No. Référence Nr. d'Ordine No. Referenzia	Hinweis Hints Indications Indicazione Indicaciones
1	1	10022524		30	4	25044095	DIN912-M8x90
2	1	10016321		31	1	25008016	
3	3	25038006	DIN933-M8x16	32	1	20025702	
4	3	20029003	VSK 8	33	1	25031002	DIN934-M6
5	3	25048002	DIN125-A8,4	34	1	20007007	
6	1	20007007		35	1	20029007	VSK 6
7	1	20029007	VSK 6	36	1	25044003	DIN912-M6x20
8	1	25038002	DIN933-M6x16	37	1	10022525	
9	1	25009021		38	4	25038022	DIN933-M12x40
10	1	20025704		39	6	20029004	VSK 12
11	1	20025434		40	2	25031027	DIN1587-M12
12	1	20001235		41	1	20026465	
13	4	25033013	DIN603-M10x50	42	2	25025191	
14	4	25048010	DIN1440-11x25x3	43	2	20025019	
15	4	20022003	Tensilock M10				
16	1	10016395					
17	1	10022523					
18	6	20029003	VSK 8				
19	6	25040048	DIN931-M8x30				
20	1	20002088					
21	1	25002176					
22	1	20026475					
23	1	20029011	VSKZ 8				
24	1	25044046	DIN912-M8x55				
25	1	10016320					
26	4	20029003	VSK 8				
27	4	25038006	DIN933-M8x16				
28	1	10016273					
29	4	20029011	VSKZ 8				

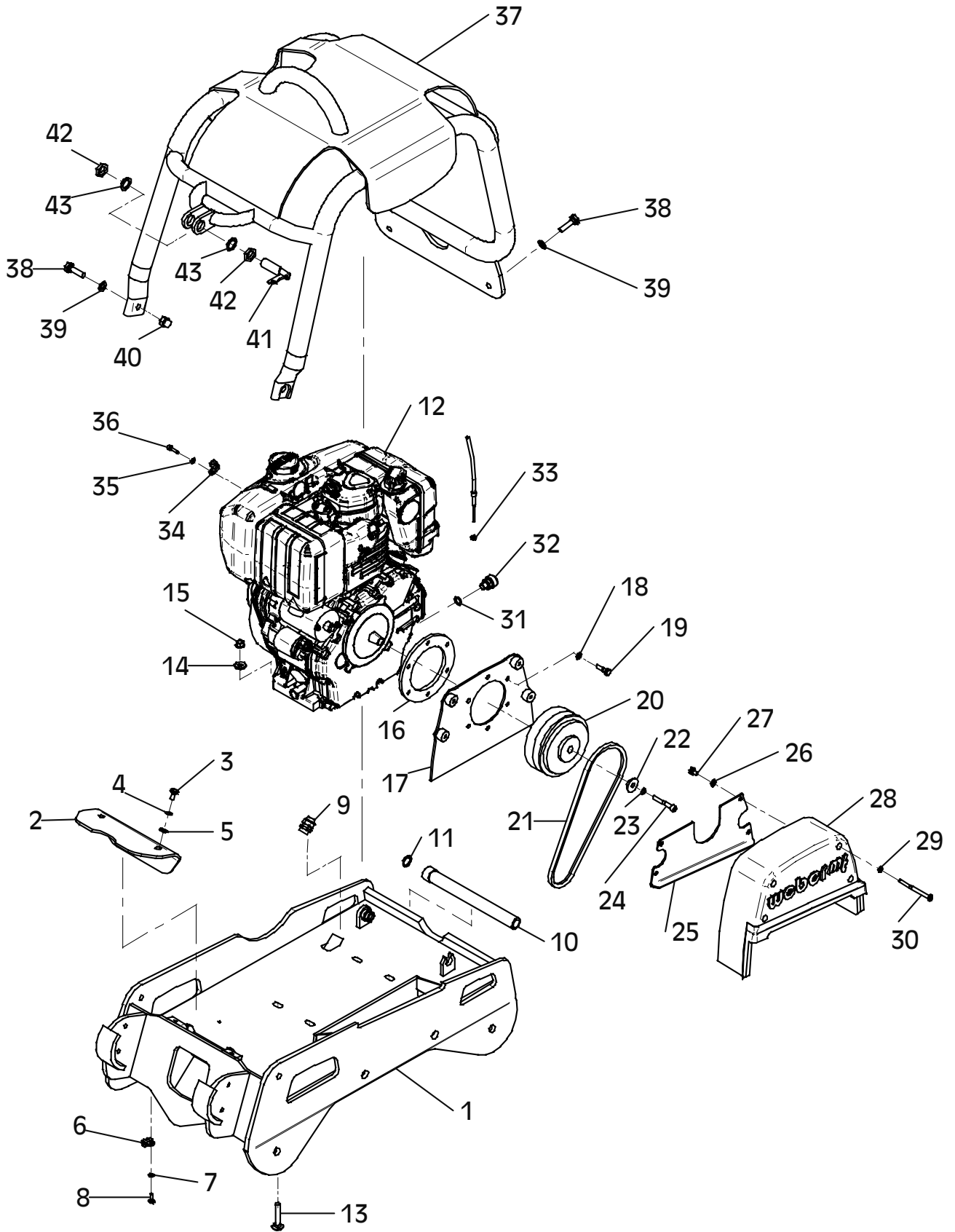

E 3034-0304

Position Ref.No. Repère Posizione Posicion	Menge Quantity Quantité Quantità Cantidad	Teile-Nr. Part-No. No. Référence Nr. d'Ordine No. Referenzia	Hinweis Hints Indications Indicazione Indicaciones	Position Ref. No. Repère Posizione Posicion	Menge Quantity Quantité Quantità Cantidad	Teile-Nr. Part-No. No. Référence Nr. d'Ordine No. Referenzia	Hinweis Hints Indications Indicazione Indicaciones
1	1	10022560		30	4	25044095	DIN912-M8x90
2	1	10022563		31	1	25008016	DIN 7603-14x18x1,5
3	2	25038006	DIN933-M8x16	32	1	20025702	
4	2	20029003	VSK 8	33	1	25031002	DIN934-M6
5	2	25048002	DIN125-A8,4	34	1	20007007	
6	1	20007007		37	1	10022525	
7	1	20029007	VSK 6	38	4	25038022	DIN933-M12x40
8	1	25038002	DIN933-M6x16	39	4	20029004	VSK 12
9	1	25009021		41	1	20026465	
10	1	20025704		42	2	25025191	DIN6796-16
11	1	20025434		43	2	20025019	
12	1	20001236		44	1	25033027	DIN603-M10x60
13	3	25033013	DIN603-M10x50	45	2	25048003	DIN125-A10,5
14	4	25048010	DIN1440-11x25x3	46	1	25031014	DIN985-M10
15	4	20022003	Tensilock M10	47	1	10016539	
16	1	10016395		48	2	25044002	DIN912-M6x16
17	1	10022523		49	2	20029015	VSKZ 6
18	6	20029003	VSK 8				
19	6	25040048	DIN931-M8x30				
20	1	20002088					
21	1	25002176					
22	1	20026475					
23	1	20029011	VSKZ 8				
24	1	25044046	DIN912-M8x55				
25	1	10016320					
26	4	20029003	VSK 8				
27	4	25038006	DIN933-M8x16				
28	1	10016273					
29	4	20029011	VSKZ 8				

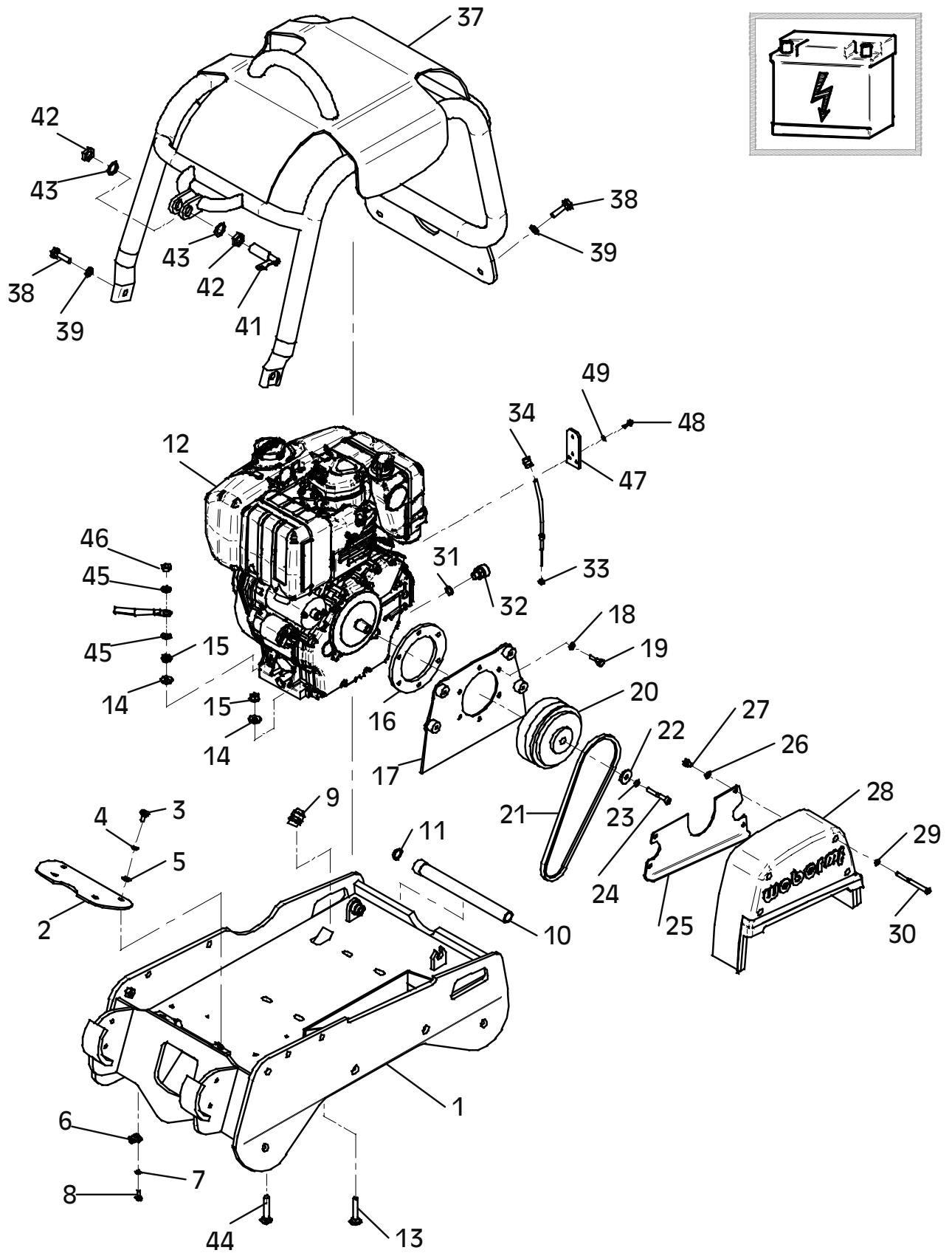
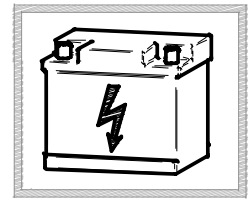

E 3033-0202

Position Ref.No. Repère Posizione Posicion	Menge Quantity Quantité Quantita Cantidad	Teile-Nr. Part-No. No. Référence Nr. d'Ordine No. Referenzia	Hinweis Hints Indications Indicazione Indicaciones	Position Ref. No. Repère Posizione Posicion	Menge Quantity Quantité Quantita Cantidad	Teile-Nr. Part-No. No. Référence Nr. d'Ordine No. Referenzia	Hinweis Hints Indications Indicazione Indicaciones
1	1	20002088					
2	2	20002548					
3	2	20002269					

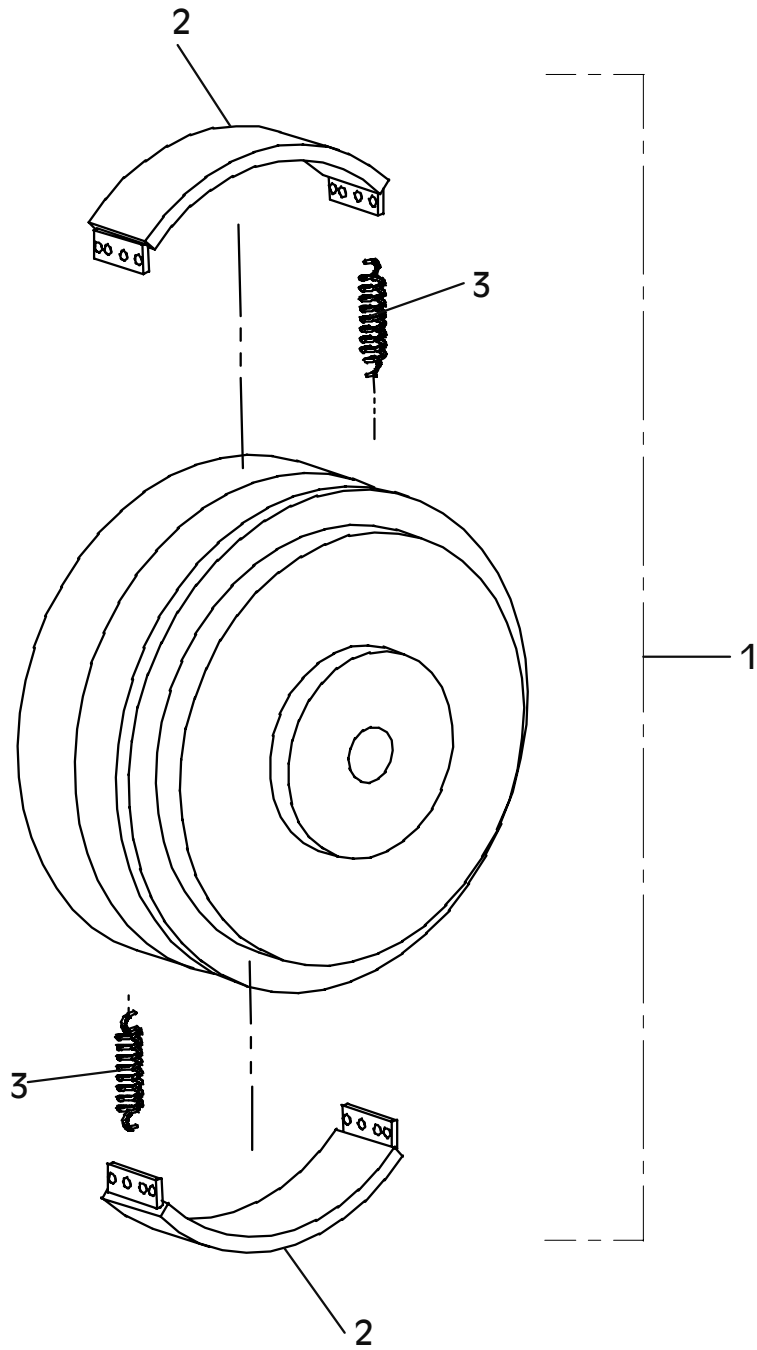

E 3033-0202

E 3035-0304

Position Ref.No. Repère Posizione Posicion	Menge Quantity Quantité Quantità Cantidad	Teile-Nr. Part-No. No. Référence Nr. d'Ordine No. Referenzia	Hinweis Hints Indications Indicazione Indicaciones	Position Ref. No. Repère Posizione Posicion	Menge Quantity Quantité Quantità Cantidad	Teile-Nr. Part-No. No. Référence Nr. d'Ordine No. Referenzia	Hinweis Hints Indications Indicazione Indicaciones
1	1	10003989		30	4	25049035	VSF 10
2	2	20029003	VSK 8	31	4	25038014	DIN933-M10x25
3	2	25038007	DIN933-M8x20	32	1	25044001	DIN912-M5x20
4	1	20031502					
5	2	10015530					
6	1	10015675					
7	1	20025566					
8	1	10015828					
9	1	10015631					
10	2	25020028					
11	10	25031003	DIN934-M8				
12	4	20029003	VSK 8				
13	1	10001433					
14	1	10001432					
15	1	20031541					
16	1	20031532					
17	1	25044076	DIN912-M5x16				
18	3	25048017	DIN125-A5,3				
19	2	20022005	Tensilock M5				
20	1	10016538					
21	1	40080599					
22	2	20029011	VSKZ 8				
23	2	25044063	DIN912-M8x35				
24	1	10001434					
25	2	20029020	SKB 6				
26	2	25038003	DIN933-M6x20				
27	1	10022562					
28	2	20029022	SKB 10				
29	2	25038013	DIN933-M10x20				

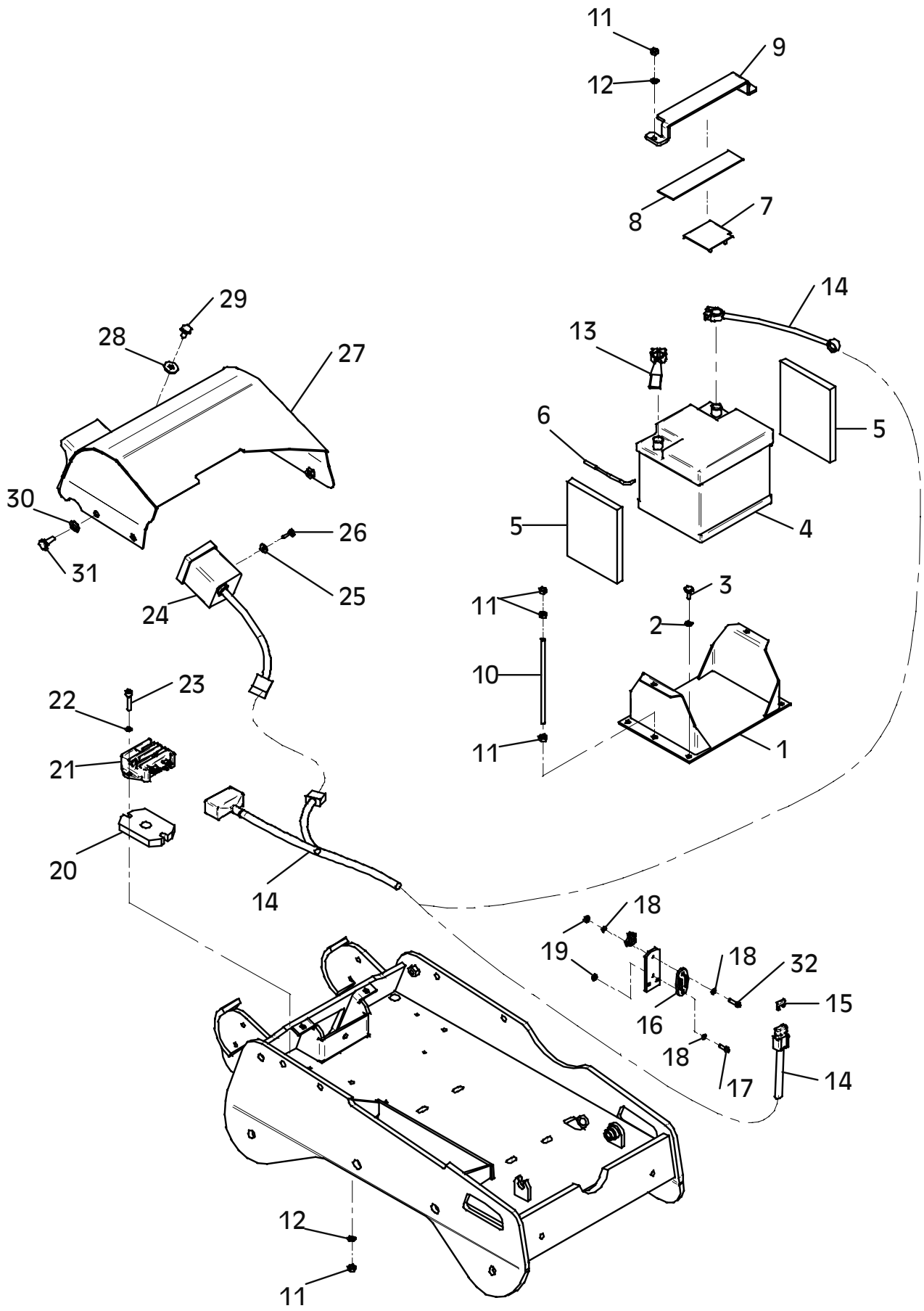

E 3019-0304

Position Ref.No. Repère Posizione Posicion	Menge Quantity Quantité Quantità Cantidad	Teile-Nr. Part-No. No. Référence Nr. d'Ordine No. Referenzia	Hinweis Hints Indications Indicazione Indicaciones	Position Ref. No. Repère Posizione Posicion	Menge Quantity Quantité Quantità Cantidad	Teile-Nr. Part-No. No. Référence Nr. d'Ordine No. Referenzia	Hinweis Hints Indications Indicazione Indicaciones
1	1	10022537		30	1	10022547	
2	1	10016321		31	4	25038006	DIN933-M8x16
3	3	25038006	DIN933-M8x16	32	4	20029003	VSK 8
4	3	20029003	VSK 8	33	1	10016273	
5	3	25048002	DIN125-A8,4	34	4	25044095	DIN912-M8x90
6	1	20007007		35	4	20029011	VSKZ 8
7	1	20029007	VSK 6	36	1	25008011	DIN7603-12x18x1,5
8	1	25038002	DIN933-M6x16	37	1	20026204	
9	1	10022550		38	1	20026383	
10	2	25044005	DIN912-M8x20	39	1	40001338	
11	2	20029011	VSKZ 8	40	1	20007007	
12	1	25009021		41	1	25048001	DIN125-B6,4
13	1	20025704		42	1	20029007	VSK 6
14	1	20025434		43	1	25038002	DIN933-M6x16
15	1	20001119		44	1	10022548	
16	2	10016449		45	4	25038022	DIN933-M12x40
17	4	25040045	DIN931-M10x70	46	6	20029004	VSK 12
18	4	20029022	SKB 10	47	2	25031027	DIN1587-M12
19	4	25048010	DIN1440-11x25x3	48	1	20026465	
20	4	20022003	Tensilock M10	49	2	25025191	DIN6796-16
21	1	10016448		50	2	20025019	
22	1	10022546		51	1	10016954	
23	4	25038007	DIN933-M8x20				
24	4	20029003	VSK 8				
25	1	20002087					
26	1	25002177					
27	1	20026475					
28	1	20029011	VSKZ 8				
29	1	25044007	DIN912-M8x30				

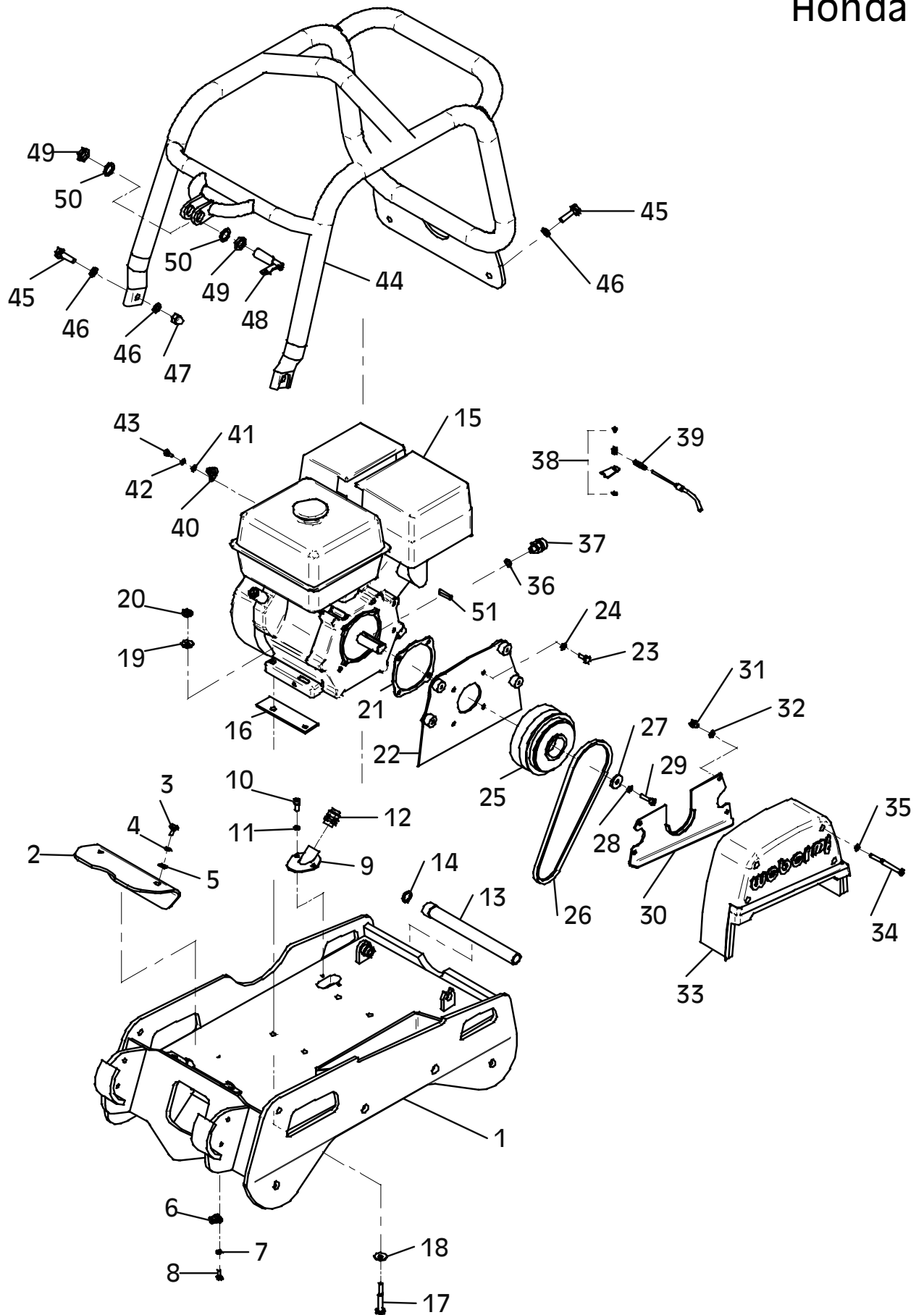

E 3028-0202

Position Ref.No. Repère Posizione Posicion	Menge Quantity Quantité Quantita Cantidad	Teile-Nr. Part-No. No. Référence Nr. d'Ordine No. Referenzia	Hinweis Hints Indications Indicazione Indicaciones	Position Ref. No. Repère Posizione Posicion	Menge Quantity Quantité Quantita Cantidad	Teile-Nr. Part-No. No. Référence Nr. d'Ordine No. Referenzia	Hinweis Hints Indications Indicazione Indicaciones
1	1	20002087					
2	2	20002548					
3	2	20002269					

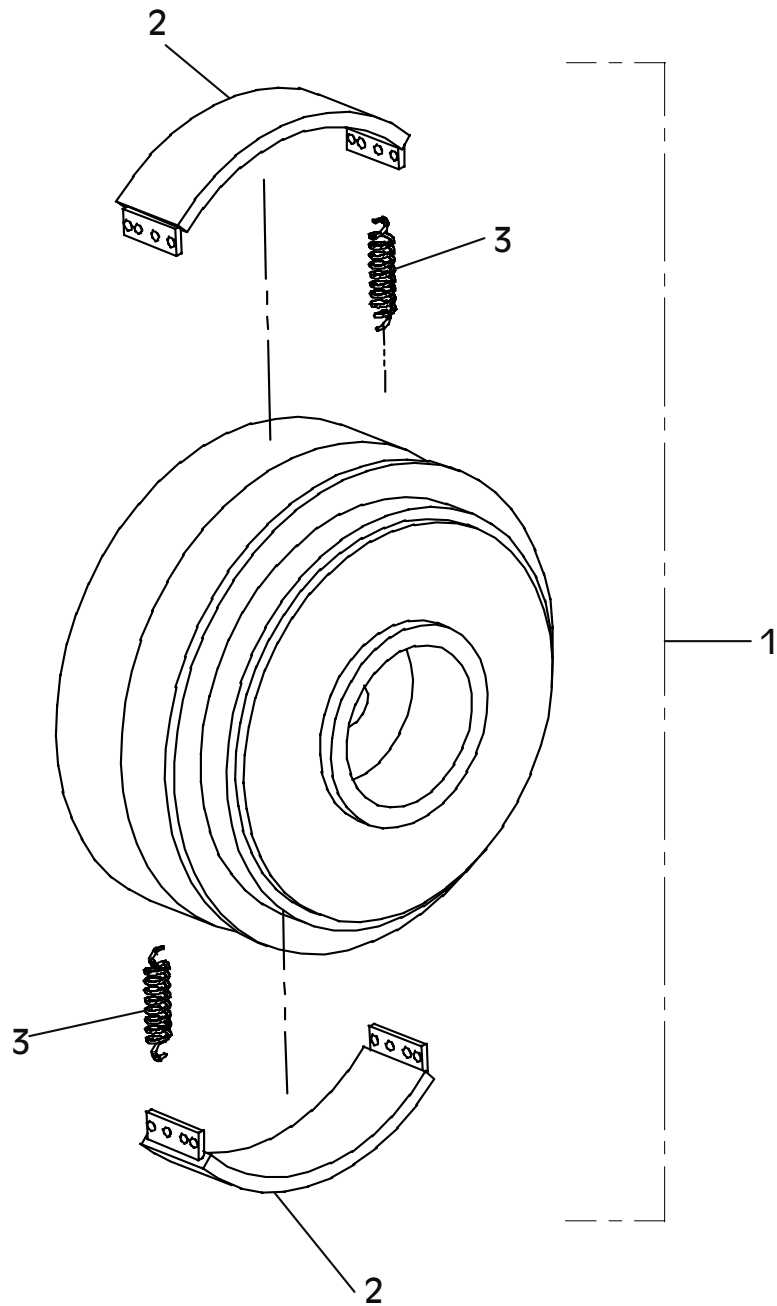

E 3028-0202

E 3020-0304

Position Ref.No. Repère Posizione Posicion	Menge Quantity Quantité Quantita Cantidad	Teile-Nr. Part-No. No. Référence Nr. d'Ordine No. Referenzia	Hinweis Hints Indications Indicazione Indicaciones	Position Ref. No. Repère Posizione Posicion	Menge Quantity Quantité Quantita Cantidad	Teile-Nr. Part-No. No. Référence Nr. d'Ordine No. Referenzia	Hinweis Hints Indications Indicazione Indicaciones
1	1	10022522		30	2	10022521	
2	2	10016331		31	2	20029023	SKB 12
3	8	20029011	VSKZ 8	32	2	25038020	DIN933-M12x30
4	8	25044046	DIN912-M8x55	33	2	20026468	
5	2	10016442		34	1	20008070	
6	2	20026493		35	1	10016022	
7	2	25040022	DIN931-M16x70	36	1	20013275	
8	2	20029002	VSK 16	37	1	10016102	
9	2	20026492		38	2	20013273	
10	2	20004016		39	1	20013274	
11	4	20029003	VSK 8	40	1	10016798	
12	4	25038008	DIN933-M8x25	41	1	20020119	
13	1	10016316		42	1	20016368	
14	1	10016319		43	1	25035027	DIN472-I58x2
15	1	25038079	DIN933-M20x35	44	4	20029011	VSKZ 8
16	1	20029009	VSK 20	45	4	25044007	DIN912-M8x30
17	1	25048006	DIN125-A21	46	1	10016358	Lombardini
18	1	20005005		46	1	10016100	Honda
19	1	20029001	VSK 10	47	1	20018134	
20	1	25031004	DIN934-M10	48	2	20029007	VSK 6
21	1	25009021		49	2	25040067	DIN931-M6x30
22	1	20007202		50	1	20018021	
23	1	10016797		51	1	20006415	
24	1	25008008	DIN7603-24x32x2	52	1	25030002	DIN908-M14x1,5
25	1	25030003	DIN908-M24x1,5				
26	1	10016776					
27	2	20013271					
28	2	10016101					
29	2	20013272					

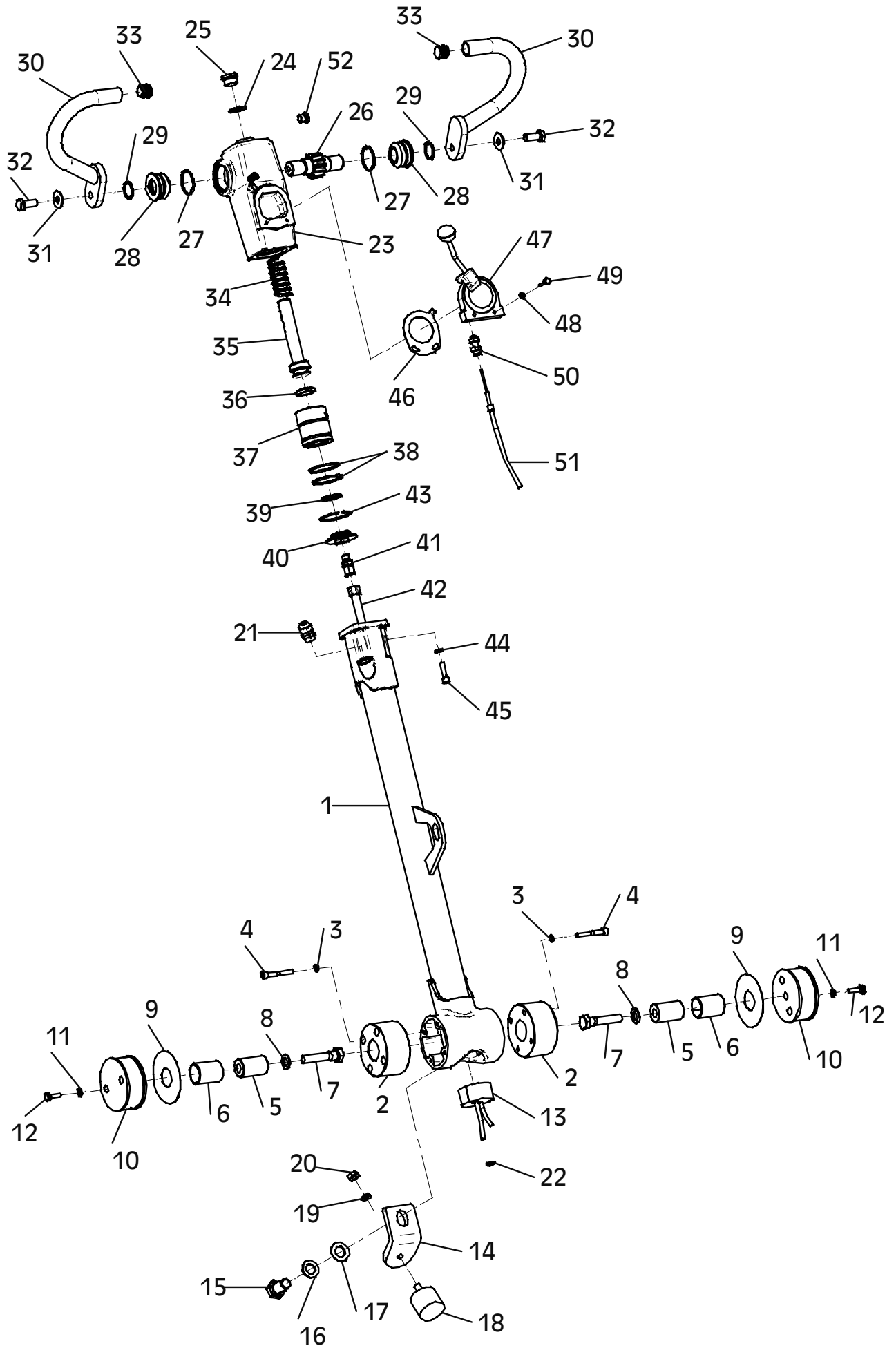

E 3020-0304

E 3021-0102

Position Ref.No. Repère Posizione Posicion	Menge Quantity Quantité Quantita Cantidad	Teile-Nr. Part-No. No. Référence Nr. d'Ordine No. Referenzia	Hinweis Hints Indications Indicazione Indicaciones	Position Ref. No. Repère Posizione Posicion	Menge Quantity Quantité Quantita Cantidad	Teile-Nr. Part-No. No. Référence Nr. d'Ordine No. Referenzia	Hinweis Hints Indications Indicazione Indicaciones
1	1	10016332					
2	2	10016334					
3	8	25040020	DIN931-M12x60				
4	8	20029004	VSK 12				
5	8	25031005	DIN934-M12				
6							
7							
8							
9							
10	1	10016333					
11	2	10016335					
12	8	25040020	DIN931-M12x60				
13	8	20029004	VSK 12				
14	8	25031005	DIN934-M12				

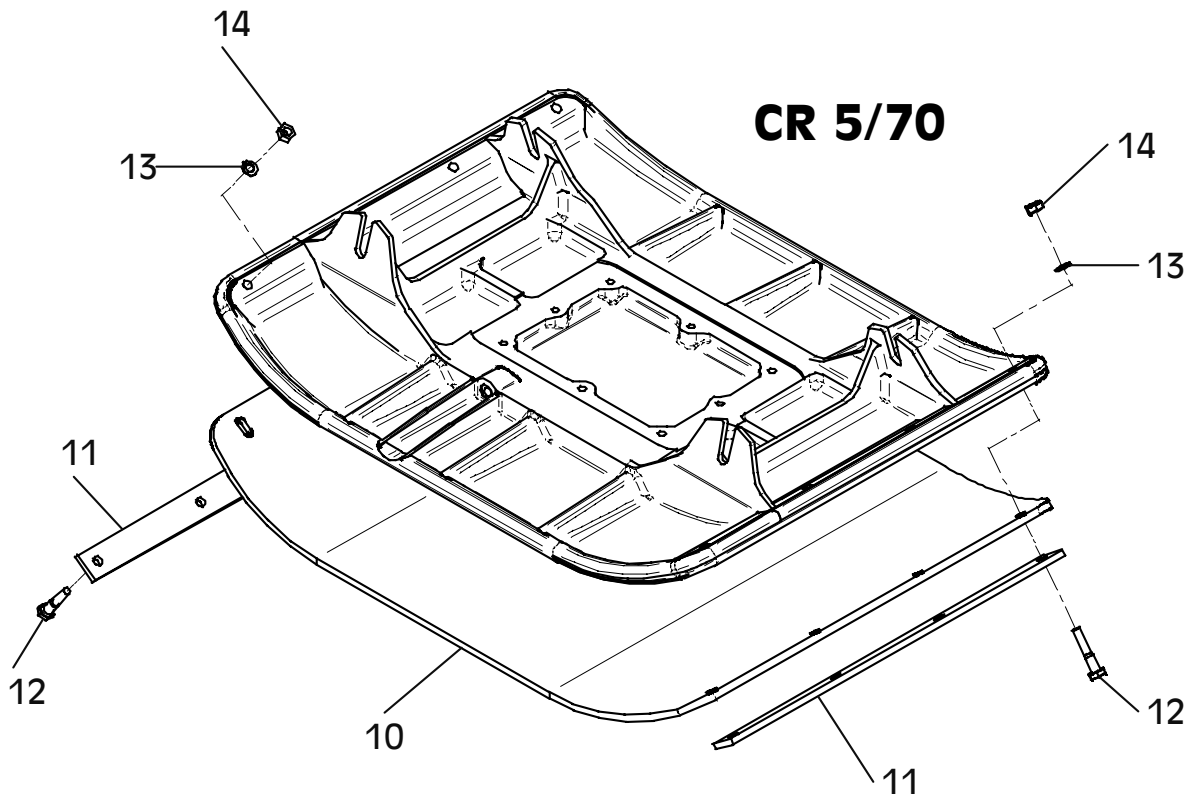
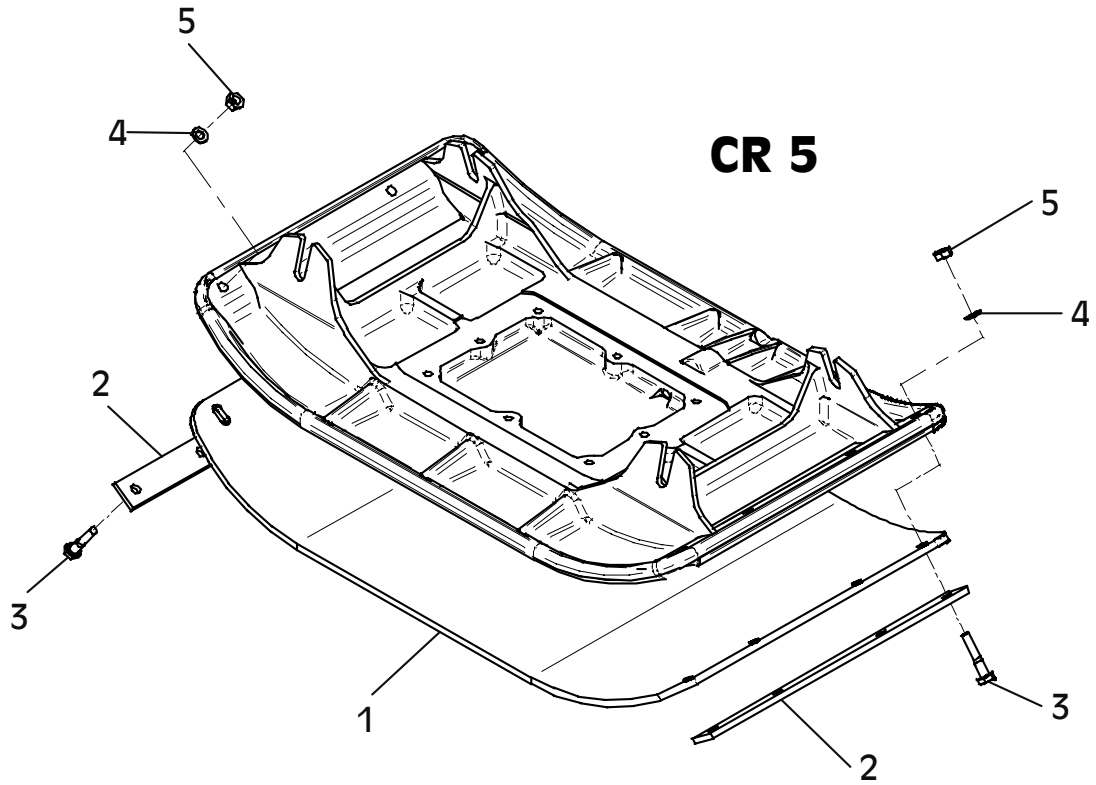

**Wenn Sie Fragen und Anregungen haben, oder sonstige Informationen benötigen,
wenden Sie sich bitte an eine der unten genannten Adressen:**

**For questions and further information refer to one of the
following addresses:**

<p>In Deutschland</p> <p>In Germany</p>	<p>WEBER Maschinenteknik GmbH Postfach 2153 57329 Bad Laasphe – Rückershausen</p> <p>Information / information: E-mail: info@webermt.de</p> <p>Ersatzteile / spare parts: E-mail: parts@webermt.de</p>	<p>Telefon / phone:</p> <p>Telefax / fax:</p> <p>Telefax / fax:</p>	<p>+49 (0) 2754 / 3980 Zentrale / switchboard</p> <p>+49 (0) 2754 / 398101 Zentrale / switchboard</p> <p>+49 (0) 2754 / 398102 Ersatzteile / spare parts direct dial</p>
<p>In Holland</p> <p>In Netherlands</p>	<p>WEBER Maschinenteknik B.V. Graafschap Hornelaan 159 6001 AC Weert</p> <p>E-mail: info@webermt.nl</p>	<p>Telefon / phone:</p> <p>Telefax / fax:</p>	<p>+31 (0) 495 / 530215</p> <p>+31 (0) 495 / 541839</p>
<p>In Frankreich</p> <p>In France</p>	<p>WEBER Technologie S.A.R.L. 26, rue d'Arsonval 69680 Chassieu</p> <p>E-mail: france@webermt.com</p>	<p>Telefon / phone:</p> <p>Telefax / fax:</p>	<p>+33 (0) 472 / 791020</p> <p>+33 (0) 472 / 791021</p>
<p>In Polen</p> <p>In Poland</p>	<p>WEBER Maschinenteknik SP.ZO.O. ul. Grodziska 7 05-830 Stara Wies / Nadarzyn</p> <p>E-mail: info@webermt.com.pl</p>	<p>Telefon / phone:</p> <p>Telefax / fax:</p>	<p>+48 (0) 22 / 7397080 +48 (0) 22 / 7397081</p> <p>+48 (0) 22 / 7397082</p>
<p>In USA, Kanada</p> <p>In USA, Canada</p>	<p>WEBER Machine (USA), Inc. 40 Johnson Ave 112 Bangor, ME 04401 USA</p> <p>E-mail: usa@webermt.com</p>	<p>Telefon / phone:</p> <p>Telefax / fax:</p>	<p>+1 (0) 207 / 9474990</p> <p>+1 (0) 207 / 9475452</p>
<p>In Südamerika</p> <p>In South America</p>	<p>WEBER Maschinenteknik do Brasil Ltda. Rua Sete de Setembro, 275 93332-470 Novo Hamburgo, RS Brasil</p> <p>E-mail: webermt@webermt.com.br</p>	<p>Telefon / phone:</p> <p>Telefax / fax:</p>	<p>+55 (0) 51 / 5873044</p> <p>+55 (0) 51 / 5872271</p>

<http://www.webermt.com>

