



ERSATZTEILLISTE

SPARE PARTS LIST

**LISTE DES PIECES
DE RECHANGE**

LISTINO RICAMBI

LISTA DE RECAMBIOS

**WYKAZ CZESCI
ZAMIENNYCH**



CR 5

0116251-0116259

Ab Masch.-Nr. 9004867

Weber Maschinentechnik GmbH
Postfach 2153, 57329 Bad Laasphe-Rückershausen
Telefon 02754 / 398-0
Telefax (02754) 398-101 (Zentrale) u. 398-102 (Ersatzteile)

EG - KONFORMITÄTSERKLÄRUNG

EC DECLARATION OF CONFORMITY/ DECLARATION DE CONFORMITE CE
DICHIARAZIONE CE DI CONFORMITA / DECLARACION CE DE CONFORMIDAD
EG-VERKLARING VAN OVEREENSTEMMING / EF-OVERENSSTEMMELSESERKAERING
DECLARACAO CE DE CONFORMIDADE / EG-FÖRSÄKRAN OM ÖVERENSSTÄMMELSE
DEKLARACJA ZGODNOŚCI

im Sinne der EG-Maschinenrichtlinie 98/37/EG
und der EG Richtlinie 2000/14/EG – Geräuschemissionen

- I **Hersteller/** Make / Marque / Marca / Marca / Producent / Merk / Marca /
Tillverkare / Producent **Weber Maschinentechnik GmbH**
Im Boden 5-8,10
57334 Bad Laasphe
- II **Art /** Category / Catégorie / Categoria Tipo / Kategori /
Soort / Categoria / kategori / Typ **Vibrationsplatte**
- III **Typ /** Type / Type / Tipo / Codice / Type / Type / Tipo / Typ / **CR 5 , CR 5 E**
- IV **Nennleistung /** Nominal-performance / La puissance nominale / Prestazione nominale /
Potencia nominal / Nominaal vermogen / Nominel ydelse / Potência nominal / Nominell
effect / Moc **P = 5,6 kW**
- V **gemessener Schalleistungspegel /** measured sound power level / niveau de
puissance acoustique mesure / livello di potenza sonora rilevato / nivel de potencia
acústica medido / gemeten geluidsvermogensniveau / målt lydeffektniveau / Nivel de
potência sonora midido / uppmätt ljudeffektnivå / Mierzony poziom dźwięku **LWA = 107 dB (A)**
- VI **garantierter Schalleistungspegel /** guaranteed sound power level / niveau de
puissance acoustique garanti / livello di potenza sonora garantito / nivel de potencia
acustica garantizado / gewaarborgd geluidsvermogensniveau / garanteret lydeffektniveau /
Nivel sonoro garantido / garanterad ljudeffektniva / Natężenie hałasu **LWA = 108 dB (A)**
- VII **beteiligte Zertifizierungsstelle /** notified body involved / de l'organisme notifié/
dell'organismo notificato che l'ha effettuata / dirección del organismo notificado que haya
intervenido / betrokken aangemelde instantie / pågældende bemyndigede organ /
organismo notificado involucrado / berörda anmälda organets namn / Jednostka
certyfikująca **RWTÜV**
Postfach 103161
D-45032 Essen
- VIII **Konformitäts-Bewertungsverfahren /** Conformity assessment procedure followed /
la procédure appliquée pour l'évaluation de la conformité et / procedura di valutazione
della conformità / procedimiento de evaluación de la conformidad / gevolgde
overeenstemmingsbeoordelingsprocedure / den fulgte
overensstemmelssesvurderingsprocedure / procedimento de avaliacao de conformidade
/ Vilket förfarande för bedömning av överensstämmelse / Przebieg kontroli **interne Fertigungskontrolle**
nach Anhang VI
EG Richtlinie 2000/14/EG

ist in Übereinstimmung mit folgenden Richtlinien hergestellt worden / has been produced in accordance with
following standards / est produit conforme aux dispositions des directives europeenes ci-apres / ha sido fabricado en conformidad
con las siguientes normas / é stato fabbricato in conformità alle sequenti norme / er blevet fremstillet i overensstemmelse med
følgende retningslinier / in overensstemming met de volgende voorschriften gefabriceerd is / é fabricado conforme as seguintes
normas / har tillverkats i överensstämmelse med följande riktlinjer / Zgodność z obowiązującymi przepisami

98/37/EG Maschinenrichtlinie des europäischen Parlamentes und des Rates vom 22. Juni 1998
2000/14/EG EG-Richtlinie Geräuschemissionen vom 8. Mai 2000
2005/88/EG EG-Richtlinie vom 14. Dez. 2005 zur Änderung der Richtlinie 2000/14/EG
EN 500 Teil 1 Bewegliche Straßenbaumaschinen – Sicherheit
Gemeinsame Anforderungen
EN 500 Teil 4 Bewegliche Straßenbaumaschinen – Sicherheit
Besondere Anforderungen an Verdichtungsmaschinen

Bescheinigung bitte sorgfältig aufbewahren / File certificate carefully / Conserver certificat soigneusement / Conservar
certificado cuidadosamente / Pregasi conservare accuratamente certificato / Beviset bedes opbevares omhyggeligt / Verklaring
a.u.b. zorgvuldig bevare / Conservar o certificado com cuidado / Beviset skall om sorgsfullt bevaras // Deklarację zgodności
proszę zachować

Bad Laasphe – Rückershausen, den **02.01.2009**

W. Weber, Geschäftsführer

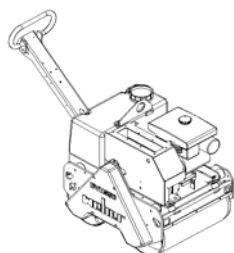

webermt

WEBER Maschinentechnik GmbH
Im Boden 5-8, 10 – D-57334 Bad Laasphe
Postfach 2153 – D-57329 Bad Laasphe
Telefon: 02754/398-0 – Fax 02754/398-101
E-mail: Verkauf@webermt.de
Internet: <http://www.webermt.de>



EG - KONFORMITÄTSERKLÄRUNG

EC DECLARATION OF CONFORMITY/ DECLARATION DE CONFORMITE CE
DICHIARAZIONE CE DI CONFORMITA / DECLARACION CE DE CONFORMIDAD
EG-VERKLARING VAN OVEREENSTEMMING / EF-OVERENSSTEMMELSESERKAERING
DECLARACAO CE DE CONFORMIDADE / EG-FÖRSÄKRAN OM ÖVERENSSTÄMMELSE
DEKLARACJA ZGODNOŚCI

im Sinne der EG-Maschinenrichtlinie 98/37/EG
und der EG Richtlinie 2000/14/EG – Geräuschemissionen

- | | | |
|------|---|--|
| I | Hersteller/ Make / Marque / Marca / Marca / Producent / Merk / Marca /
Tillverkare / Producent | Weber Maschinentechnik GmbH
Im Boden 5-8,10
57334 Bad Laasphe |
| II | Art / Category / Catégorie / Categoria Tipo / Kategori /
Soort / Categoria / kategori / Typ | Vibrationsplatte |
| III | Typ / Type / Type / Tipo / Codice / Type / Type / Tipo / Typ / | CR 5 Hd |
| IV | Nennleistung / Nominal-performance / La puissance nominale / Prestazione nominale /
Potencia nominal / Nominaal vermogen / Nominel ydelse / Potência nominal / Nominell
effect / Moc | P = 6,0 kW |
| V | gemessener Schalleistungspegel / measured sound power level / niveau de
puissance acoustique mesure / livello di potenza sonora rilevato / nivel de potencia
acústica medido / gemeten geluidsvermogensniveau / målt lydeffektniveau / Nivel de
potência sonora midido / uppmätt ljudeffektnivå / Mierzony poziom dźwięku | LWA = 107 dB (A) |
| VI | garantierter Schalleistungspegel / guaranteed sound power level / niveau de
puissance acoustique garanti / livello di potenza sonora garantito / nivel de potencia
acustica garantizado / gewaarborgd geluidsvermogensniveau / garanteret lydeffektniveau /
Nivel sonoro garantido / garanterad ljudeffektniva / Natężenie hałasu | LWA = 108 dB (A) |
| VII | beteiligte Zertifizierungsstelle / notified body involved / de l'organisme notifié/
dell'organismo notificato che l'ha effettuata / dirección del organismo notificado que haya
intervenido / betrokken aangemelde instantie / pågældende bemyndigede organ /
organismo notificado involucrado / berörda anmälda organets namn / Jednostka
certyfikująca | RWTÜV
Postfach 103161
D-45032 Essen |
| VIII | Konformitäts-Bewertungsverfahren / Conformity assessment procedure followed /
la procédure appliquée pour l'évaluation de la conformité et / procedura di valutazione
della conformità / procedimiento de evaluación de la conformidad / gevolgde
overeenstemmingsbeoordelingsprocedure / den fulgte
overensstemmelssesvurderingsprocedure / procedimento de avaliacao de conformidade
/Vilket förfarande för bedömning av överensstämmelse / Przebieg kontroli | interne Fertigungskontrolle
nach Anhang VI
EG Richtlinie 2000/14/EG |

ist in Übereinstimmung mit folgenden Richtlinien hergestellt worden / has been produced in accordance with following standards / est produit conforme aux dispositions des directives europeenes ci-apres / ha sido fabricado en conformidad con las siguientes normas / é stato fabbricato in conformità alle sequenti norme / er blevet fremstillet i overensstemmelse med følgende retningslinier / in overensstemming met de volgende voorschriften gefabriceerd is / é fabricado conforme as seguintes normas / har tillverkats i överensstämmelse med följande riktlinjer / Zgodność z obowiązującymi przepisami

98/37/EG	Maschinenrichtlinie des europäischen Parlamentes und des Rates vom 22. Juni 1998
2000/14/EG	EG-Richtlinie Geräuschemissionen vom 8. Mai 2000
2005/88/EG	EG-Richtlinie vom 14. Dez. 2005 zur Änderung der Richtlinie 2000/14/EG
EN 500 Teil 1	Bewegliche Straßenbaumaschinen – Sicherheit
EN 500 Teil 4	Gemeinsame Anforderungen Bewegliche Straßenbaumaschinen – Sicherheit Besondere Anforderungen an Verdichtungsmaschinen

Bescheinigung bitte sorgfältig aufbewahren / File certificate carefully / Conserver certificat soigneusement / Conservar certificado cuidadosamente / Pregasi conservare accuratamente certificato / Beviset bedes opbevares omhyggeligt / Verklaring a.u.b. zorgvuldig bevare / Conservar o certificado com cuidado / Beviset skall om sorgsfullt bevaras // Deklarację zgodności proszę zachować

Bad Laasphe – Rückershausen, den **02.01.2009**

W. Weber, Geschäftsführer

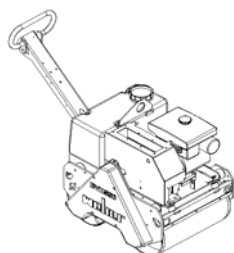

weberm

WEBER Maschinentechnik GmbH
Im Boden 5-8, 10 – D-57334 Bad Laasphe
Postfach 2153 – D-57329 Bad Laasphe
Telefon: 02754/398-0 – Fax 02754/398-101
E-mail: Verkauf@webermt.de
Internet: <http://www.webermt.de>



BITTE, NOTIEREN SIE SERIENNUMMER UND MOTORNUMMER IHRER MASCHINE:

PLEASE WRITE DOWN SERIALNUMBERS OF MACHINE AND ENGINE:

NOTEZ SVP LE NUMERO DE SERIE ET LE NUMERO DU MOTEUR DE VOTRE MACHINE:

SI PREGA DI ANNOTARE SEMPRE I NUMERI DI SERIE SIA DELLA VS. MACCHINA CHE DEL MOTORE:

MAQUINA: ROGAMOS ANOTEN EL NUMERO DE SERIE Y NUMERO DE MOTOR DE SU MAQUINA:

MASCHINE
MACHINE
MACCHINA
MAQUINA

#

MOTOR
ENGINE
MOTEUR
MOTORE

#

ZUR VERMEIDUNG VON FEHLLIEFERUNGEN UND VERZÖGERUNGEN SIND BEI DER BESTELLUNG VON ERSATZTEILEN FOLGENDE ANGABEN UNBEDINGT ERFORDERLICH:

- MASCHINENTYP
- SERIENNUMMER DER MASCHINE
- SERIENNUMMER DES MOTORS (BEI MOTORTEILEN)
- TEILENUMMER
- BESTELLMENGE

TO AVOID ERRORS IN DELIVERY PLEASE STATE THESE PARTICULARS WHEN ORDERING:

- TYPE OF MACHINE
- SERIAL NO. OF MACHINE
- SERIAL NO. OF ENGINE (ON ENGINE PARTS)
- PART-NO.
- QUANTITY REQUIRED

AFIN D'EVITER DES ERREURS DE COMMANDE ET DES RETARDS DE LIVRAISON IL EST NECESSAIRE D'INDIQUER LES CARACTERISTIQUES SUIVANTES:

- TYPE DE MACHINE
- LE NUMERO DE SERIE DE LA MACHINE
- LE NUMERO DE SERIE DU MOTEUR
- LE NUMERO D'IDENTITE DE LA PIECE
- LA QUANTITE SOUHAITEE

ONDE EVITARE DISGUIDI E RITARDI NELLE CONSEGNE DIE RICAMBI SI PREGA DI INDICARE SEMPRE:

- TIPO DELLA MACCHINA
- NUMERO DI SERIE DELLA MACCHINA
- NUMERO DI SERIE DEL MOTORE (SE SI RICHIEDONO PEZZI DEL MOTORE)
- NUMERO D'ORDINE DIE SINGOLI RICAMBI
- QUANTITA

A FI DE EVITAR ERRORES DE ENTREGA, ROGAMOS INDIQUEN LOS SIGUIENTES DATOS CUANDO PASE PEDIDOS DE RECAMBIO:

- MODELO DE MAQUINA
- NO. DE SERIE DE LA MAQUINA
- NO. DE SERIE DEL MOTOR (EN PIEZAS PARA MOTOR)
- REFERENCIA DEL RECAMBIO
- CANTIDAD PEDIDA

E 3367-0609

Position Ref.No. Repère Posizione Posicion	Menge Quantity Quantité Quantita Cantidad	Teile-Nr. Part-No. No. Référence Nr. d'Ordine No. Referenzia	Hinweis Hints Indications Indicazione Indicaciones	Position Ref. No. Repère Posizione Posicion	Menge Quantity Quantité Quantita Cantidad	Teile-Nr. Part-No. No. Référence Nr. d'Ordine No. Referenzia	Hinweis Hints Indications Indicazione Indicaciones
1	1	11000663					
2	1	25030002	DIN908-M14x1,5				
3	2	11000676					
4	6	21000554	DIN931-M16x55-10.9				
5	6	20029029					
6	1	11000674					
7	1	21000503					
8	10	25040027	DIN931-M8x35				
9	10	20029024					
10	2	11000664					
11	14	25038014	DIN933-M10x25				
12	14	20029025					
13	4	20004059					
14	4	25038023	DIN933-M16x25				
15	4	20029030	SKM 16				
16	4	20029030	SKM 16				
17	4	25031006	DIN934-M16				
18	1	11000809					
19	2	25044100	DIN912-M8x16				
20	2	20029003	VSK 8				
21	1	20007006					
22	1	25044005	DIN912-M8x20				
23	1	20029031	SKM 8				

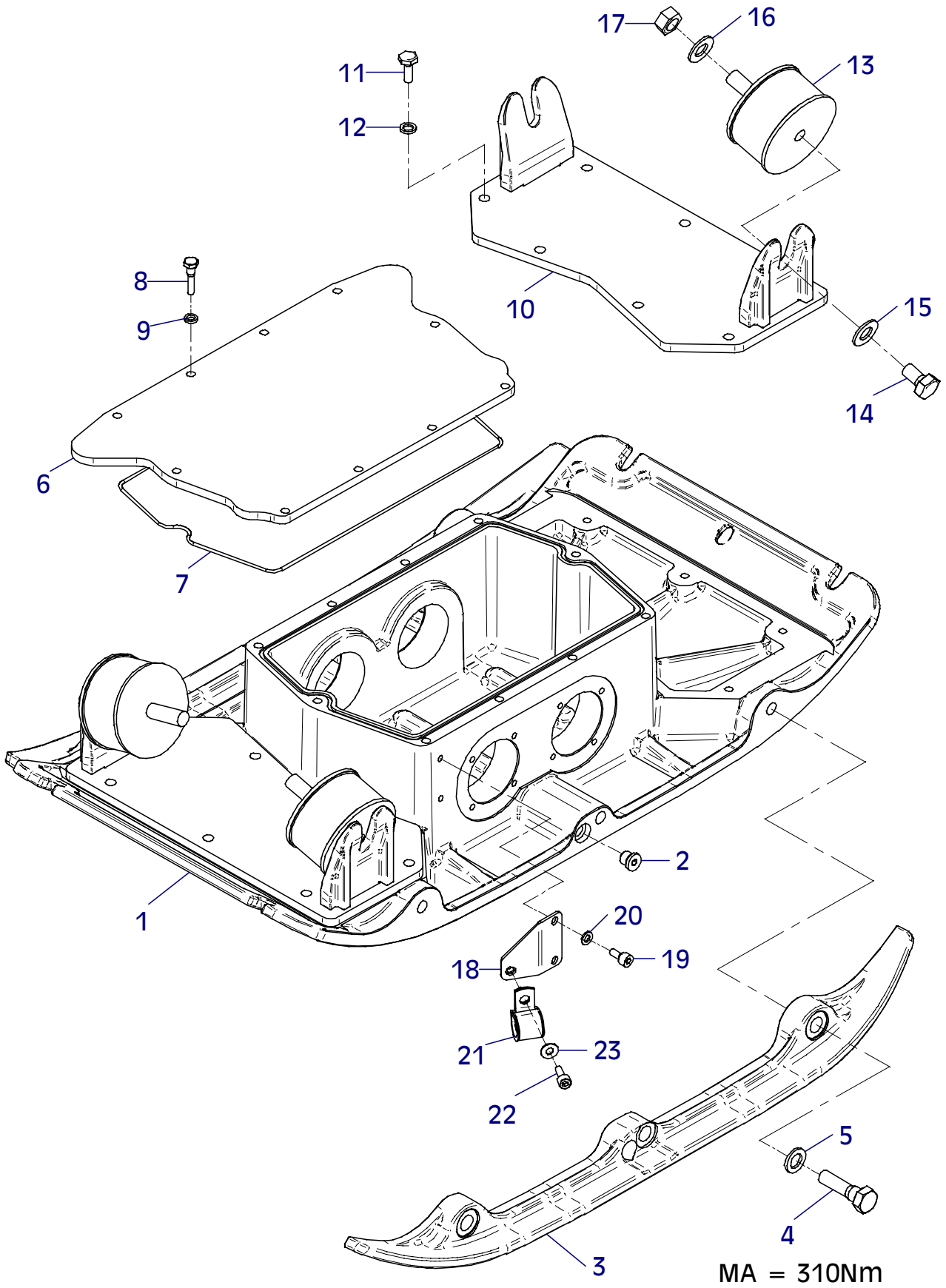

E 3367-0609

E 3368-0609

Position Ref.No. Repère Posizione Posicion	Menge Quantity Quantité Quantita Cantidad	Teile-Nr. Part-No. No. Référence Nr. d'Ordine No. Referenzia	Hinweis Hints Indications Indicazione Indicaciones	Position Ref. No. Repère Posizione Posicion	Menge Quantity Quantité Quantita Cantidad	Teile-Nr. Part-No. No. Référence Nr. d'Ordine No. Referenzia	Hinweis Hints Indications Indicazione Indicaciones
1	1	10016060					
2	1	20013269					
3	4	25044100	DIN912-M8x16				
4	4	20029011	VSKZ 8				
5	1	10016061					
6	1	11000851					
7	4	25044100	DIN912-M8x16				
8	4	20029011	VSKZ 8				
9	1	11000348					
10	1	20013269					
11	4	25044100	DIN912-M8x16				
12	4	20029011	VSKZ 8				
13	1	25030016	DIN910-M10x1				
14	1	25008012	DIN7603-10x16x1				
15	1	20020119					
16	1	11000672					
17	4	25044005	DIN912-M8x20				
18	4	20029024					
19	1	11000673					
20	5	25038006	DIN933-M8x16				
21	5	20029003	VSK 8				
22	1	10016060					
23	4	25046015	DIN7984-M8x16				
24	4	20029011	VSKZ 8				

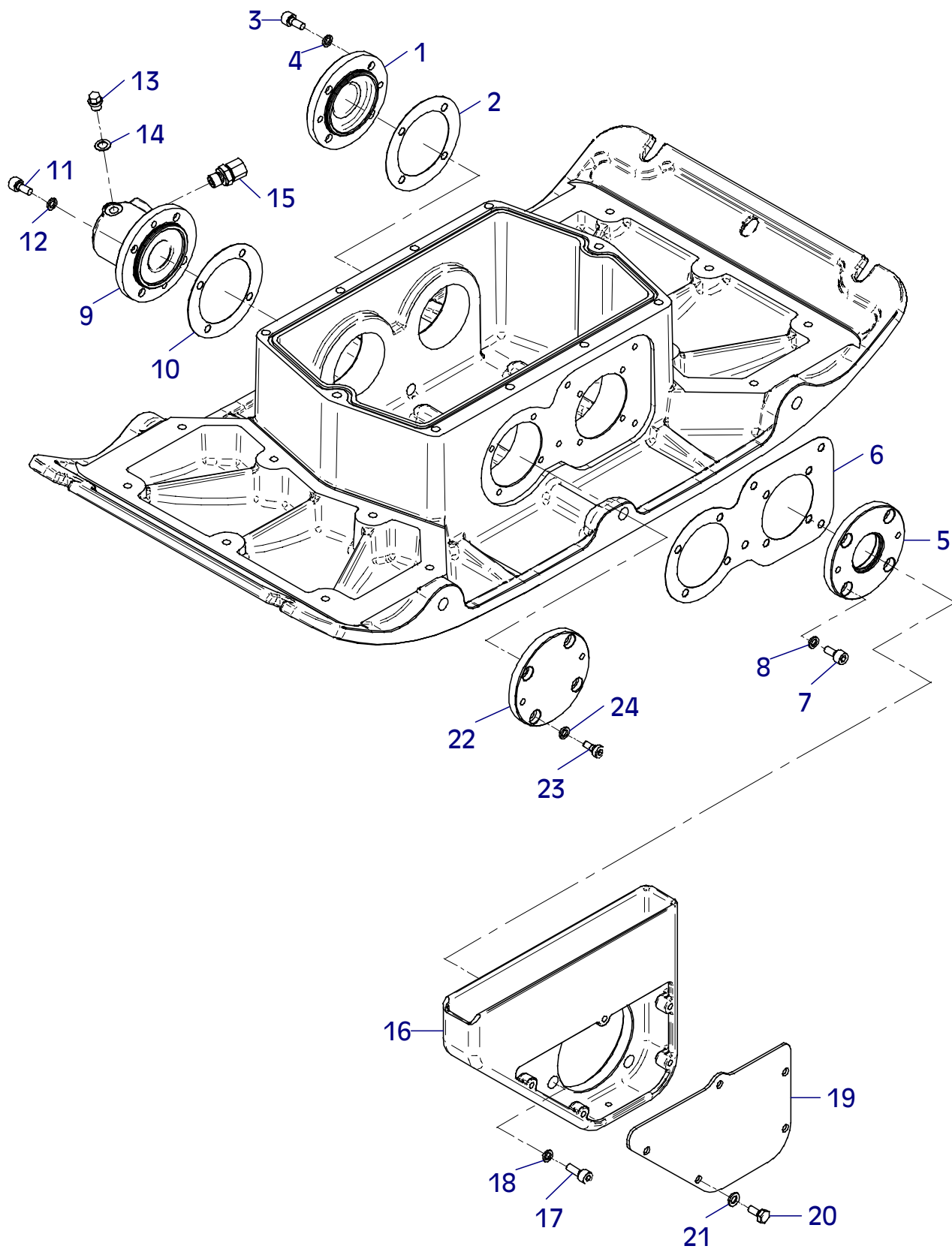

E 3368-0609

E 3369-0609

Position Ref.No. Repère Posizione Posicion	Menge Quantity Quantité Quantita Cantidad	Teile-Nr. Part-No. No. Référence Nr. d'Ordine No. Referenzia	Hinweis Hints Indications Indicazione Indicaciones	Position Ref. No. Repère Posizione Posicion	Menge Quantity Quantité Quantita Cantidad	Teile-Nr. Part-No. No. Référence Nr. d'Ordine No. Referenzia	Hinweis Hints Indications Indicazione Indicaciones
1	1	11000665					
2	1	11000666					
3	2	21000358	DIN912-M10x40-10.9				
4	2	25025245					
5	1	11000347					
6	1	25015016					
7	1	25034020	DIN471-A38x1,75				
8	2	25001144					
9	1	25017047					
10	1	11000667					
11	1	11000668					
12	4	25044005	DIN912-M8x20				
13	4	20029011	VSKZ 8				
14	1	10007370					
15	1	20029001	VSK 10				
16	1	10016071					

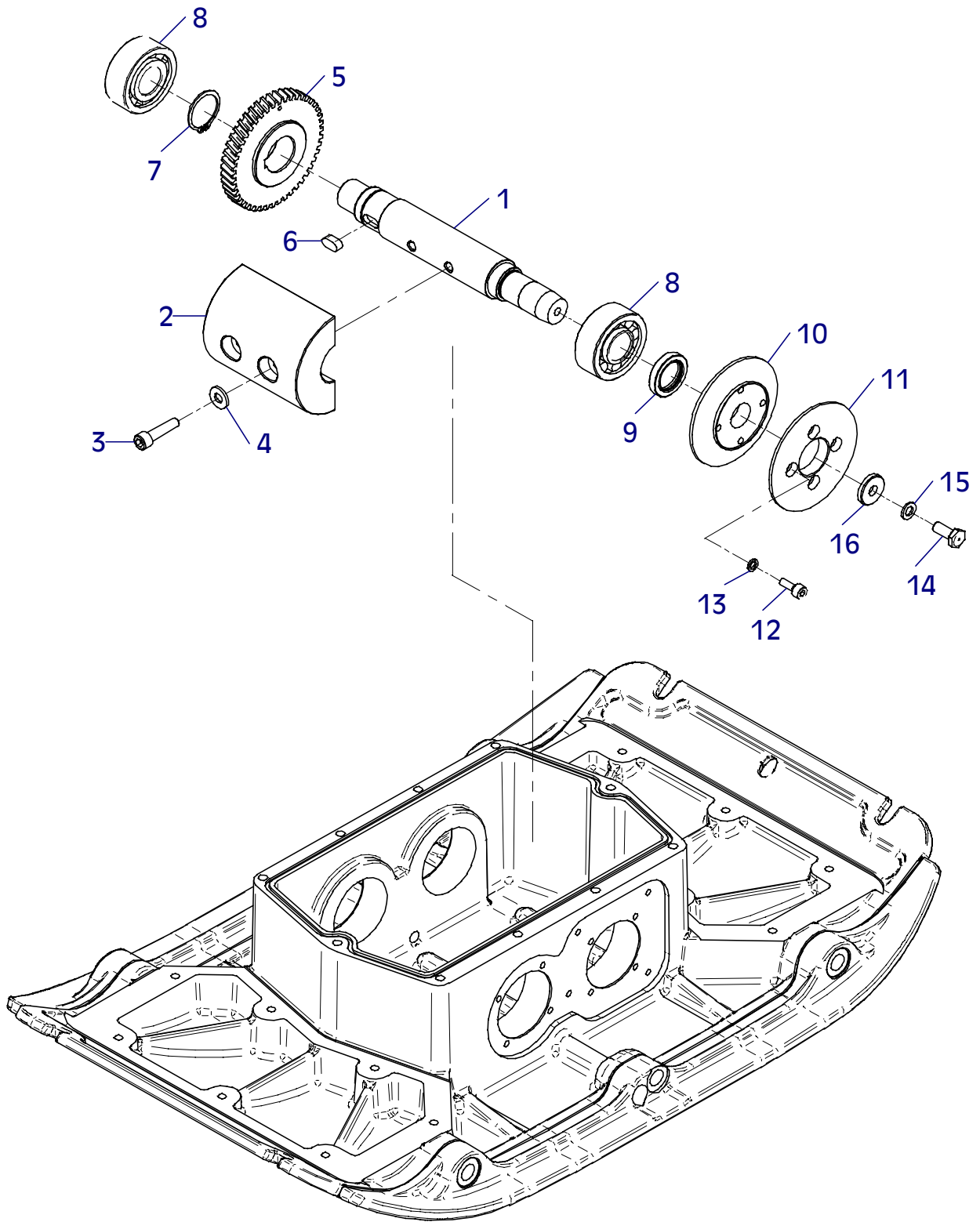

E 3370-0609

Position Ref.No. Repère Posizione Posicion	Menge Quantity Quantité Quantità Cantidad	Teile-Nr. Part-No. No. Référence Nr. d'Ordine No. Referenzia	Hinweis Hints Indications Indicazione Indicaciones	Position Ref. No. Repère Posizione Posicion	Menge Quantity Quantité Quantità Cantidad	Teile-Nr. Part-No. No. Référence Nr. d'Ordine No. Referenzia	Hinweis Hints Indications Indicazione Indicaciones
1	1	11000669					
2	1	11000671					
3	2	21000358	DIN912-M10x40-10.9				
4	2	25025245					
5	1	11000345					
6	1	25001045					
7	1	25034006	DIN471-A35x1,5				
8	1	25035003	DIN472-l62x2				
9	1	11000346					
10	1	21000228					
11	1	25034018	DIN471-A75x2,5				
12	2	25001144					
13	1	21000382					
14	1	25048003	DIN125-A10,5				
15	1	25035011	DIN472-l20				
16	1	11000670					
17	1	11000355					
18	1	25027004	DIN914-M8x16				
19	1	25035025	DIN472-l24x1,2				
20	2	25001705					
21	1	25034032	DIN471-A9x1				
22	1	10017370					
23	1	20013270					

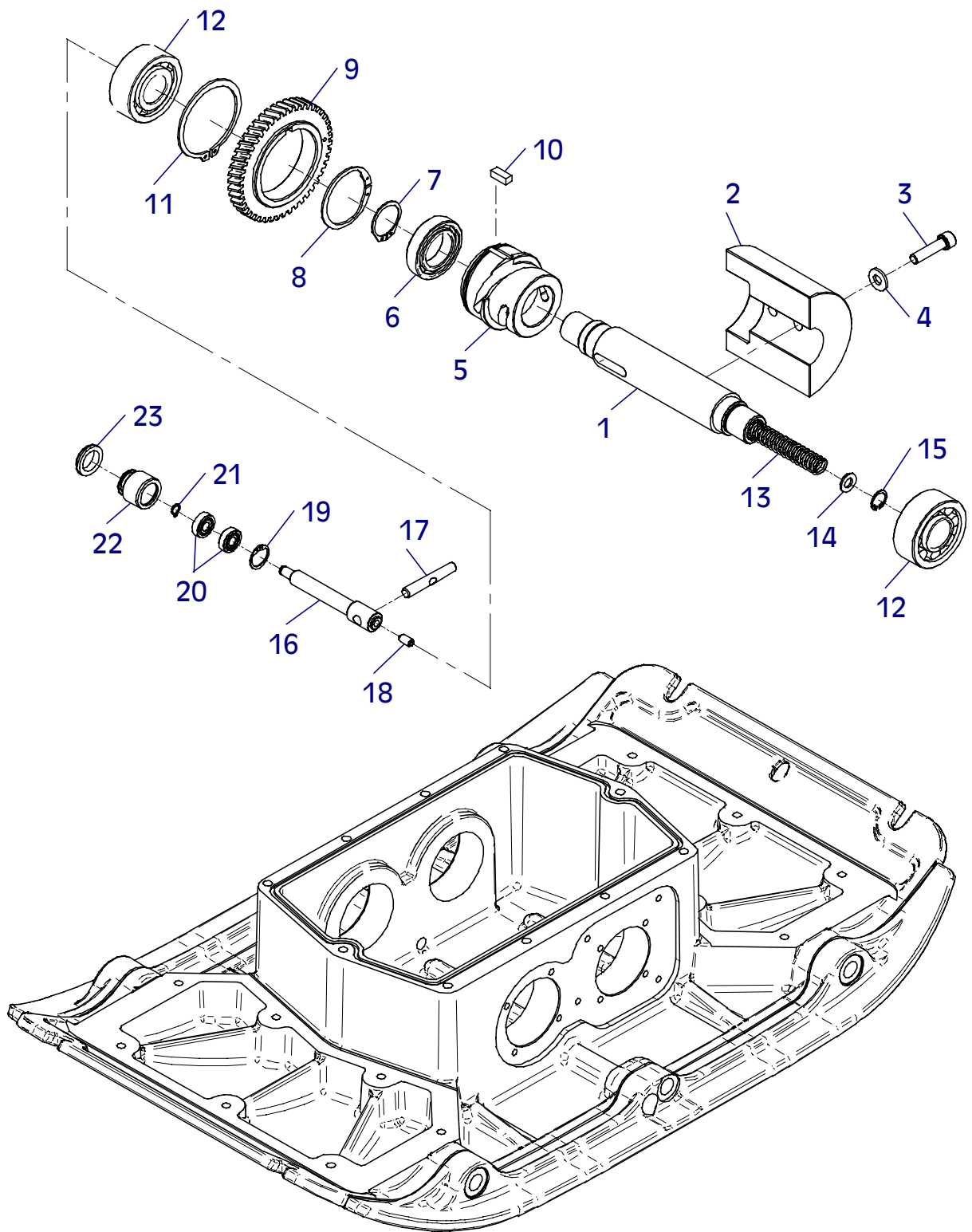

E 3370-0609

E 3371-0609

Position Ref.No. Repère Posizione Posicion	Menge Quantity Quantité Quantita Cantidad	Teile-Nr. Part-No. No. Référence Nr. d'Ordine No. Referenzia	Hinweis Hints Indications Indicazione Indicaciones	Position Ref. No. Repère Posizione Posicion	Menge Quantity Quantité Quantita Cantidad	Teile-Nr. Part-No. No. Référence Nr. d'Ordine No. Referenzia	Hinweis Hints Indications Indicazione Indicaciones
1	1	11000702					
2	4	20005019					
3	4	25049006	DIN440-R14				
4	4	25038015	DIN933-M10x30				
5	4	20029033	SKM 10				
6	1	11000810					
7	2	25040030	DIN931-M10x40				
8	2	25048003	DIN125-A10,5				
9	2	20029001	VSK 10				
10	2	25031004	DIN934-M10				
11	1	10022550					
12	2	25038009	DIN933-M8x30				
13	2	25048002	DIN125-A8,4				
14	2	20029003	VSK 8				
15	2	25031003	DIN934-M8				
16	1	25009021					
17	1	11000699					
18	4	25038022	DIN933-M12x40				
19	7	20029023	SKB 12				
20	3	25031027	DIN1587-M12				

CR5

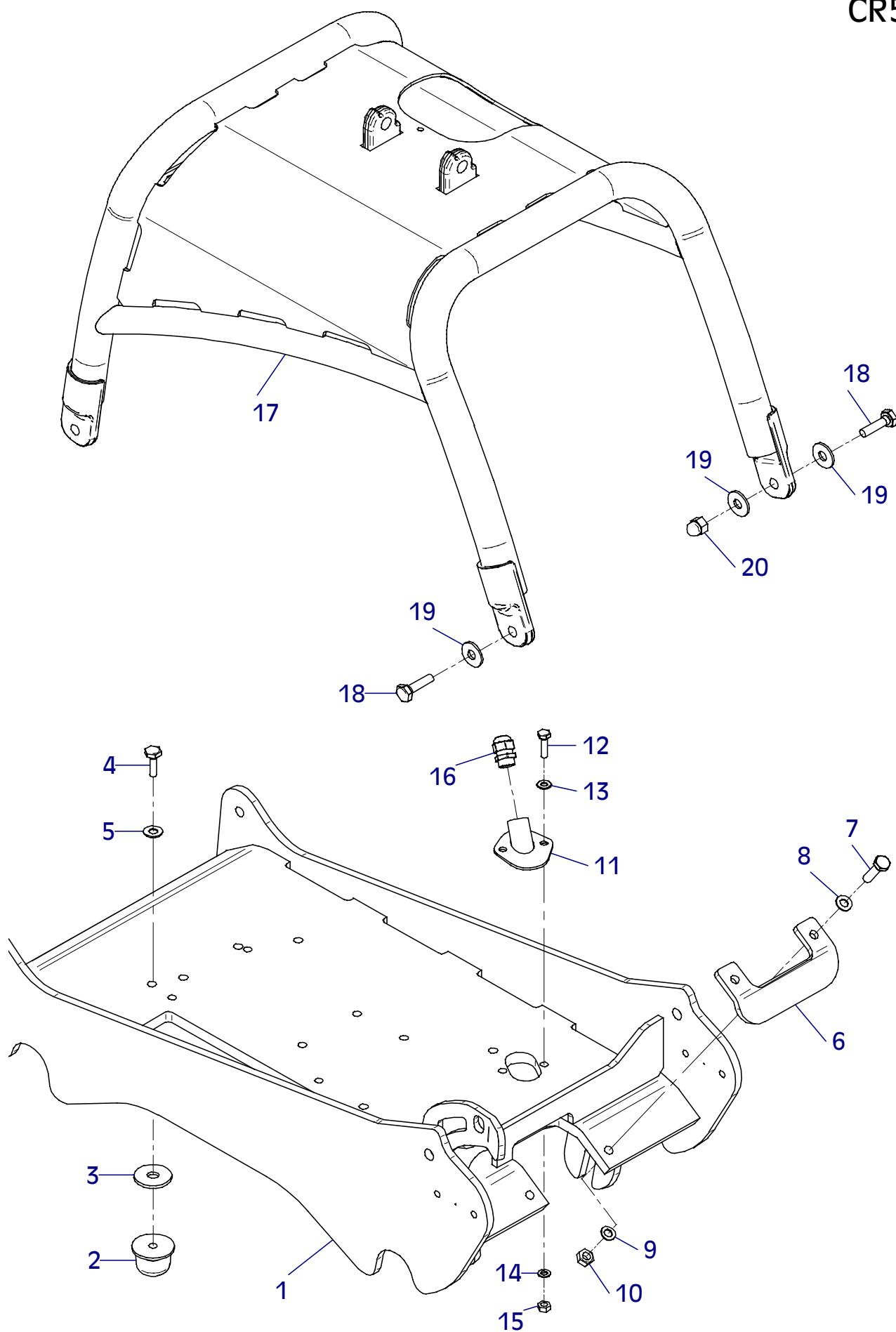

E 3371-0609

E 3383-0609

Position Ref.No. Repère Posizione Posicion	Menge Quantity Quantité Quantità Cantidad	Teile-Nr. Part-No. No. Référence Nr. d'Ordine No. Referenzia	Hinweis Hints Indications Indicazione Indicaciones	Position Ref. No. Repère Posizione Posicion	Menge Quantity Quantité Quantità Cantidad	Teile-Nr. Part-No. No. Référence Nr. d'Ordine No. Referenzia	Hinweis Hints Indications Indicazione Indicaciones
1	1	11000678					
2	4	20005019					
3	4	25049006	DIN440-R14				
4	4	25038015	DIN933-M10x30				
5	4	20029033	SKM 10				
6	1	11000810					
7	2	25040030	DIN931-M10x40				
8	2	25048003	DIN125-A10,5				
9	2	20029001	VSK 10				
10	2	25031004	DIN934-M10				
11	1	10022550					
12	2	25038009	DIN933-M8x30				
13	2	25048002	DIN125-A8,4				
14	2	20029003	VSK 8				
15	2	25031003	DIN934-M8				
16	1	25009021					
17	1	11000699					
18	4	25038022	DIN933-M12x40				
19	7	20029023	SKB 12				
20	3	25031027	DIN1587-M12				

CR5 E

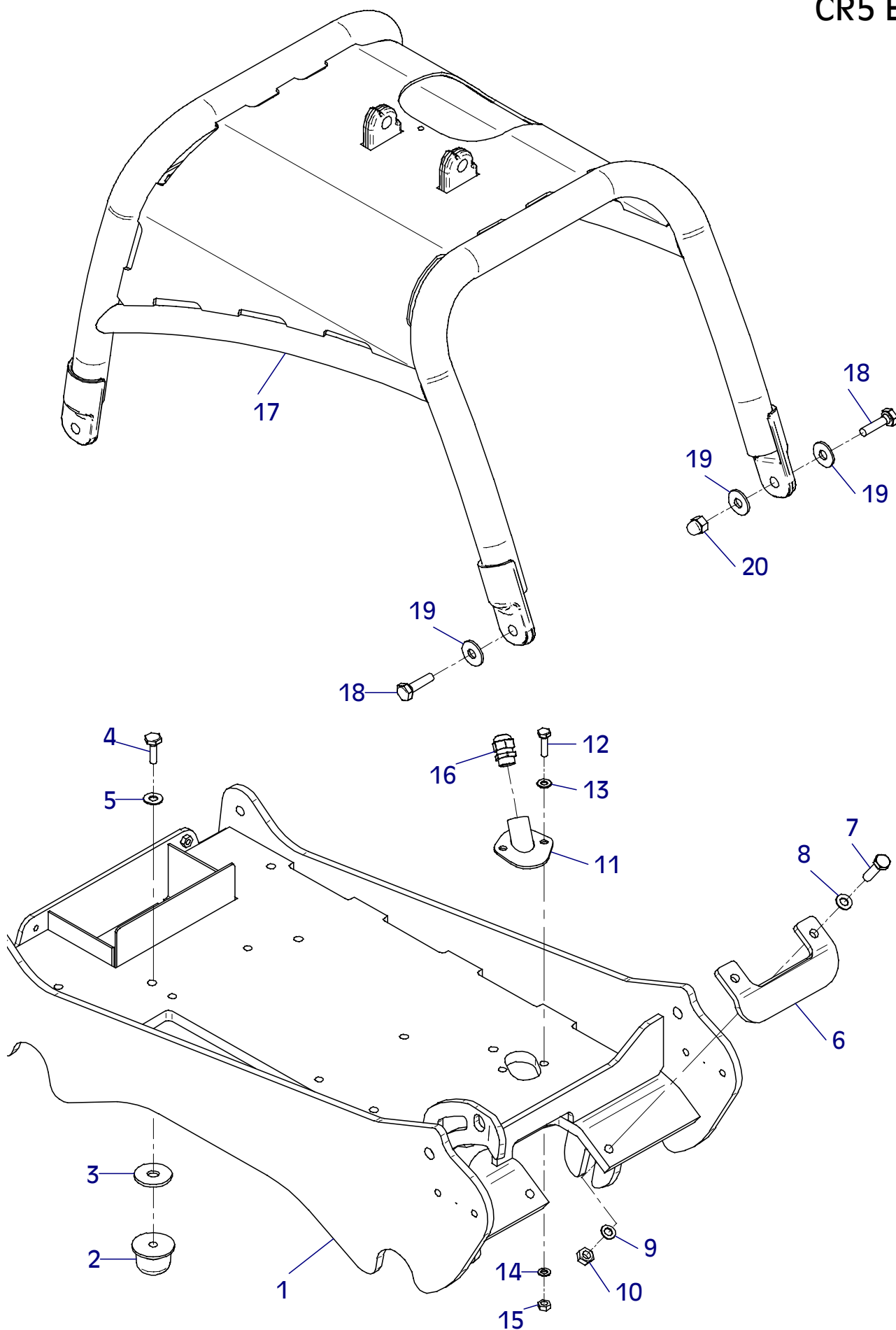

E 3383-0609

E 3378-0609

Position Ref.No. Repère Posizione Posicion	Menge Quantity Quantité Quantità Cantidad	Teile-Nr. Part-No. No. Référence Nr. d'Ordine No. Referenzia	Hinweis Hints Indications Indicazione Indicaciones	Position Ref. No. Repère Posizione Posicion	Menge Quantity Quantité Quantità Cantidad	Teile-Nr. Part-No. No. Référence Nr. d'Ordine No. Referenzia	Hinweis Hints Indications Indicazione Indicaciones
1	1	11000702					
2	4	20005019					
3	4	25049006	DIN440-R14				
4	4	25038015	DIN933-M10x30				
5	4	20029033	SKM 10				
6	1	11000810					
7	2	25040030	DIN931-M10x40				
8	2	25048003	DIN125-A10,5				
9	2	20029001	VSK 10				
10	2	25031004	DIN934-M10				
11	1	10022550					
12	2	25038009	DIN933-M8x30				
13	2	25048002	DIN125-A8,4				
14	2	20029003	VSK 8				
15	2	25031003	DIN934-M8				
16	1	25009021					
17	1	11000689					
18	4	25038022	DIN933-M12x40				
19	7	20029023	SKB 12				
20	3	25031027	DIN1587-M12				

CR5 Hd

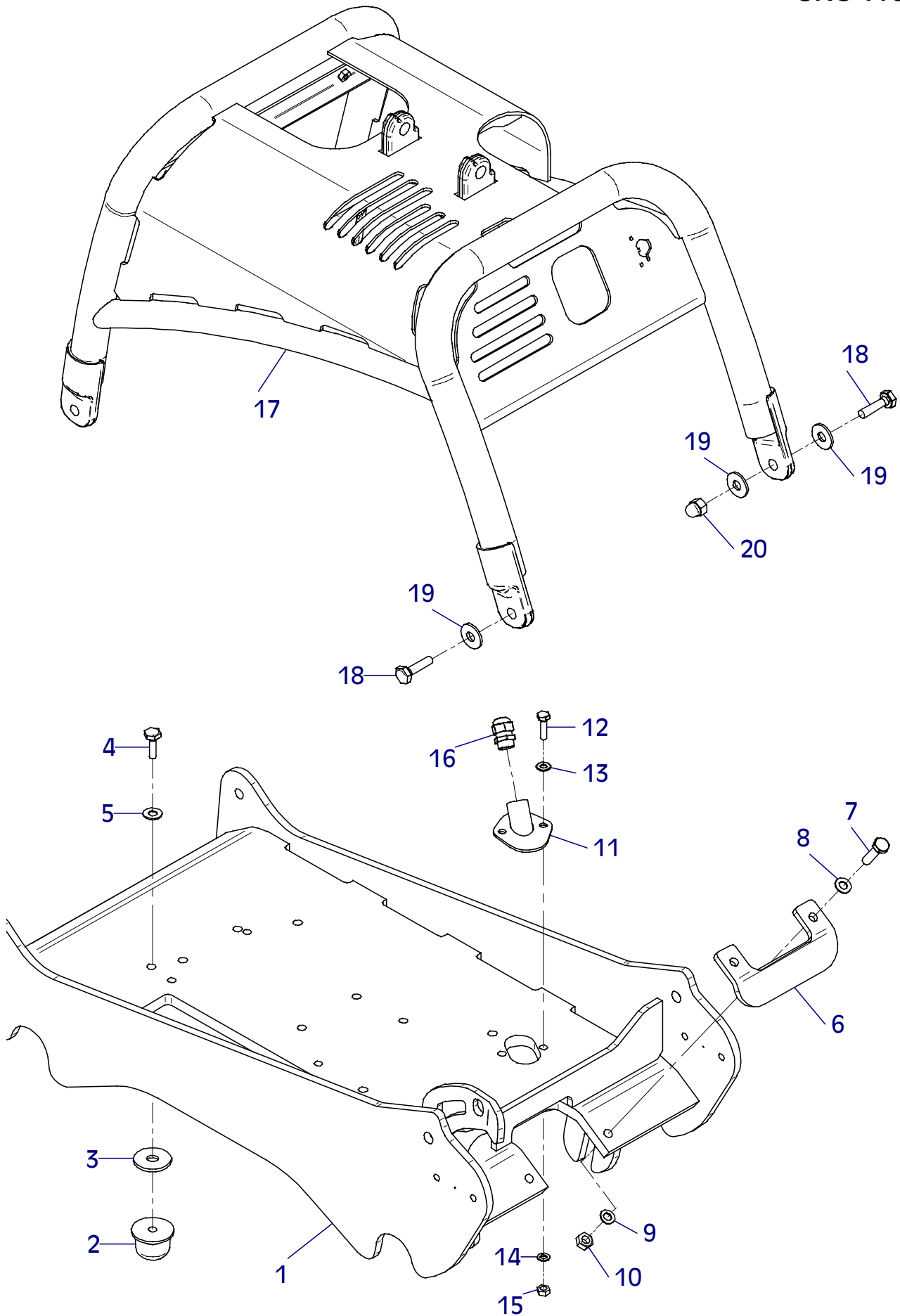

E 3378-0609

E 3372-0609

Position Ref.No. Repère Posizione Posicion	Menge Quantity Quantité Quantita Cantidad	Teile-Nr. Part-No. No. Référence Nr. d'Ordine No. Referenzia	Hinweis Hints Indications Indicazione Indicaciones	Position Ref. No. Repère Posizione Posicion	Menge Quantity Quantité Quantita Cantidad	Teile-Nr. Part-No. No. Référence Nr. d'Ordine No. Referenzia	Hinweis Hints Indications Indicazione Indicaciones
1	1	11000464					
2	4	25038006	DIN933-M8x16				
3	4	20029021	SKB 8				
4	1	10017337					
5	2	21000031					
6	2	11000148					
7	2	25040022	DIN931-M16x70				
8	2	25031017	DIN985-M16				
9	1	11000791					
10	1	25033030	ISO7380-M6x20-10.9				
11	1	25049034	DIN7349-6,4				
12	1	25048001	DIN125-A6,4				
13	1	25031012	DIN985-M6				

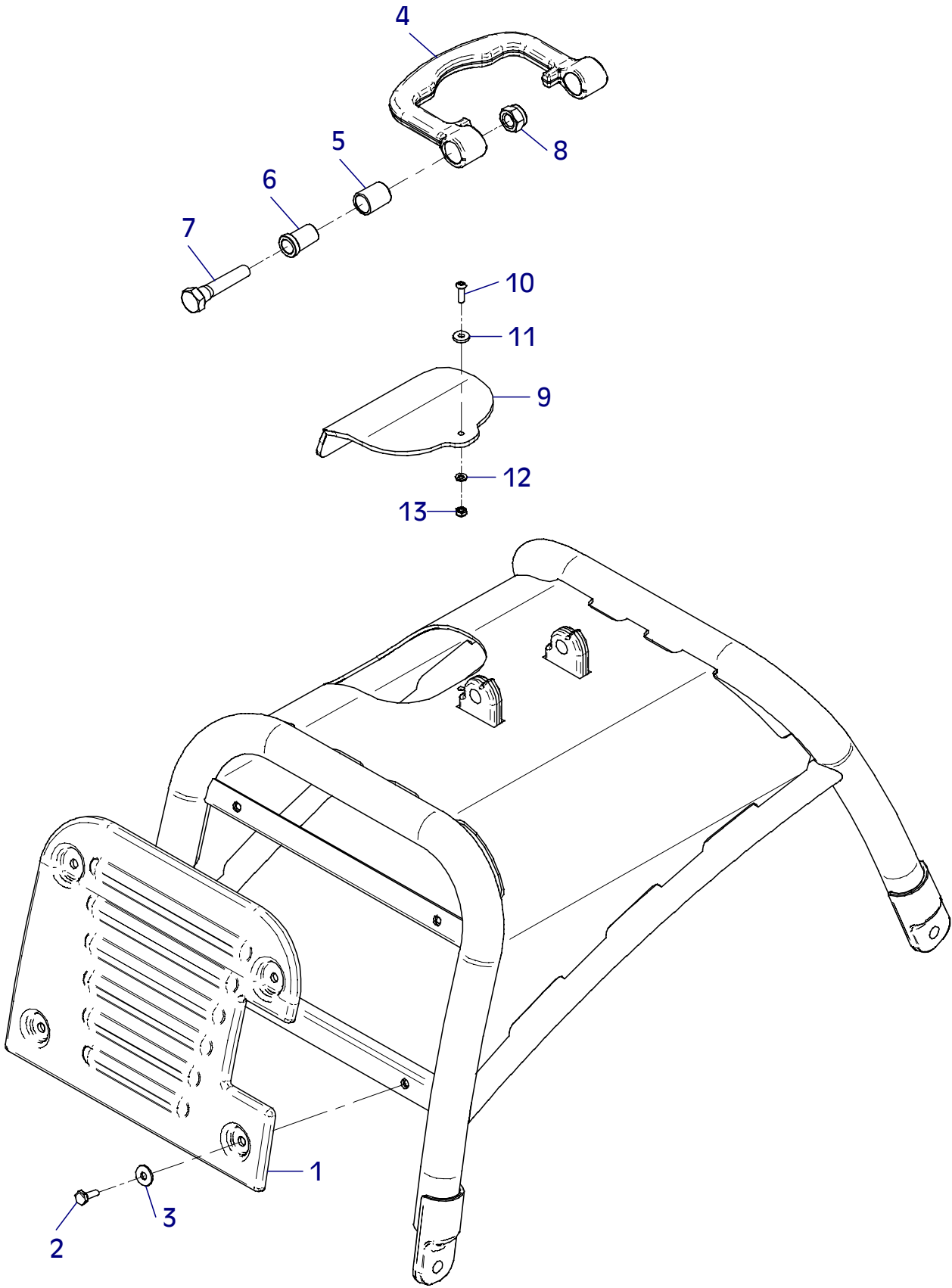

E 3379-0609

Position Ref.No. Repère Posizione Posicion	Menge Quantity Quantité Quantita Cantidad	Teile-Nr. Part-No. No. Référence Nr. d'Ordine No. Referenzia	Hinweis Hints Indications Indicazione Indicaciones	Position Ref. No. Repère Posizione Posicion	Menge Quantity Quantité Quantita Cantidad	Teile-Nr. Part-No. No. Référence Nr. d'Ordine No. Referenzia	Hinweis Hints Indications Indicazione Indicaciones
1	1	11000530					
2	3	25038006	DIN933-M8x16				
3	3	20029021	SKB 8				
4	1	25038009	DIN933-M8x30				
5	1	20029021	SKB 8				
6	1	11000576					
7	1	25048002	DIN125-A8,4				
8	1	25031013	DIN985-M8				
9	1	11000844					
10	1	10017337					
11	2	21000031					
12	2	11000148					
13	2	25040022	DIN931-M16x70				
14	2	25031017	DIN985-M16				

CR5 Hd

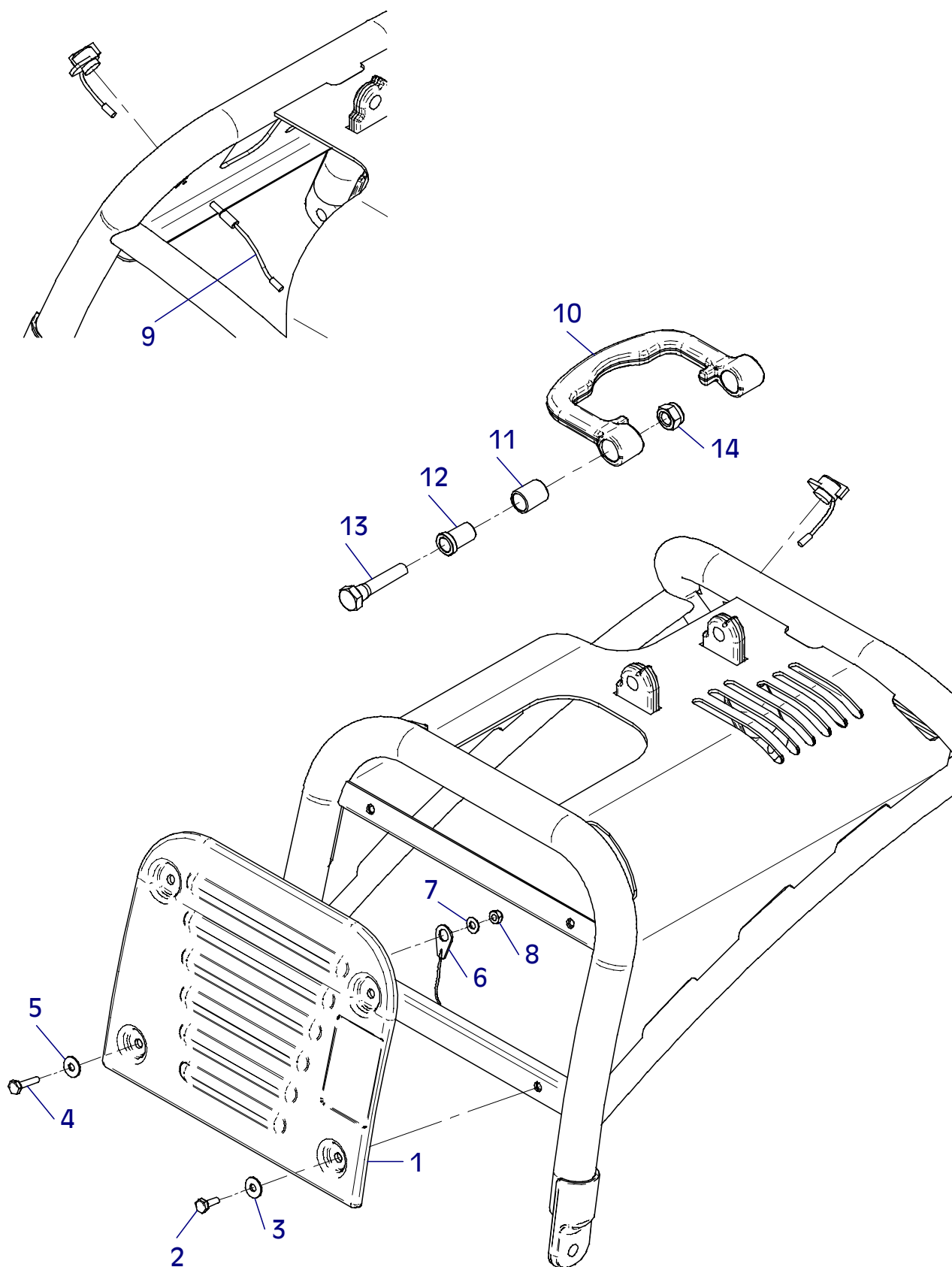

E 3373-0609

Position Ref.No. Repère Posizione Posicion	Menge Quantity Quantité Quantita Cantidad	Teile-Nr. Part-No. No. Référence Nr. d'Ordine No. Referenzia	Hinweis Hints Indications Indicazione Indicaciones	Position Ref. No. Repère Posizione Posicion	Menge Quantity Quantité Quantita Cantidad	Teile-Nr. Part-No. No. Référence Nr. d'Ordine No. Referenzia	Hinweis Hints Indications Indicazione Indicaciones
1	1	21000478					
1	1	21000552	EPA				
2	4	25038010	DIN933-M8x35				
3	4	25048002	DIN125-A8,4				
4	4	20029024					
5	4	25031003	DIN934-M8				
6	1	11000561					
7	1	20007086					
8	2	20025060					
9	1	40031336					
10	1	40031334					
11	2	25031002	DIN934-M6				
12	2	25048001	DIN125-A6,4				

CR5

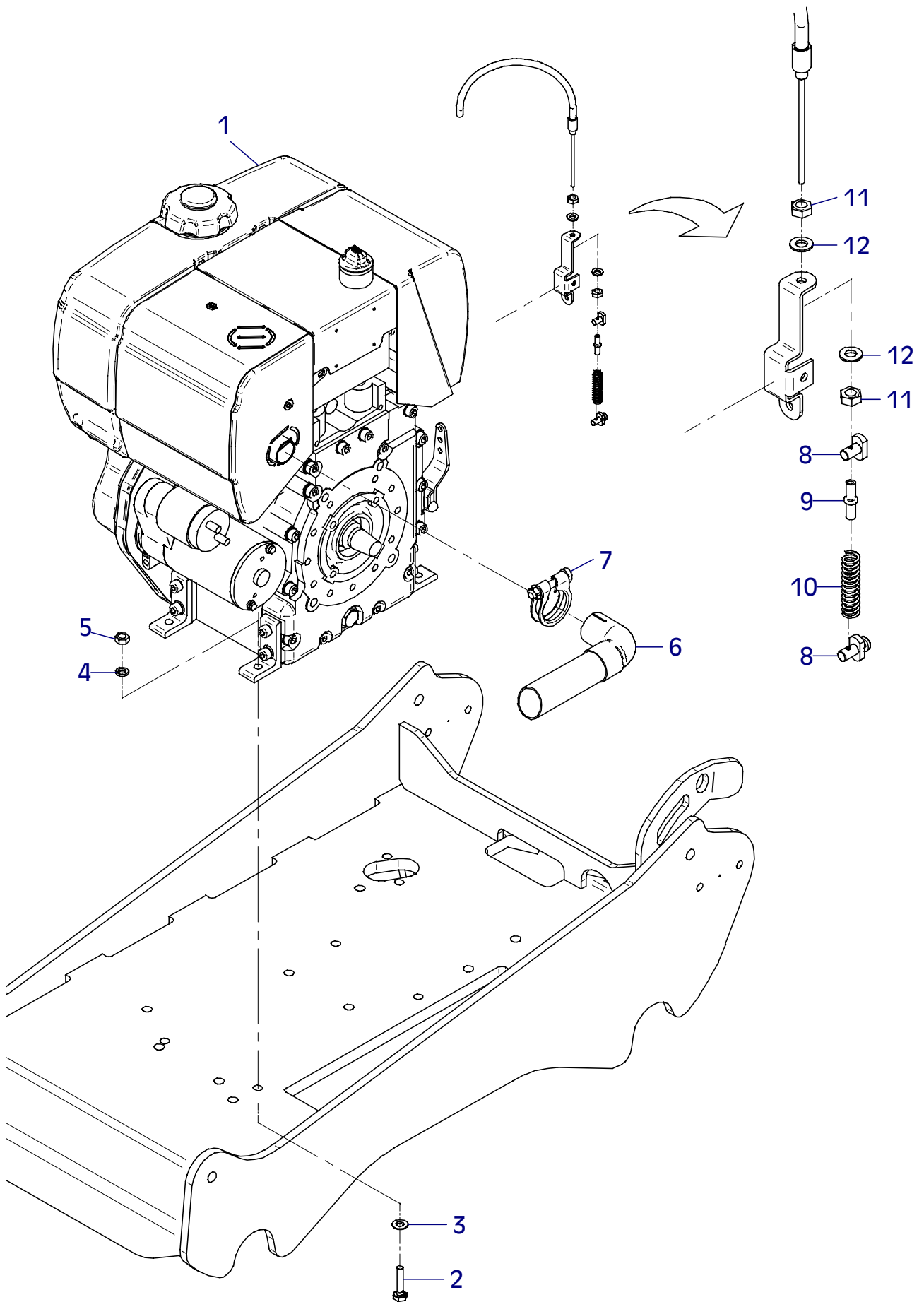

E 3373-0609

E 3384-0609

Position Ref.No. Repère Posizione Posicion	Menge Quantity Quantité Quantita Cantidad	Teile-Nr. Part-No. No. Référence Nr. d'Ordine No. Referenzia	Hinweis Hints Indications Indicazione Indicaciones	Position Ref. No. Repère Posizione Posicion	Menge Quantity Quantité Quantita Cantidad	Teile-Nr. Part-No. No. Référence Nr. d'Ordine No. Referenzia	Hinweis Hints Indications Indicazione Indicaciones
1	1	21000479					
1	1	21000551	EPA				
2	3	25038010	DIN933-M8x35				
3	3	25048002	DIN125-A8,4				
4	3	20029024					
5	3	25031003	DIN934-M8				
6	1	11000561					
7	1	20007086					
8	2	20025060					
9	1	40031336					
10	1	40031334					
11	2	25031002	DIN934-M6				
12	2	25048001	DIN125-A6,4				
13	1	25038012	DIN933-M8x45				
14	3	25048002	DIN125-A8,4				
15	1	20029024					
16	1	25031003	DIN934-M8				
17	1	25031013	DIN985-M8				

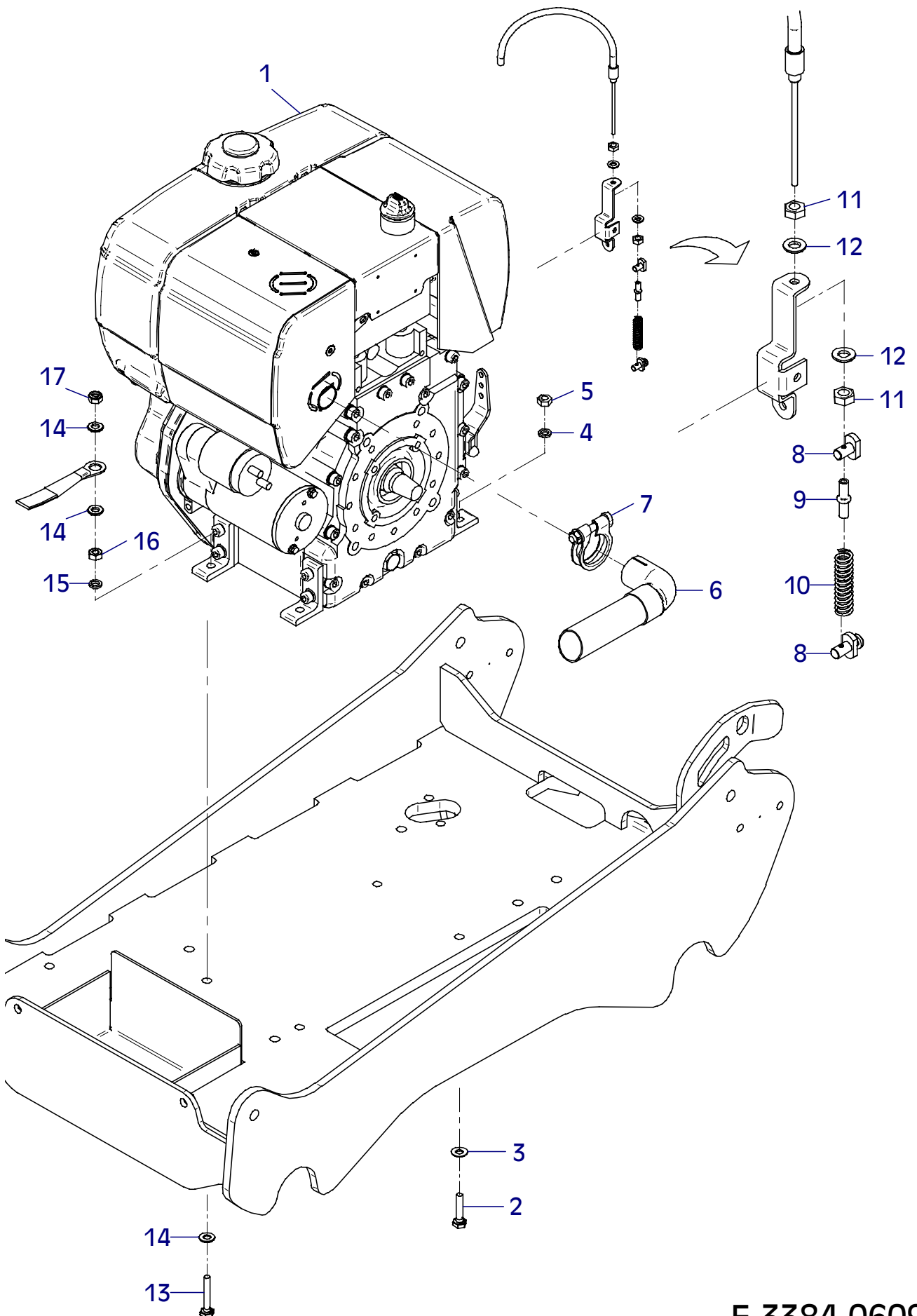

E 3374-0609

Position Ref.No. Repère Posizione Posicion	Menge Quantity Quantité Quantita Cantidad	Teile-Nr. Part-No. No. Référence Nr. d'Ordine No. Referenzia	Hinweis Hints Indications Indicazione Indicaciones	Position Ref. No. Repère Posizione Posicion	Menge Quantity Quantité Quantita Cantidad	Teile-Nr. Part-No. No. Référence Nr. d'Ordine No. Referenzia	Hinweis Hints Indications Indicazione Indicaciones
1	1	11000732					
2	4	20022013	Tensilock M10x20				
3	1	21000464					
4	1	21000042	DIN912-M8x55-12.9				
5	1	20029003	VSK 8				
6	1	20026475					
7	1	21000519					
8	1	11000544					
9	4	25044009	DIN912-M8x45				
10	4	20029011	VSKZ 8				
11	1	21000334					
12	1	25008017	DIN7603-22x27x1,5				
13	1	21000518					
14	1	11000635					
15	1	25038009	DIN933-M8x30				
16	1	25048002	DIN125-A8,4				
17	1	20022002	Tensilock M8				
18	1	25038007	DIN933-M8x20				
19	1	25048002	DIN125-A8,4				
20	1	20022002	Tensilock M8				

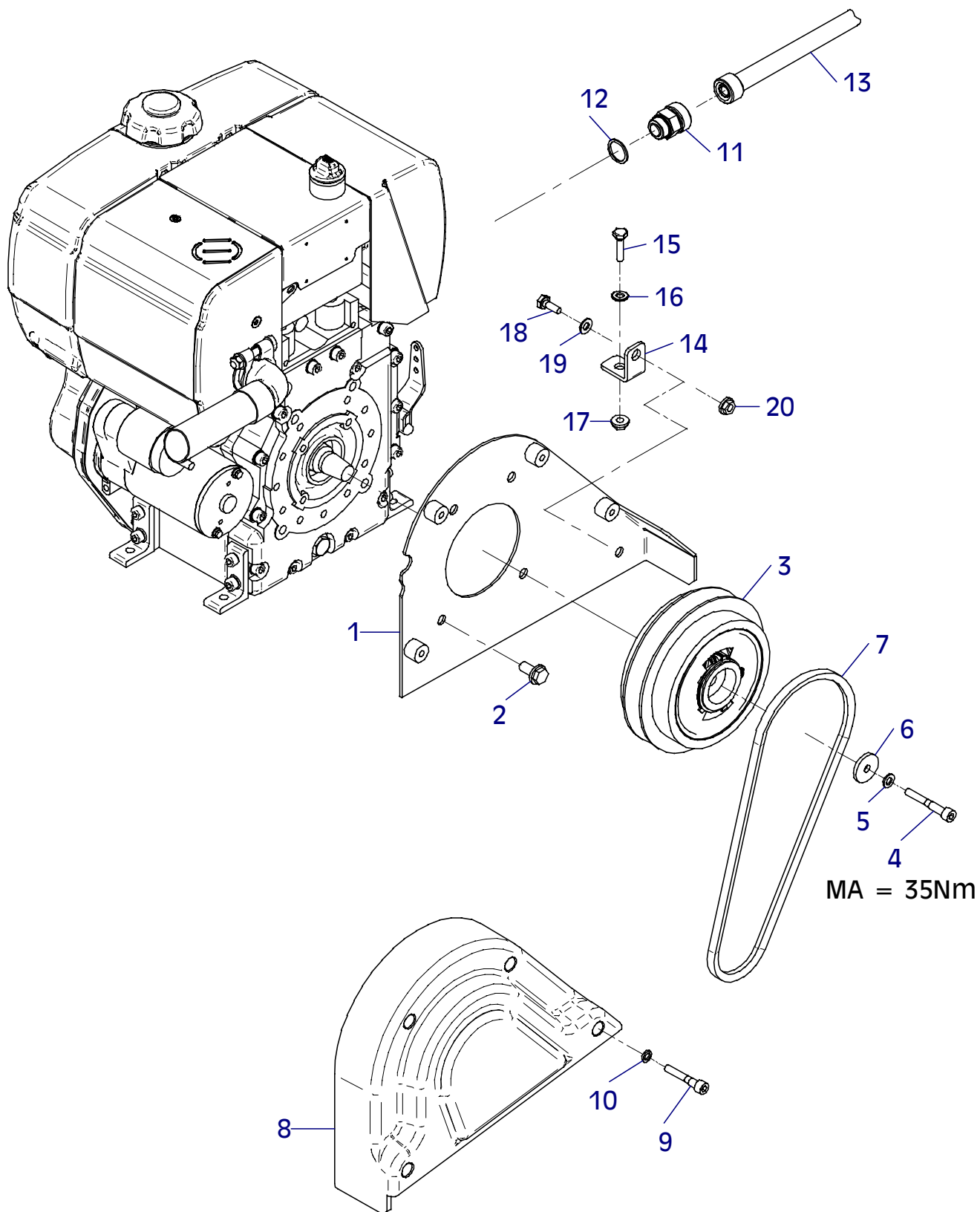

E 3385-0609

Position Ref.No. Repère Posizione Posicion	Menge Quantity Quantité Cantidad	Teile-Nr. Part-No. No. Référence Nr. d'Ordine No. Referenzia	Hinweis Hints Indications Indicazione Indicaciones	Position Ref. No. Repère Posizione Posicion	Menge Quantity Quantité Cantidad	Teile-Nr. Part-No. No. Référence Nr. d'Ordine No. Referenzia	Hinweis Hints Indications Indicazione Indicaciones
1	1	11000847					
2	4	20022013	Tensilock M10x20				
3	1	21000464					
4	1	21000042	DIN912-M8x55-12.9				
5	1	20029003	VSK 8				
6	1	20026475					
7	1	21000519					
8	1	11000544					
9	4	25044009	DIN912-M8x45				
10	4	20029011	VSKZ 8				
11	1	21000334					
12	1	25008017	DIN7603-22x27x1,5				
13	1	21000518					
14	1	11000635					
15	1	25038009	DIN933-M8x30				
16	1	25048002	DIN125-A8,4				
17	1	20022002	Tensilock M8				
18	1	25038007	DIN933-M8x20				
19	1	25048002	DIN125-A8,4				
20	1	20022002	Tensilock M8				

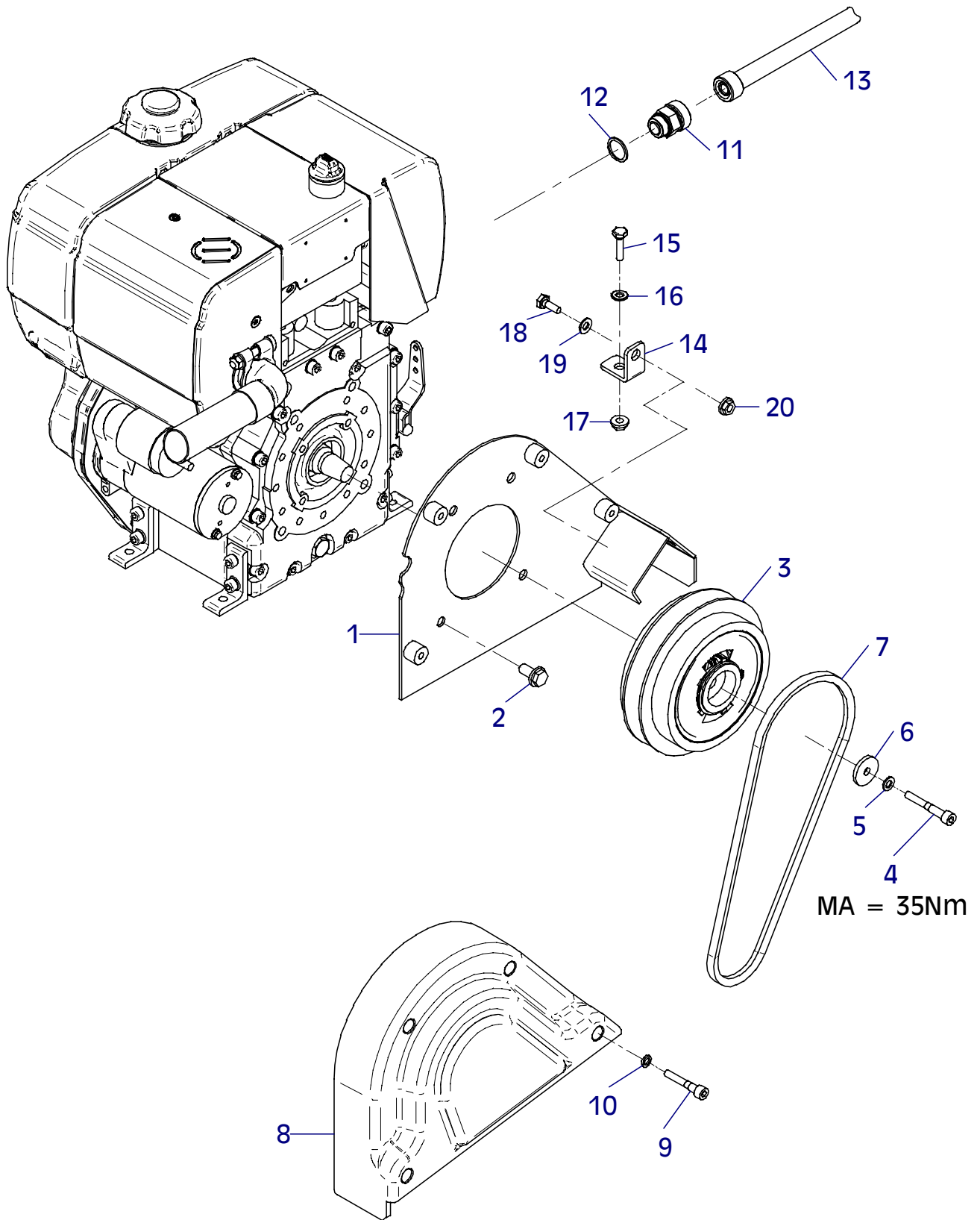

E 3375-0609

Position Ref.No. Repère Posizione Posicion	Menge Quantity Quantité Quantita Cantidad	Teile-Nr. Part-No. No. Référence Nr. d'Ordine No. Referenzia	Hinweis Hints Indications Indicazione Indicaciones	Position Ref. No. Repère Posizione Posicion	Menge Quantity Quantité Quantita Cantidad	Teile-Nr. Part-No. No. Référence Nr. d'Ordine No. Referenzia	Hinweis Hints Indications Indicazione Indicaciones
1	1	21000464					
2	2	20002548					
3	2	20002269					
4	2	21000151					
5	3	21000538					

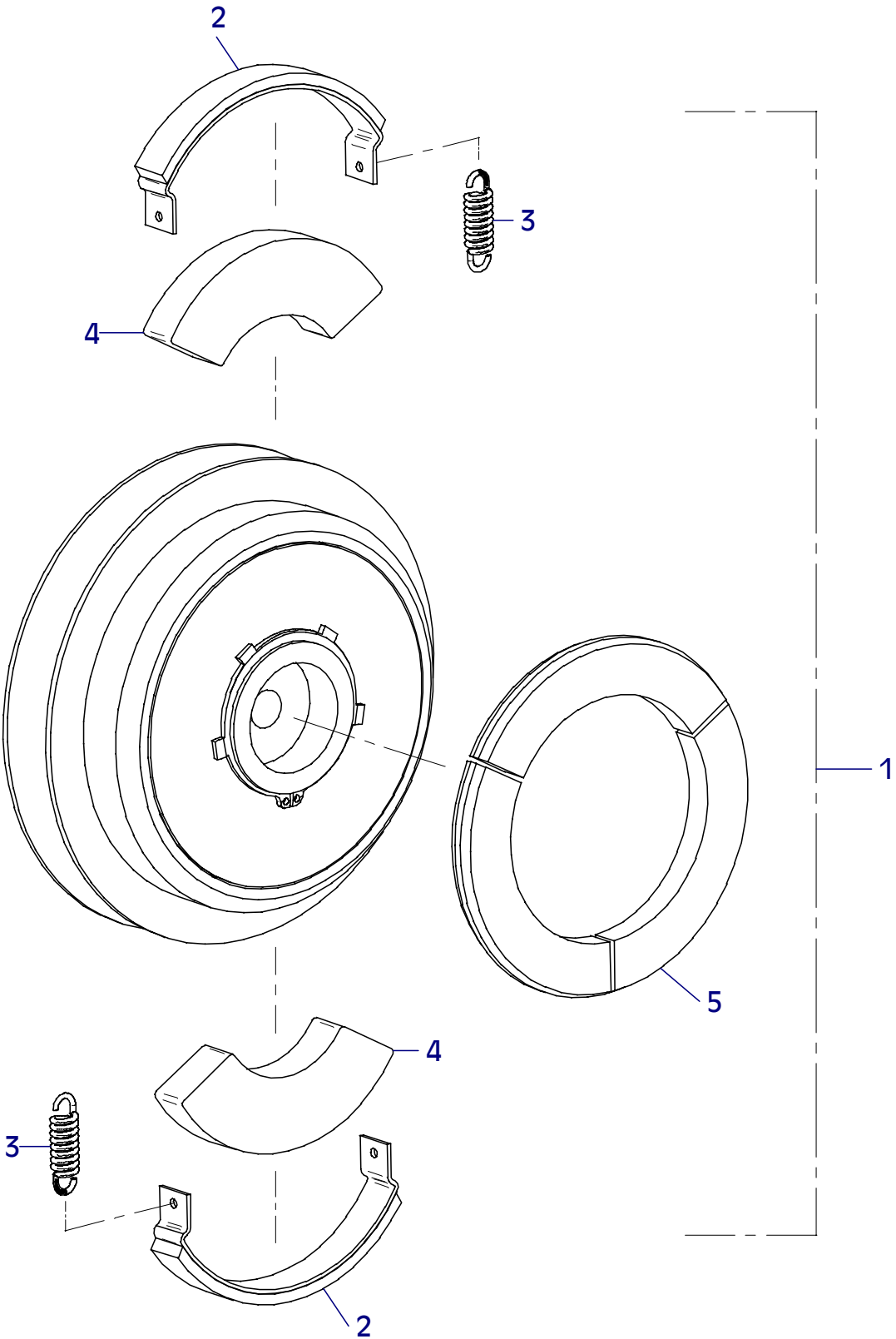

E 3386-0609

Position Ref.No. Repère Posizione Posicion	Menge Quantity Quantité Quantita Cantidad	Teile-Nr. Part-No. No. Référence Nr. d'Ordine No. Referenzia	Hinweis Hints Indications Indicazione Indicaciones	Position Ref. No. Repère Posizione Posicion	Menge Quantity Quantité Quantita Cantidad	Teile-Nr. Part-No. No. Référence Nr. d'Ordine No. Referenzia	Hinweis Hints Indications Indicazione Indicaciones
1	1	20031558					
2	1	11000597					
3	2	11000596					
4	2	11000595					
5	1	11000594					
6	1	11000627					
7	1	10001457					
8	1	11000677					
9	2	25038009	DIN933-M8x30				
10	2	25038007	DIN933-M8x20				
11	4	20029021	SKB 8				
12	1	21000354					
13	1	20007004					
14	1	25044005	DIN912-M8x20				
15	1	20029003	VSK 8				
16	1	11000843					
17	1	21000545					
18	2	21000550					
19	2	25031011	DIN985-M4				

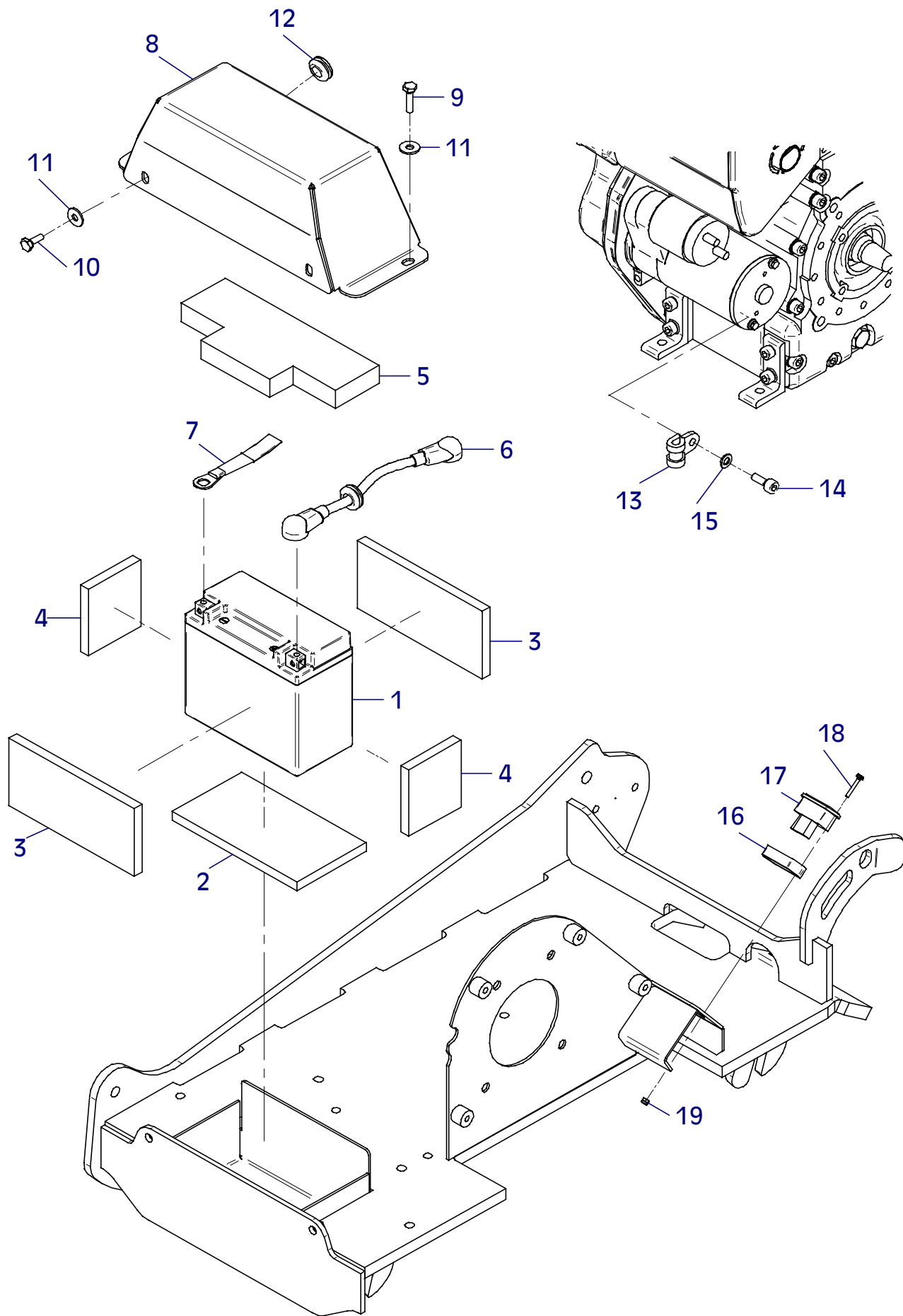

E 3380-0609

Position Ref.No. Repère Posizione Posicion	Menge Quantity Quantité Quantita Cantidad	Teile-Nr. Part-No. No. Référence Nr. d'Ordine No. Referenzia	Hinweis Hints Indications Indicazione Indicaciones	Position Ref. No. Repère Posizione Posicion	Menge Quantity Quantité Quantita Cantidad	Teile-Nr. Part-No. No. Référence Nr. d'Ordine No. Referenzia	Hinweis Hints Indications Indicazione Indicaciones
1	1	20001230					
2	2	10016212					
3	4	25040014	DIN931-M10x65				
4	4	25048003	DIN125-A10,5				
5	4	25049020	DIN7349-10,5				
6	4	20029025					
7	4	25031004	DIN934-M10				
8	1	20026580					
9	1	20007007					
10	1	25038002	DIN933-M6x16				
11	1	20029007	VSK 6				
12	1	25048001	DIN125-A6,4				
13	1	20026384					
14	2	20026389					
15	1	21000335					
16	1	20026383					

CR5 Hd

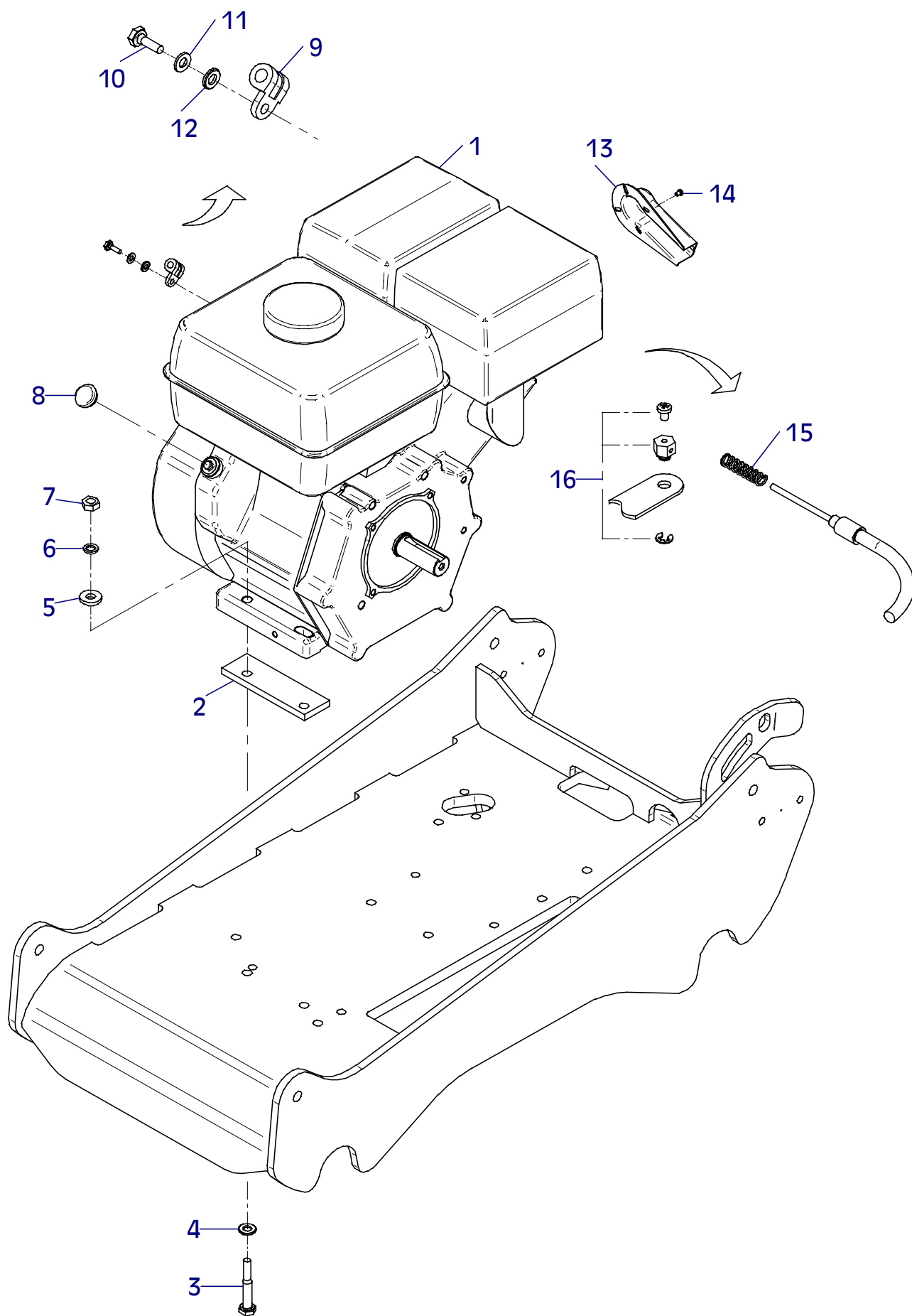

E 3380-0609

E 3381-0609

Position Ref.No. Repère Posizione Posicion	Menge Quantity Quantité Quantità Cantidad	Teile-Nr. Part-No. No. Référence Nr. d'Ordine No. Referenzia	Hinweis Hints Indications Indicazione Indicaciones	Position Ref. No. Repère Posizione Posicion	Menge Quantity Quantité Quantità Cantidad	Teile-Nr. Part-No. No. Référence Nr. d'Ordine No. Referenzia	Hinweis Hints Indications Indicazione Indicaciones
1	1	11000734					
2	4	25047017	DIN7991-M8x20				
3	4	25005003	DIN6798-V8,4				
4	1	21000465					
5	1	10016954					
6	1	21000543					
7	1	25044501	DIN912-M8x30-10.9				
8	1	20029011	VSKZ 8				
9	1	11000845					
10	1	11000544					
11	4	25044009	DIN912-M8x45				
12	4	20029011	VSKZ 8				
13	1	11000635					
14	1	25038009	DIN933-M8x30				
15	1	25048002	DIN125-A8,4				
16	1	20022002	Tensilock M8				
17	1	25038007	DIN933-M8x20				
18	1	25048002	DIN125-A8,4				
19	1	20022002	Tensilock M8				
20	1	21000518					
21	1	20026204					
22	1	25008011	DIN7603-12x18x1,5				

CR5 Hd

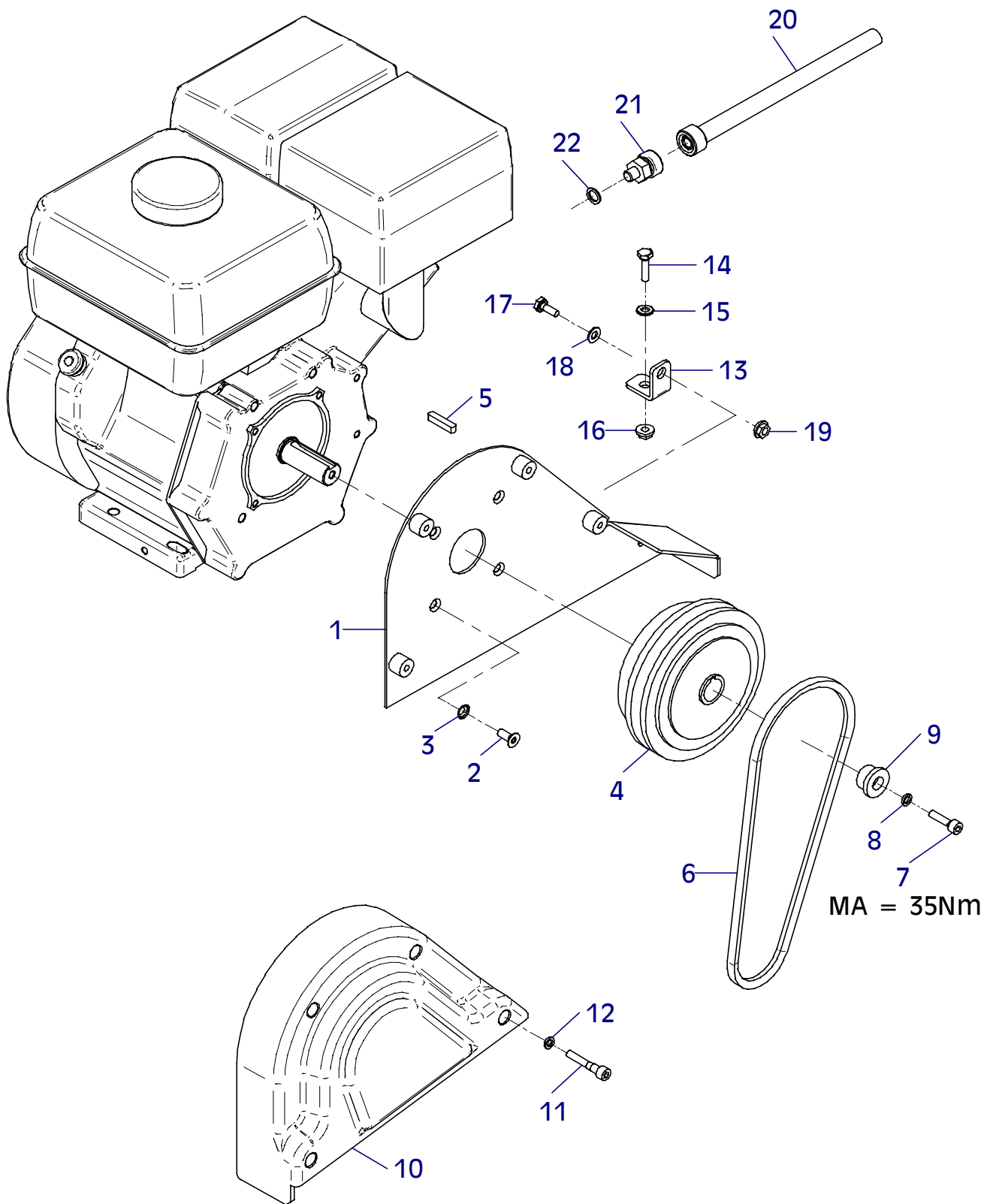

E 3382-0609

Position Ref.No. Repère Posizione Posicion	Menge Quantity Quantité Quantità Cantidad	Teile-Nr. Part-No. No. Référence Nr. d'Ordine No. Referenzia	Hinweis Hints Indications Indicazione Indicaciones	Position Ref. No. Repère Posizione Posicion	Menge Quantity Quantité Quantità Cantidad	Teile-Nr. Part-No. No. Référence Nr. d'Ordine No. Referenzia	Hinweis Hints Indications Indicazione Indicaciones
1	1	21000465					
2	2	20002548					
3	2	20002269					
4	2	21000151					
5	3	21000431					

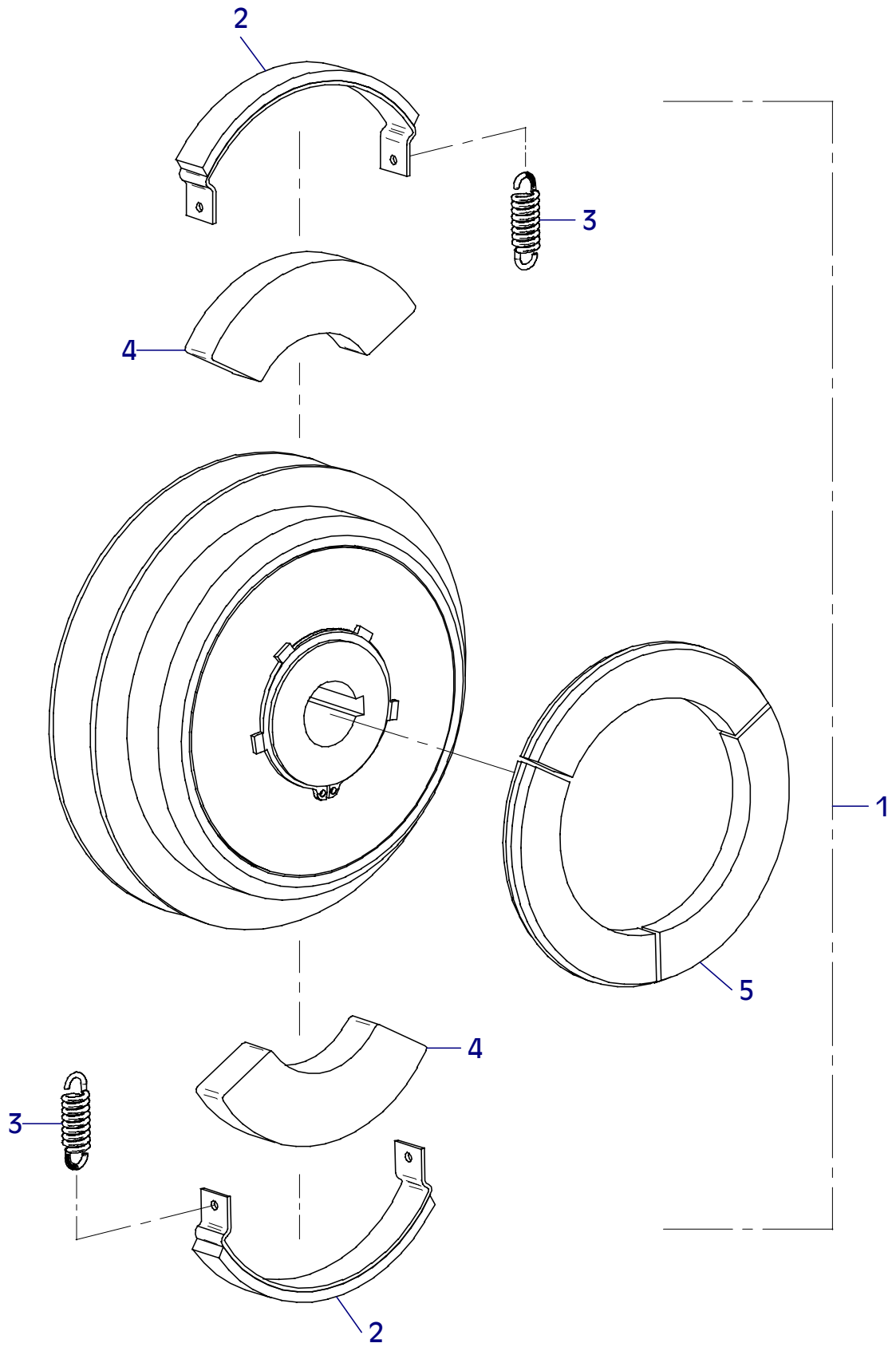

E 3376-0609

Position Ref.No. Repère Posizione Posicion	Menge Quantity Quantité Cantidad	Teile-Nr. Part-No. No. Référence Nr. d'Ordine No. Referenzia	Hinweis Hints Indications Indicazione Indicaciones	Position Ref. No. Repère Posizione Posicion	Menge Quantity Quantité Cantidad	Teile-Nr. Part-No. No. Référence Nr. d'Ordine No. Referenzia	Hinweis Hints Indications Indicazione Indicaciones
1	1	11000710					
2	1	11000567					
3	2	20005019					
4	2	25031004	DIN934-M10				
5	1	21000261					
6	1	20007202					
7	1	11000711					
8	2	25044016	DIN912-M10x60				
9	2	20029012	VSKZ 10				
10	1	20026493					
11	1	11000712					
12	2	25044016	DIN912-M10x60				
13	2	20029012	VSKZ 10				
14	1	20026493					
15	1	11000713					
16	4	25047021	DIN7991-M8x25				
17	4	25005003	DIN6798-V8,4				
18	1	20026481					
19	2	25025191	DIN80705-M20x1,5				
20	2	21000540					
21	2	20026492					
22	2	10016442					
23	2	25040022	DIN931-M16x70				
24	2	20029002	VSK 16				
25	4	25038008	DIN933-M8x25				
26	4	20029021	SKB 8				
27	2	20025019					

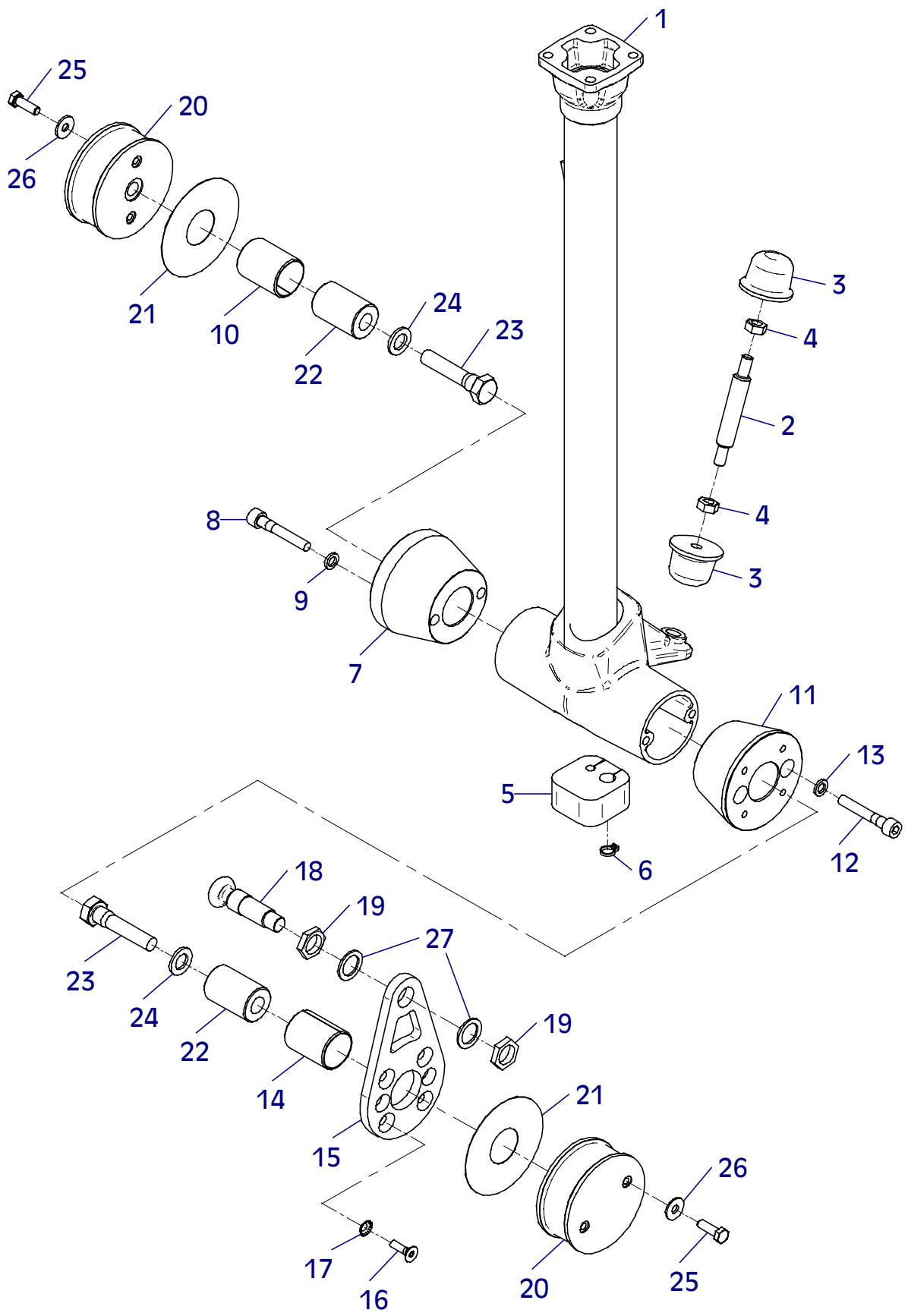

E 3376-0609

E 3377-0609

Position Ref.No. Repère Posizione Posicion	Menge Quantity Quantité Quantità Cantidad	Teile-Nr. Part-No. No. Référence Nr. d'Ordine No. Referenzia	Hinweis Hints Indications Indicazione Indicaciones	Position Ref. No. Repère Posizione Posicion	Menge Quantity Quantité Quantità Cantidad	Teile-Nr. Part-No. No. Référence Nr. d'Ordine No. Referenzia	Hinweis Hints Indications Indicazione Indicaciones
1	1	11000455					
2	4	25044006	DIN912-M8x25				
3	4	20029011	VSKZ 8				
4	1	20008067					
5	1	11000456					
6	1	20013282					
7	1	11000457					
8	1	20013284					
9	1	25035027	DIN472-I58x2				
10	1	20020119					
11	1	21000520					
12	1	21000475	Hatz				
12	1	21000477	Honda				
13	2	21000258	DIN933-M5x30				
14	2	20029006	VSK 5				
15	1	25009021					
16	1	25030002	DIN908-M14x1,5				
17	1	21000256					
18	1	25030003	DIN908-M24x1,5				
19	1	25008008	DIN7603-24x32x2				
20	2	25048017	DIN125-A5,3				

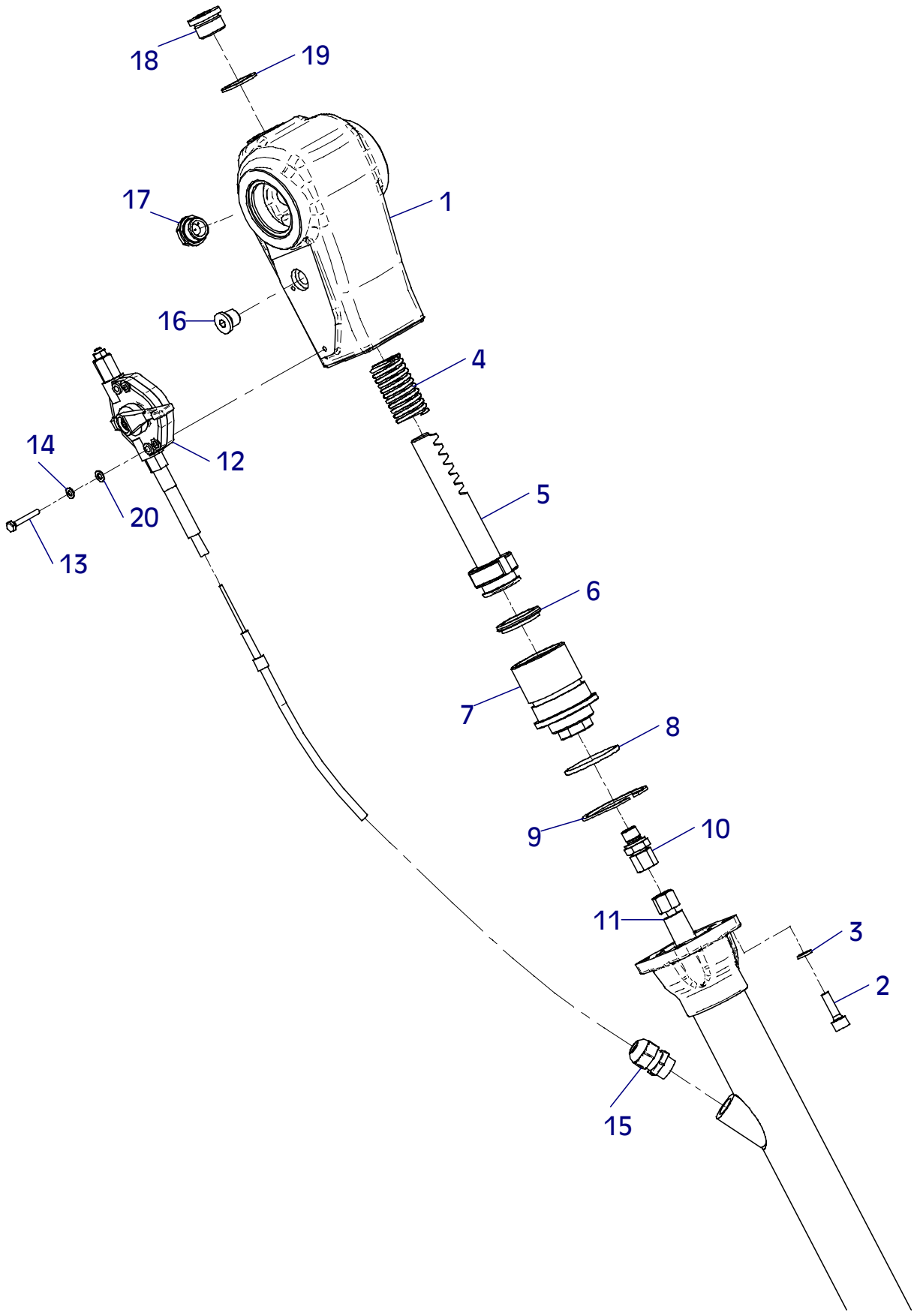

E 3377-0609

E 3337-0808

Position Ref.No. Repère Posizione Posicion	Menge Quantity Quantité Cantidad	Teile-Nr. Part-No. No. Référence Nr. d'Ordine No. Referenzia	Hinweis Hints Indications Indicazione Indicaciones	Position Ref. No. Repère Posizione Posicion	Menge Quantity Quantité Cantidad	Teile-Nr. Part-No. No. Référence Nr. d'Ordine No. Referenzia	Hinweis Hints Indications Indicazione Indicaciones
1	1	10017394					
2	2	10017397					
3	2	20013271					
4	2	25017048					
5	2	10017396					
6	2	25044035	DIN912-M12x25				
7	2	20029013	VSKZ 12				
8	2	11000056					
9	1	11000038					
10	4	25038008	DIN933-M8x25				
11	4	20029003	VSK 8				
12	2	20025593					

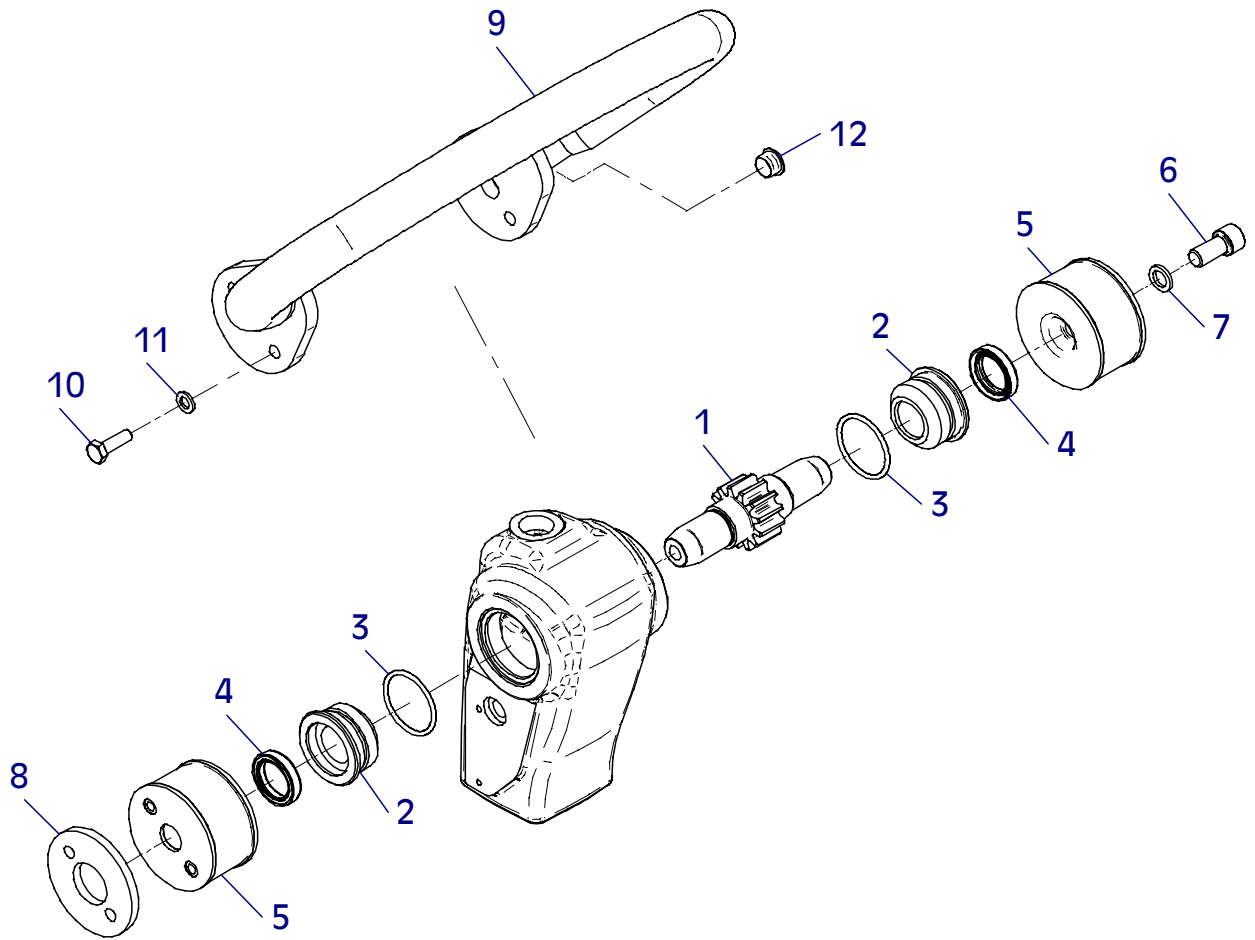

E 3337-0808

E 3387-0609

Position Ref.No. Repère Posizione Posicion	Menge Quantity Quantité Quantita Cantidad	Teile-Nr. Part-No. No. Référence Nr. d'Ordine No. Referenzia	Hinweis Hints Indications Indicazione Indicaciones	Position Ref. No. Repère Posizione Posicion	Menge Quantity Quantité Quantita Cantidad	Teile-Nr. Part-No. No. Référence Nr. d'Ordine No. Referenzia	Hinweis Hints Indications Indicazione Indicaciones
1	2	11000704	DIN931-M16x55-10.9				
2	6	21000554					
3	6	20029029					

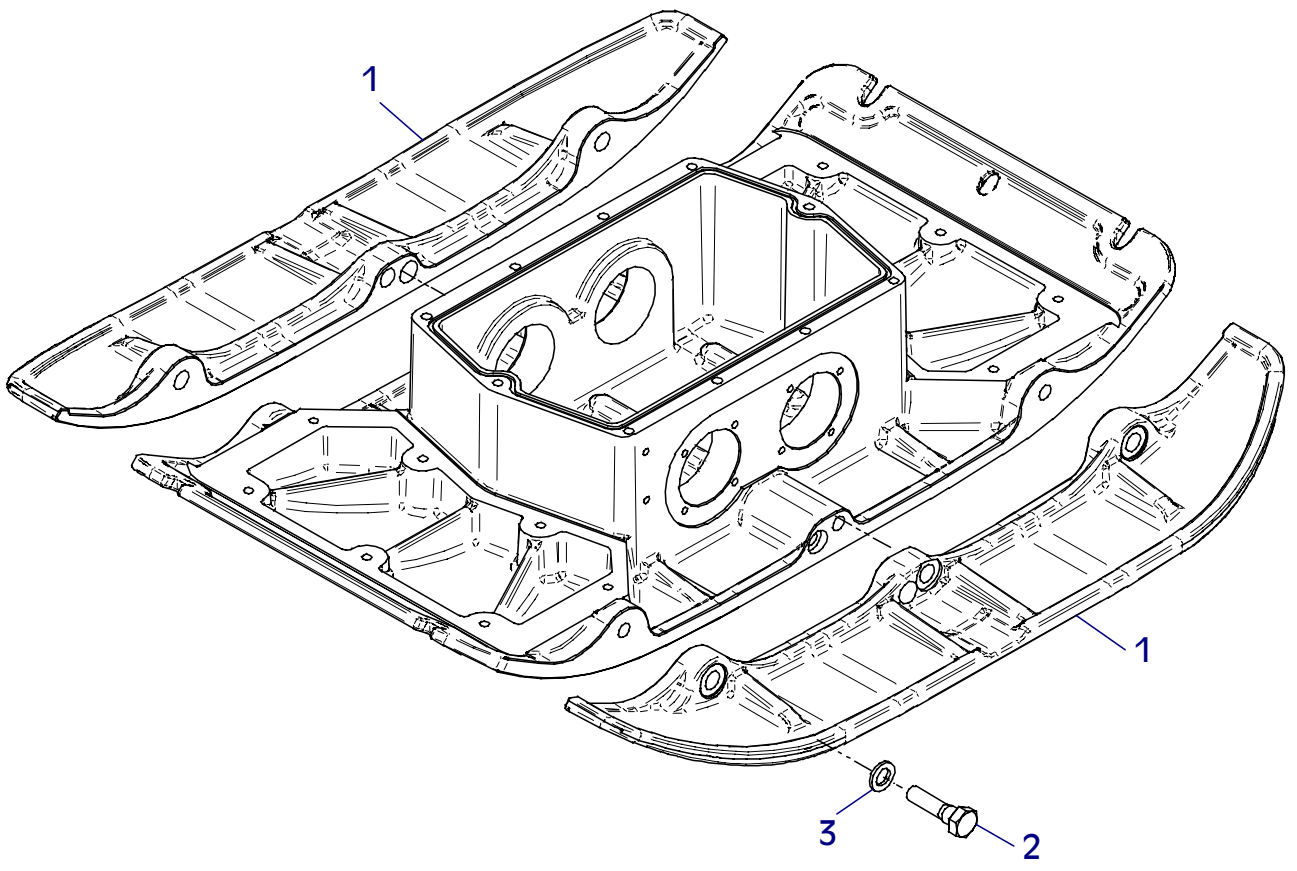

MA = 310Nm

E 3388-0609

Position Ref.No. Repère Posizione Posicion	Menge Quantity Quantité Quantita Cantidad	Teile-Nr. Part-No. No. Référence Nr. d'Ordine No. Referenzia	Hinweis Hints Indications Indicazione Indicaciones	Position Ref. No. Repère Posizione Posicion	Menge Quantity Quantité Quantita Cantidad	Teile-Nr. Part-No. No. Référence Nr. d'Ordine No. Referenzia	Hinweis Hints Indications Indicazione Indicaciones
1	1	11000841					
2	2	10017292					
3	4	25040019	DIN931-M12x55				
4	4	25048004	DIN125-A13				
5	4	20029023	SKB 12				
6	4	25031005	DIN934-M12				
7							
8							
9							
10	1	11000842					
11	2	10017292					
12	4	25040019	DIN931-M12x55				
13	4	25048004	DIN125-A13				
14	4	20029023	SKB 12				
15	4	25031005	DIN934-M12				

CR 5

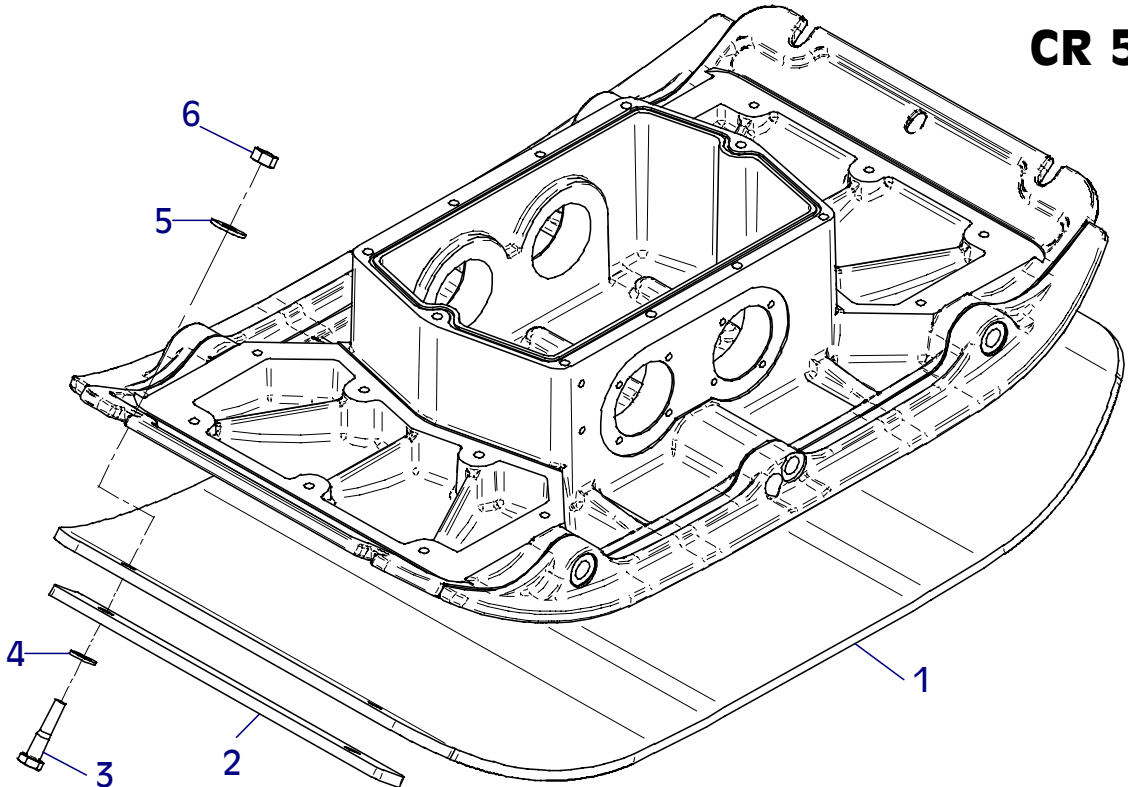

CR 5/70

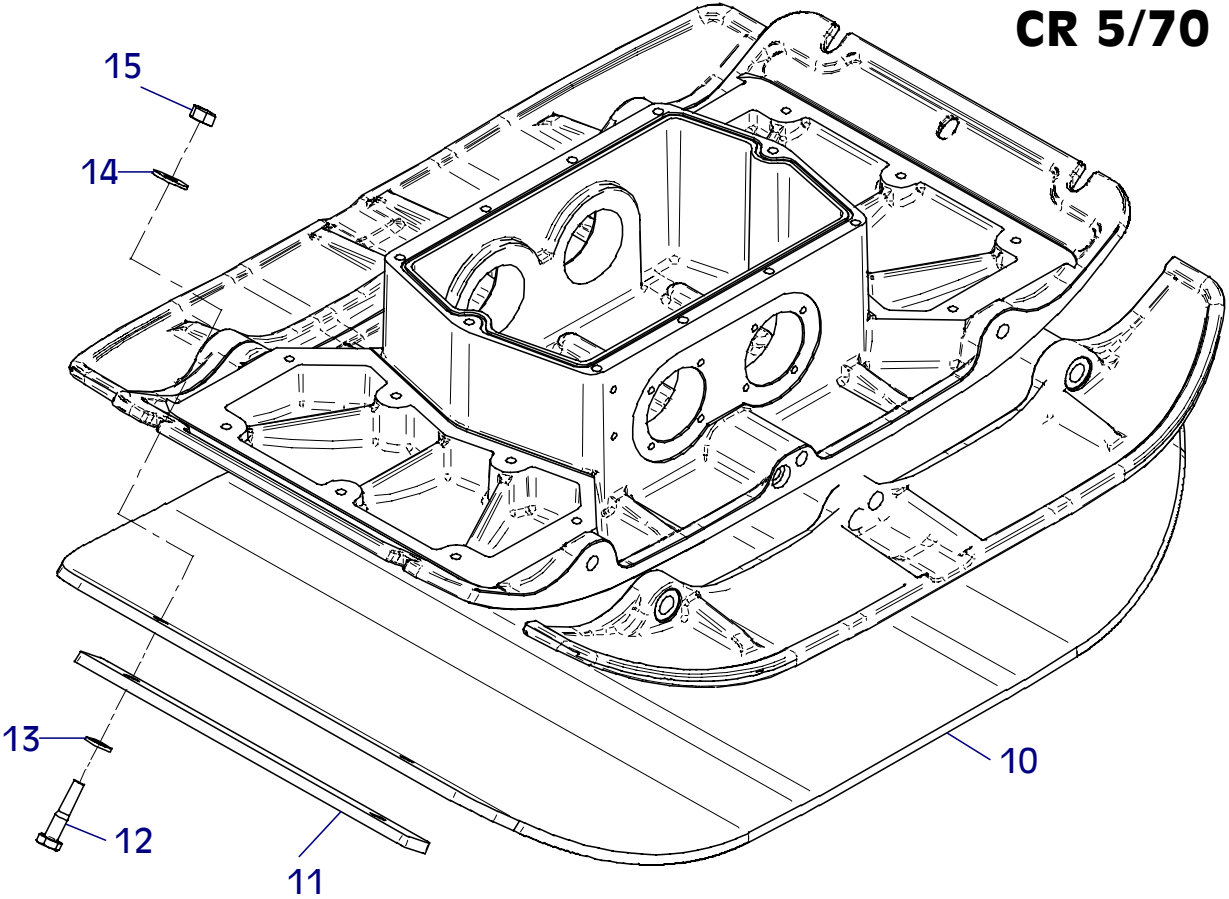

**Wenn Sie Fragen und Anregungen haben, oder sonstige Informationen benötigen,
wenden Sie sich bitte an eine der unten genannten Adressen:**

**For questions and further information refer to one of the
following addresses:**

<p>In Deutschland</p> <p>In Germany</p>	<p>WEBER Maschinenteknik GmbH Postfach 2153 57329 Bad Laasphe – Rückershausen</p> <p>Information / information: E-mail: info@webermt.de</p> <p>Ersatzteile / spare parts: E-mail: parts@webermt.de</p>	<p>Telefon / phone:</p> <p>Telefax / fax:</p> <p>Telefax / fax:</p>	<p>+49 (0) 2754 / 3980 Zentrale / switchboard</p> <p>+49 (0) 2754 / 398101 Zentrale / switchboard</p> <p>+49 (0) 2754 / 398102 Ersatzteile / spare parts direct dial</p>
<p>In Holland</p> <p>In Netherlands</p>	<p>WEBER Maschinenteknik B.V. Graafschap Hornelaan 159 6001 AC Weert</p> <p>E-mail: info@webermt.nl</p>	<p>Telefon / phone:</p> <p>Telefax / fax:</p>	<p>+31 (0) 495 / 530215</p> <p>+31 (0) 495 / 541839</p>
<p>In Frankreich</p> <p>In France</p>	<p>WEBER Technologie S.A.R.L. 26, rue d'Arsonval 69680 Chassieu</p> <p>E-mail: france@webermt.com</p>	<p>Telefon / phone:</p> <p>Telefax / fax:</p>	<p>+33 (0) 472 / 791020</p> <p>+33 (0) 472 / 791021</p>
<p>In Polen</p> <p>In Poland</p>	<p>WEBER Maschinenteknik SP.ZO.O. ul. Grodziska 7 05-830 Stara Wies / Nadarzyn</p> <p>E-mail: info@webermt.com.pl</p>	<p>Telefon / phone:</p> <p>Telefax / fax:</p>	<p>+48 (0) 22 / 7397080 +48 (0) 22 / 7397081</p> <p>+48 (0) 22 / 7397082</p>
<p>In USA, Kanada</p> <p>In USA, Canada</p>	<p>WEBER Machine (USA), Inc. 40 Johnson Ave 112 Bangor, ME 04401 USA</p> <p>E-mail: usa@webermt.com</p>	<p>Telefon / phone:</p> <p>Telefax / fax:</p>	<p>+1 (0) 207 / 9474990</p> <p>+1 (0) 207 / 9475452</p>
<p>In Südamerika</p> <p>In South America</p>	<p>WEBER Maschinenteknik do Brasil Ltda. Rua Sete de Setembro, 275 93332-470 Novo Hamburgo, RS Brasil</p> <p>E-mail: webermt@webermt.com.br</p>	<p>Telefon / phone:</p> <p>Telefax / fax:</p>	<p>+55 (0) 51 / 5873044</p> <p>+55 (0) 51 / 5872271</p>

<http://www.webermt.com>

