



ERSATZTEILLISTE

SPARE PARTS LIST

**LISTE DES PIECES
DE RECHANGE**

LISTINO RICAMBI

LISTA DE RECAMBIOS

**WYKAZ CZESCI
ZAMIENNYCH**



CR 6

0116501-0116508

Ab Masch.-Nr. 7011176



Weber Maschinenteknik GmbH

Postfach 2153, 57329 Bad Laasphe-Rückershausen

Telefon 02754 / 398-0

Telefax (02754) 398-101 (Zentrale) u. 398-102 (Ersatzteile)

EG - KONFORMITÄTSERKLÄRUNG

EC DECLARATION OF CONFORMITY/ DECLARATION DE CONFORMITE CE
DICHIARAZIONE CE DI CONFORMITA / DECLARACION CE DE CONFORMIDAD
EG-VERKLARING VAN OVEREENSTEMMING / EF-OVERENSSTEMMELSESERKAERING
DECLARACAO CE DE CONFORMIDADE / EG-FÖRSÄKRAN OM ÖVERENSSTÄMMELSE
DEKLARACJA ZGODNOŚCI

im Sinne der EG-Maschinenrichtlinie 98/37/EG und der EG Richtlinie 2000/14/EG – Geräuschemissionen

- I **Hersteller/** Make / Marque / Marca / Marca / Producent / Merk / Marca /
Tillverkare / Producent **Weber Maschinentechnik GmbH**
Im Boden 5-8,10
57334 Bad Laasphe
- II **Art /** Category / Catégorie / Categoria Tipo / Kategori /
Soort / Categoria / kategori / Typ **Vibrationsplatte**
- III **Typ /** Type / Type / Tipo / Codice / Type / Type / Tipo / Typ /
CR 6 , CR 6 CCD ,
CR 6 MSM
- IV **Nennleistung /** Nominal-performance / La puissance nominale / Prestazione nominale /
Potencia nominal / Nominaal vermogen / Nominel ydelse / Potência nominal / Nominell
effect / Moc **P = 7,4 kW**
- V **gemessener Schalleistungspegel /** measured sound power level / niveau de
puissance acoustique mesure / livello di potenza sonora rilevato / nivel de potencia
acústica medido / gemeten geluidsvermogensniveau / målt lydeffektniveau / Nivel de
potência sonora midido / uppmätt ljudeffektnivå / Mierzony poziom dźwięku **LWA = 106 dB (A)**
- VI **garantierter Schalleistungspegel /** guaranteed sound power level / niveau de
puissance acoustique garanti / livello di potenza sonora garantito / nivel de potencia
acustica garantizado / gewaarborgd geluidsvermogensniveau / garanteret lydeffektniveau /
Nivel sonoro garantido / garanterad ljudeffektniva / Natężenie hałas **LWA = 108 dB (A)**
- VII **beteiligte Zertifizierungsstelle /** notified body involved / de l'organisme notifié/
dell'organismo notificato che l'ha effettuata / dirección del organismo notificado que haya
intervenido / betrokken aangemelde instantie / pagældende bemyndigede organ /
organismo notificado envolvido / berörda anmälda organets namn / Jednostka
certyfikująca **RWTÜV**
Postfach 103161
D-45032 Essen
- VIII **Konformitäts-Bewertungsverfahren /** Conformity assessment procedure followed /
la procédure appliquée pour l'évaluation de la conformité et / procedura di valutazione
della conformità / procedimiento de evaluación de la conformidad / gevolgde
overeenstemmingsbeoordelingsprocedure / den fulgte
overensstemmelsesvurderingsprocedure / procedimento de avaliacao de conformidade
/Vilket förfarande för bedömning av överensstämmelse / Przebieg kontroli **interne Fertigungskontrolle**
nach Anhang VI
EG Richtlinie 2000/14/EG

ist in Übereinstimmung mit folgenden Richtlinien hergestellt worden / has been produced in accordance with following standards / est produit conforme aux dispositions des directives europeenes ci-apres / ha sido fabricado en conformidad con las siguientes normas / é stato fabbricato in conformità alle sequenti norme / er blevet fremstillet i overensstemmelse med følgende retningslinier / in overensstemming met de volgende voorschriften gefabriceerd is / é fabricado conforme as seguintes normas / har tillverkats i överensstämmelse med följande riktlinjer / Zgodność z obowiązującymi przepisami

98/37/EG Maschinenrichtlinie des europäischen Parlamentes und des Rates vom 22. Juni 1998
2000/14/EG EG-Richtlinie Geräuschemissionen vom 8. Mai 2000
2005/88/EG EG-Richtlinie vom 14. Dez. 2005 zur Änderung der Richtlinie 2000/14/EG
EN 500 Teil 1 Bewegliche Straßenbaumaschinen – Sicherheit
Gemeinsame Anforderungen
EN 500 Teil 4 Bewegliche Straßenbaumaschinen – Sicherheit
Besondere Anforderungen an Verdichtungsmaschinen

Bescheinigung bitte sorgfältig aufbewahren / File certificate carefully / Conserver certificat soigneusement / Conservar certificado cuidadosamente / Pregasi conservare accuratamente certificato / Beviset bedes opbevares omhyggeligt / Verklaring a.u.b. zorgvuldig beware / Conservar o certificado com cuidado / Beviset skall om sorgsfullt bevaras // Deklarację zgodności proszę zachować

Bad Laasphe – Rückershausen, den **02.01.2008**

W. Weber, Geschäftsführer

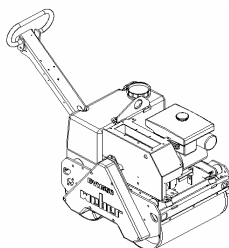

WEBER Maschinentechnik GmbH
Im Boden 5-8, 10 – D-57334 Bad Laasphe
Postfach 2153 – D-57329 Bad Laasphe
Telefon: 02754/398-0 – Fax 02754/398-101
E-mail: Verkauf@webermt.de
Internet: <http://www.webermt.de>

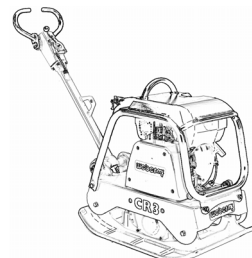

BITTE, NOTIEREN SIE SERIENNUMMER UND MOTORNUMMER IHRER MASCHINE:

PLEASE WRITE DOWN SERIALNUMBERS OF MACHINE AND ENGINE:

NOTEZ SVP LE NUMERO DE SERIE ET LE NUMERO DU MOTEUR DE VOTRE MACHINE:

SI PREGA DI ANNOTARE SEMPRE I NUMERI DI SERIE SIA DELLA VS. MACCHINA CHE DEL MOTORE:

MAQUINA: ROGAMOS ANOTEN EL NUMERO DE SERIE Y NUMERO DE MOTOR DE SU MAQUINA:

MASCHINE
MACHINE
MACCHINA
MAQUINA

#

MOTOR
ENGINE
MOTEUR
MOTORE

#

ZUR VERMEIDUNG VON FEHLLIEFERUNGEN UND VERZÖGERUNGEN SIND BEI DER BESTELLUNG VON ERSATZTEILEN FOLGENDE ANGABEN UNBEDINGT ERFORDERLICH:

- MASCHINENTYP
- SERIENNUMMER DER MASCHINE
- SERIENNUMMER DES MOTORS (BEI MOTORTEILEN)
- TEILENUMMER
- BESTELLMENGE

TO AVOID ERRORS IN DELIVERY PLEASE STATE THESE PARTICULARS WHEN ORDERING:

- TYPE OF MACHINE
- SERIAL NO. OF MACHINE
- SERIAL NO. OF ENGINE (ON ENGINE PARTS)
- PART-NO.
- QUANTITY REQUIRED

AFIN D'EVITER DES ERREURS DE COMMANDE ET DES RETARDS DE LIVRAISON IL EST NECESSAIRE D'INDIQUER LES CARACTERISTIQUES SUIVANTES:

- TYPE DE MACHINE
- LE NUMERO DE SERIE DE LA MACHINE
- LE NUMERO DE SERIE DU MOTEUR
- LE NUMERO D'IDENTITE DE LA PIECE
- LA QUANTITE SOUHAITEE

ONDE EVITARE DISGUIDI E RITARDI NELLE CONSEGNE DIE RICAMBI SI PREGA DI INDICARE SEMPRE:

- TIPO DELLA MACCHINA
- NUMERO DI SERIE DELLA MACCHINA
- NUMERO DI SERIE DEL MOTORE (SE SI RICHIEDONO PEZZI DEL MOTORE)
- NUMERO D'ORDINE DIE SINGOLI RICAMBI
- QUANTITA

A FI DE EVITAR ERRORES DE ENTREGA, ROGAMOS INDIQUEN LOS SIGUIENTES DATOS CUANDO PASE PEDIDOS DE RECAMBIO:

- MODELO DE MAQUINA
- NO. DE SERIE DE LA MAQUINA
- NO. DE SERIE DEL MOTOR (EN PIEZAS PARA MOTOR)
- REFERENCIA DEL RECAMBIO
- CANTIDAD PEDIDA

E 3275-0707

Position Ref.No. Repère Posizione Posicion	Menge Quantity Quantité Quantità Cantidad	Teile-Nr. Part-No. No. Référence Nr. d'Ordine No. Referenzia	Hinweis Hints Indications Indicazione Indicaciones	Position Ref. No. Repère Posizione Posicion	Menge Quantity Quantité Quantità Cantidad	Teile-Nr. Part-No. No. Référence Nr. d'Ordine No. Referenzia	Hinweis Hints Indications Indicazione Indicaciones
1	1	11000339					
2	1	25030002	DIN908-M14x1,5				
3	2	10017106					
4	6	25038029	DIN933-M20x70				
5	6	20029009	VSK 20				
6	2	10022636					
7	12	25038021	DIN933-M12x35				
8	12	20029026					
9	4	20004059					
11	8	20029030	SKM 16				
12	4	25031006	DIN934-M16				
13	4	25038023	DIN933-M16x25				
16	2	30047516					
17	12	25038007	DIN933-M8x20				
18	12	20029021	SKB 8				
19	10	21000308	DIN912-M16x120-10.9				
20	2	25045038	DIN912-M16x160-12.9				
21	12	20029029					
22	1	11000525					
23	1	11000369					
24	1	11000370					
25	2	20005011					
26	2	20029001	VSK 10				
27	2	25031004	DIN934-M10				
28	2	25044041	DIN912-M10x20				
29	2	20029001	VSK 10				
30	2	25031004	DIN934-M10				

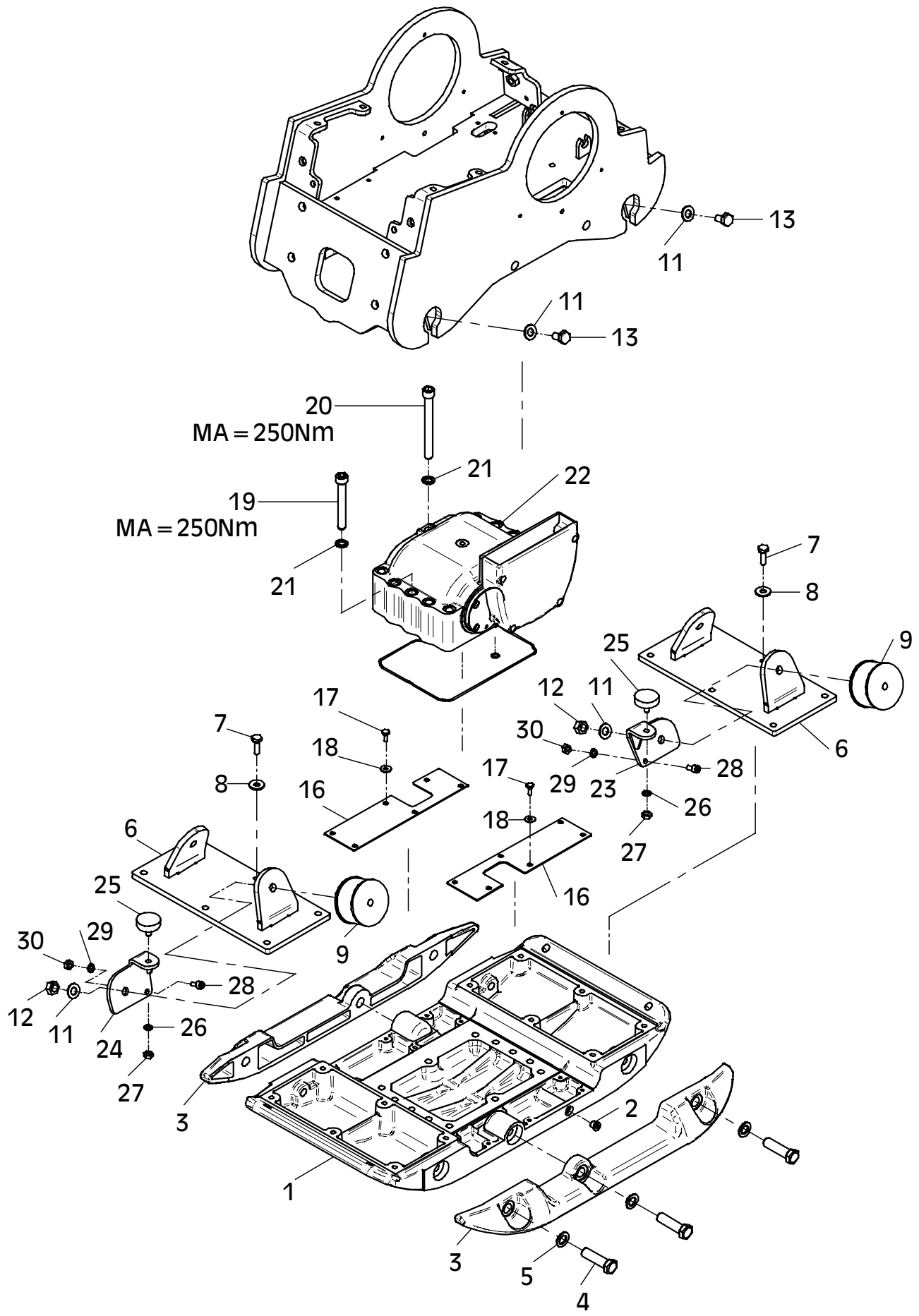

E 3276-0707

Position Ref.No. Repère Posizione Posicion	Menge Quantity Quantité Quantità Cantidad	Teile-Nr. Part-No. No. Référence Nr. d'Ordine No. Referenzia	Hinweis Hints Indications Indicazione Indicaciones	Position Ref. No. Repère Posizione Posicion	Menge Quantity Quantité Quantità Cantidad	Teile-Nr. Part-No. No. Référence Nr. d'Ordine No. Referenzia	Hinweis Hints Indications Indicazione Indicaciones
1	1	11000340		30	1	10016064	
2	1	25038042	DIN933-M12x16	31	1	20013269	
3	1	25008011	DIN7603-12x18x1,5	32	4	20029011	VSKZ 8
4	1	10016405		33	4	25044100	DIN912-M8x16
5	4	25044055	DIN912-M8x50	34	1	25008012	DIN7603-10x16x1
6	4	20029011	VSKZ 8	35	1	25030016	DIN910-M10x1
7	1	10016701		36	1	20020119	
8	1	10016071		37	2	25001144	
9	1	20029001	VSK 10	38	1	10016407	
10	1	10007370		39	2	25001135	
11	1	10016061		40	1	10016409	
12	4	20029011	VSKZ 8	41	1	25015046	
13	4	25044100	DIN912-M8x16	42	1	10017132	
14	1	20013269		43	2	25025157	
15	1	25017047		44	2	25045044	DIN912-M12x25-10.9
16	2	25001144		45	1	10016446	
17	1	10016407		46	1	10016414	
18	1	10016406		47	1	10016410	
19	1	25015046		48	1	25027004	DIN914-M8x16
20	1	10017131		49	1	10017369	
21	2	25025157		50	1	25035025	DIN472-I24x1,2
22	2	25045045	DIN912-M12x35-10.9	51	2	25001705	
23	0	20025528	DIN988-PS-56x72x0,1	52	1	25034032	DIN471-A9x1
24	0	20025029	DIN988-PS-56x72x0,2	53	1	10017370	
25	0	20025378	DIN988-PS-56x72x0,5	54	1	20013270	
26	2	20013269		55	1	21000306	
27	2	10016060		56	1	21000307	
28	8	20029011	VSKZ 8	57	2	10017368	
29	8	25044100	DIN912-M8x16	58	2	10017368	

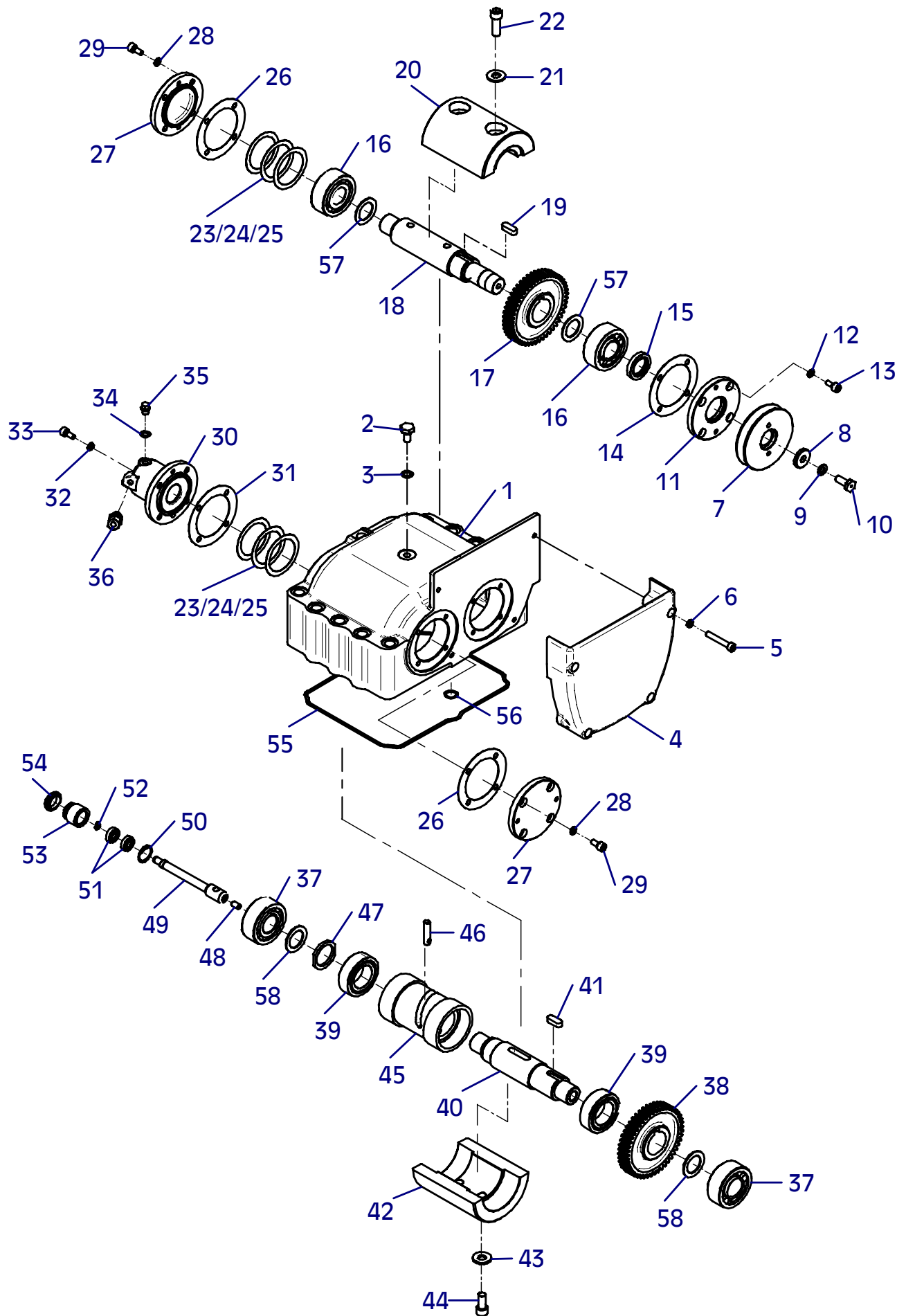

E 3276-0707

E 3127-0707

Position Ref.No. Repère Posizione Posicion	Menge Quantity Quantité Quantita Cantidad	Teile-Nr. Part-No. No. Référence Nr. d'Ordine No. Referenzia	Hinweis Hints Indications Indicazione Indicaciones	Position Ref. No. Repère Posizione Posicion	Menge Quantity Quantité Quantita Cantidad	Teile-Nr. Part-No. No. Référence Nr. d'Ordine No. Referenzia	Hinweis Hints Indications Indicazione Indicaciones
1	1	10022635		31	2	25031012	DIN985-M6
2	2	30047521		32	1	11000534	
3	6	25038007	DIN933-M8x20	33	4	25044045	DIN912-M16x40-10.9
4	6	20029031	SKM 8	34	4	20029027	
5	1	10022550		35	1	20026481	
6	2	25044005	DIN912-M8x20	36	2	25025191	DIN80705-M20x1,5
7	2	20029011	VSKZ 8	37	2	20025019	
8	1	25009021		38	1	10017337	
9	1	20025704		39	2	21000031	
10	1	10017127		40	2	11000148	
11	4	25038014	DIN933-M10x25	41	2	25040022	DIN931-M16x70
12	4	20029022	SKB 10	42	2	25031017	DIN985-M16
13	2	10017130		43	1	10017188	
14	4	25044039	DIN912-M16x40	44	1	20005001	
15	4	20029027		45	1	25031012	DIN985-M6
16	1	11000429		46	1	10015839	
17	6	25038014	DIN933-M10x25	47	1	25044037	DIN912-M10x55
18	6	20029022	SKB 10	48	1	25048003	DIN125-A10,5
19	1	20026544		49	1	20029001	VSK 10
20	1	20026545		50	1	25031004	DIN934-M10
21	1	25046015	DIN7984-M8x16				
22	1	20022002	Tensilock M8				
23	1	11000484					
24	4	25047020	DIN7991-M6x16				
25	4	20029007	VSK 6				
26	4	25031002	DIN934-M6				
27	1	11000015					
28	2	25033030	ISO7380-M6x20-10.9				
29	2	25049033	DIN9021-6,4/18x1,6				
30	2	25048001	DIN125-A6,4				

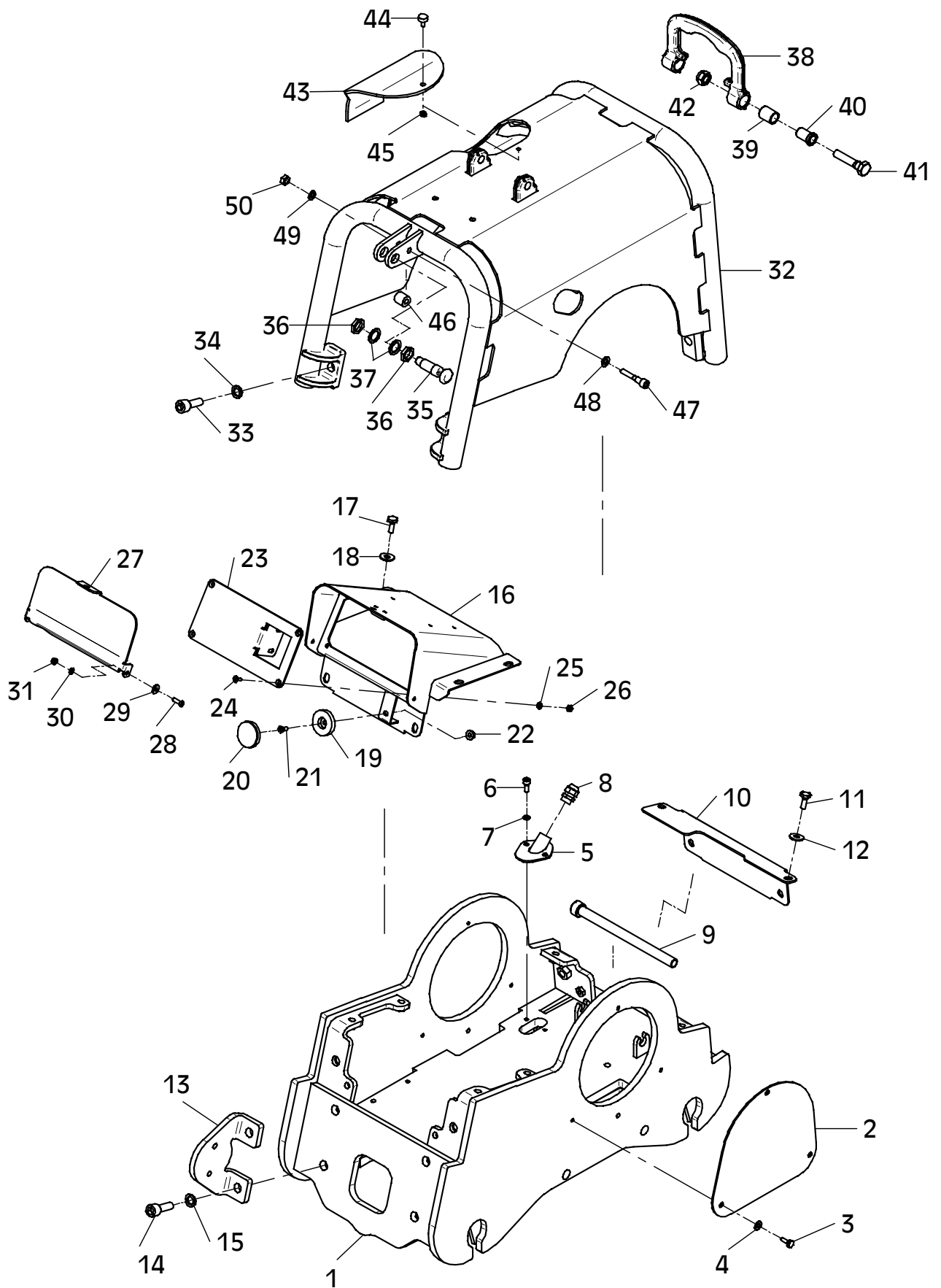

E 3214-0707

Position Ref.No. Repère Posizione Posicion	Menge Quantity Quantité Cantidad	Teile-Nr. Part-No. No. Référence Nr. d'Ordine No. Referenzia	Hinweis Hints Indications Indicazione Indicaciones	Position Ref. No. Repère Posizione Posicion	Menge Quantity Quantité Cantidad	Teile-Nr. Part-No. No. Référence Nr. d'Ordine No. Referenzia	Hinweis Hints Indications Indicazione Indicaciones
1	1	10022635		31	2	25031012	DIN985-M6
2	2	30047521		32	1	11000534	
3	6	25038007	DIN933-M8x20	33	4	25044045	DIN912-M16x40-10.9
4	6	20029031	SKM 8	34	4	20029027	
5	1	10022550		35	1	20026481	
6	2	25044005	DIN912-M8x20	36	2	25025191	DIN80705-M20x1,5
7	2	20029011	VSKZ 8	37	2	20025019	
8	1	25009021		38	1	10017337	
9	1	20025704		39	2	21000031	
10	1	10017127		40	2	11000148	
11	4	25038014	DIN933-M10x25	41	2	25040022	DIN931-M16x70
12	4	20029022	SKB 10	42	2	25031017	DIN985-M16
13	2	10017130		43	1	10017188	
14	4	25044039	DIN912-M16x40	44	1	20005001	
15	4	20029027		45	1	25031012	DIN985-M6
16	1	11000429		46	1	10015839	
17	6	25038014	DIN933-M10x25	47	1	25044037	DIN912-M10x55
18	6	20029022	SKB 10	48	1	25048003	DIN125-A10,5
19	1	20026544		49	1	20029001	VSK 10
20	1	20026545		50	1	25031004	DIN934-M10
21	1	25046015	DIN7984-M8x16	51	1	25038009	DIN933-M8x30
22	1	20022002	Tensilock M8	52	1	25048002	DIN125-A8,4
23	1	11000436		53	1	20007004	
24	4	25047020	DIN7991-M6x16	54	1	25031003	DIN934-M8
25	4	20029007	VSK 6				
26	4	25031002	DIN934-M6				
27	1	11000015					
28	2	25033030	ISO7380-M6x20-10.9				
29	2	25049033	DIN9021-6,4/18x1,6				
30	2	25048001	DIN125-A6,4				

Lombardini CCD

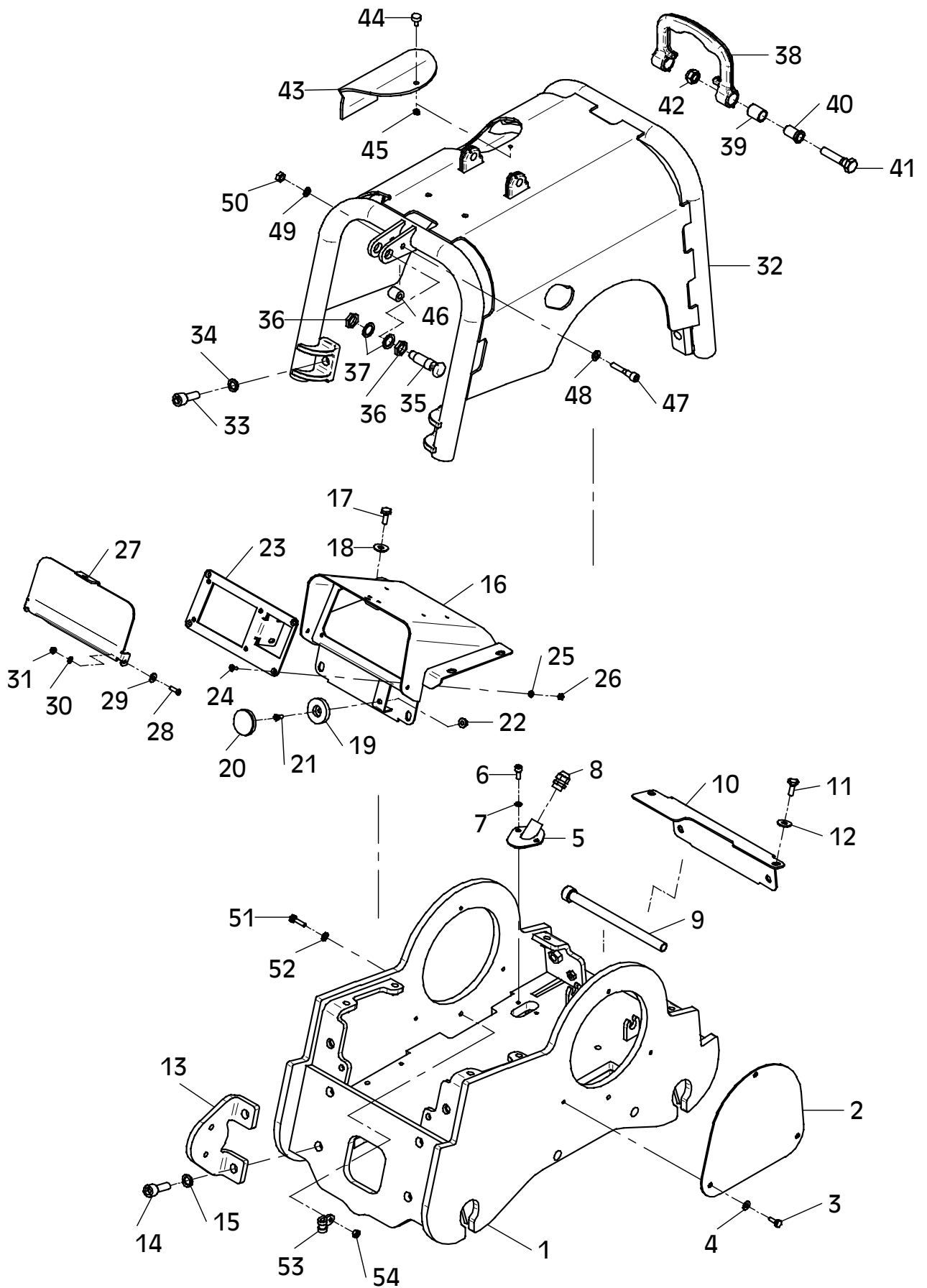

E 3214-0707

E 3279-0707

Position Ref.No. Repère Posizione Posicion	Menge Quantity Quantité Quantita Cantidad	Teile-Nr. Part-No. No. Référence Nr. d'Ordine No. Referenzia	Hinweis Hints Indications Indicazione Indicaciones	Position Ref. No. Repère Posizione Posicion	Menge Quantity Quantité Quantita Cantidad	Teile-Nr. Part-No. No. Référence Nr. d'Ordine No. Referenzia	Hinweis Hints Indications Indicazione Indicaciones
1	1	10022635		31	2	25031012	DIN985-M6
2	2	30047521		32	1	11000534	
3	6	25038007	DIN933-M8x20	33	4	25044045	DIN912-M16x40-10.9
4	6	20029031	SKM 8	34	4	20029027	
5	1	10022550		35	1	20026481	
6	2	25044005	DIN912-M8x20	36	2	25025191	DIN80705-M20x1,5
7	2	20029011	VSKZ 8	37	2	20025019	
8	1	25009021		38	1	10017337	
9	1	20025704		39	2	21000031	
10	1	10017127		40	2	11000148	
11	4	25038014	DIN933-M10x25	41	2	25040022	DIN931-M16x70
12	4	20029022	SKB 10	42	2	25031017	DIN985-M16
13	2	10017130		43	1	10017188	
14	4	25044039	DIN912-M16x40	44	1	20005001	
15	4	20029027		45	1	25031012	DIN985-M6
16	1	11000429		46	1	10015839	
17	6	25038014	DIN933-M10x25	47	1	25044037	DIN912-M10x55
18	6	20029022	SKB 10	48	1	25048003	DIN125-A10,5
19	1	20026544		49	1	20029001	VSK 10
20	1	20026545		50	1	25031004	DIN934-M10
21	1	25046015	DIN7984-M8x16				
22	1	20022002	Tensilock M8				
23	1	25038009	DIN933-M8x30				
24	1	25048002	DIN125-A8,4				
25	1	20007004					
26	1	25031003	DIN934-M8				
27	1	11000015					
28	2	25033030	ISO7380-M6x20-10.9				
29	2	25049033	DIN9021-6,4/18x1,6				
30	2	25048001	DIN125-A6,4				

Lombardini MSM

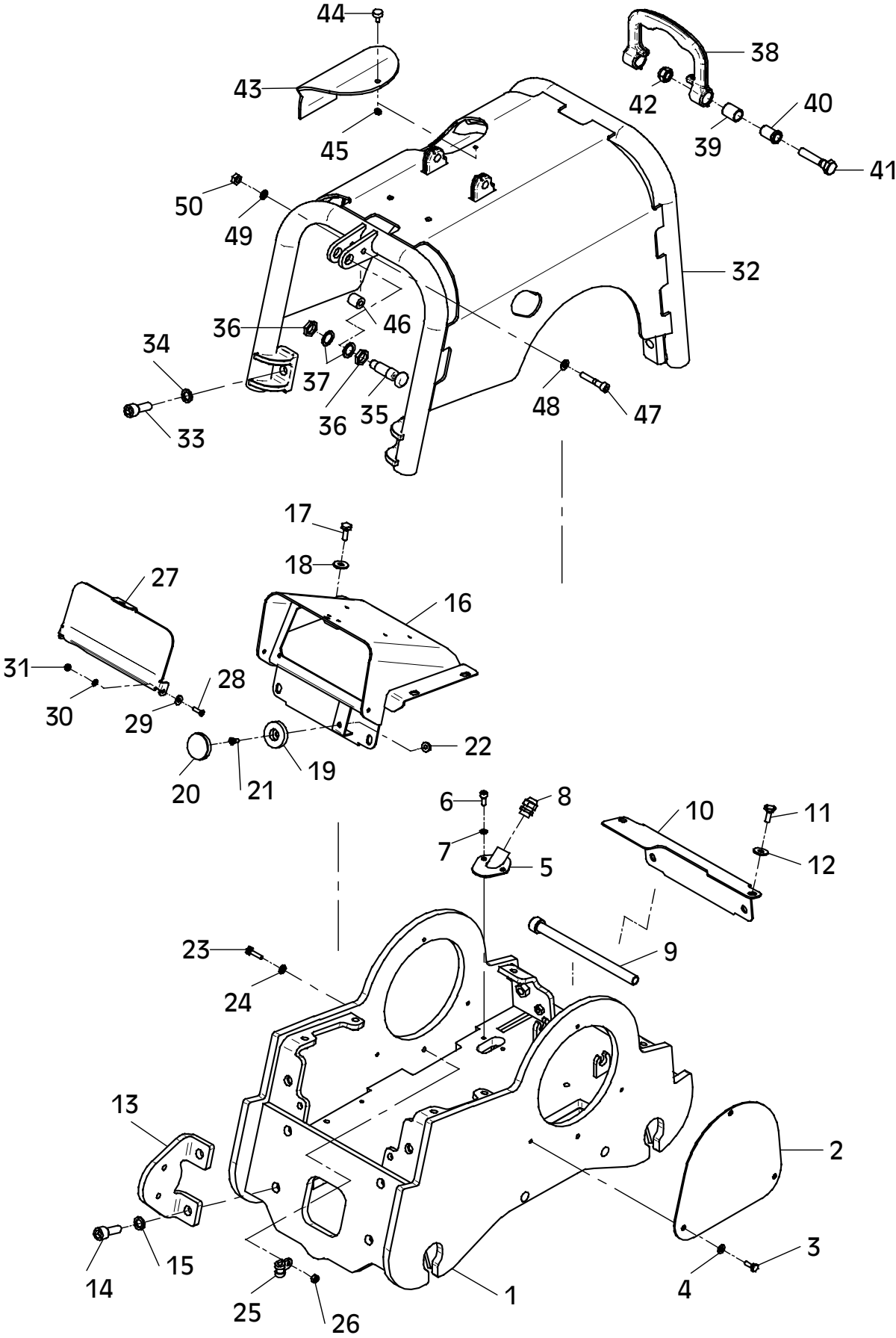

E 3232-0707

Position Ref.No. Repère Posizione Posicion	Menge Quantity Quantité Cantidad	Teile-Nr. Part-No. No. Référence Nr. d'Ordine No. Referenzia	Hinweis Hints Indications Indicazione Indicaciones	Position Ref. No. Repère Posizione Posicion	Menge Quantity Quantité Cantidad	Teile-Nr. Part-No. No. Référence Nr. d'Ordine No. Referenzia	Hinweis Hints Indications Indicazione Indicaciones
1	1	21000050		30	1	20007086	
1	1	21000053	EPA	31	1	10016539	
2	2	11000316		32	2	25044002	DIN912-M6x16
3	3	25040013	DIN931-M10x60	33	2	20029007	VSK 6
4	1	25040045	DIN931-M10x70	34	1	20007062	
5	4	25048003	DIN125-A10,5	35	1	25044065	DIN912-M6x25
6	4	25049008	DIN1440-12	36	1	25048001	DIN125-A6,4
7	4	20022003	Tensilock M10	37	1	25031002	DIN934-M6
8	2	25048003	DIN125-A10,5				
9	1	25031014	DIN985-M10				
10	1	20025702					
11	1	25008016	DIN7603-14x18x1,5				
12	1	11000214					
13	4	25042006	3/8"-16UNC				
14	4	20029033	SKM 10				
15	1	20026578	0,71 m				
16	2	20026578	0,06 m				
17	1	20002099					
18	1	25002179					
19	1	21000042	DIN912-M8x55-12.9				
20	1	20029011	VSKZ 8				
21	1	25049078	DIN6340-8,4				
22	1	11000179					
23	1	25038006	DIN933-M8x16				
24	1	20029031	SKM 8				
25	1	25038007	DIN933-M8x20				
26	1	20025122					
27	1	25049026	DIN7349-8,4				
28	1	20022002	Tensilock M8				
29	1	10022640					

Lombardini Lombardini CCD

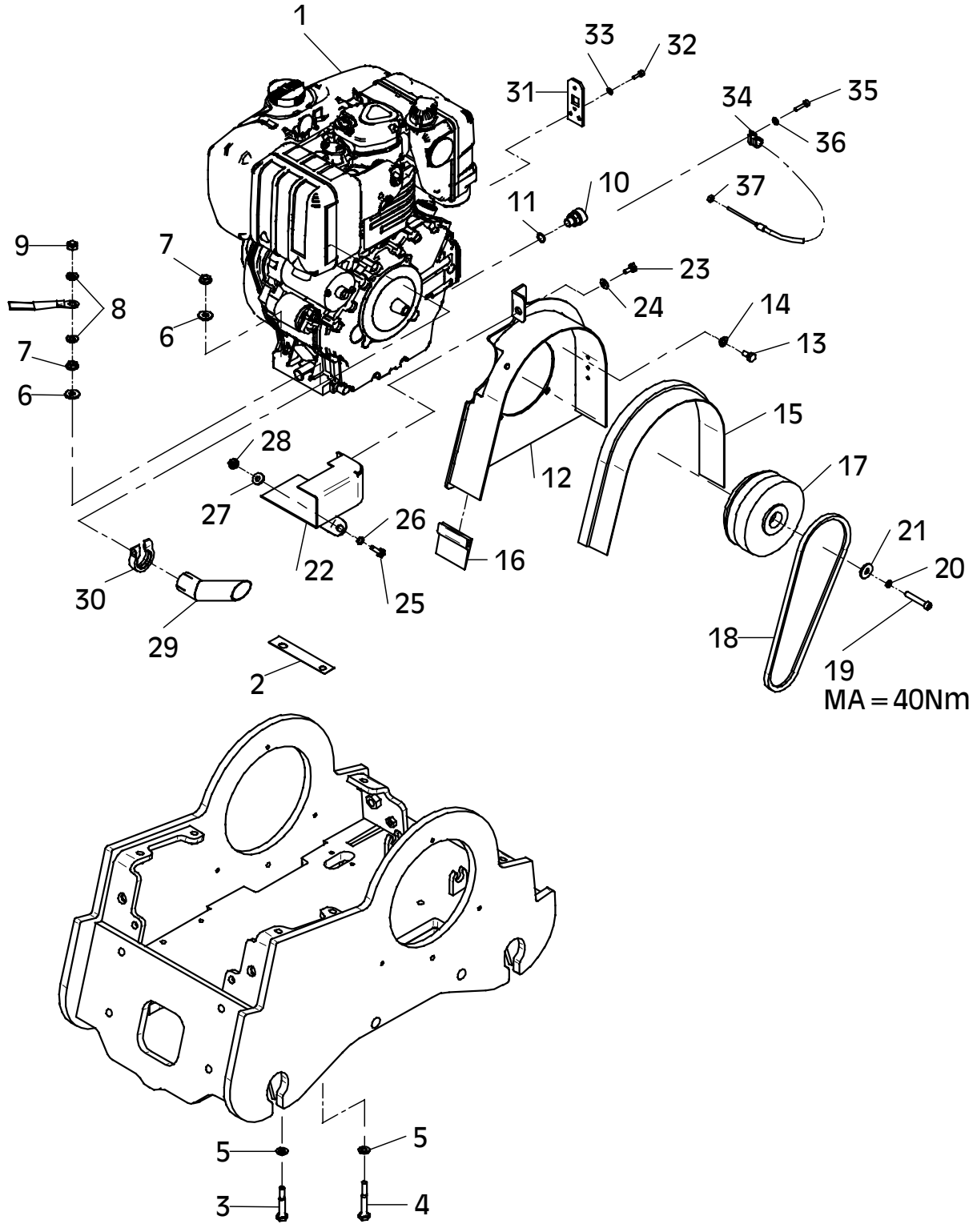

E 3292-0308

Position Ref.No. Repère Posizione Posicion	Menge Quantity Quantité Quantita Cantidad	Teile-Nr. Part-No. No. Référence Nr. d'Ordine No. Referenzia	Hinweis Hints Indications Indicazione Indicaciones	Position Ref. No. Repère Posizione Posicion	Menge Quantity Quantité Quantita Cantidad	Teile-Nr. Part-No. No. Référence Nr. d'Ordine No. Referenzia	Hinweis Hints Indications Indicazione Indicaciones
1	1	21000309		31	1	20007004	
2	2	11000316		32	1	30025021	0,48 m
3	3	25040013	DIN931-M10x60	33			
4	1	25040045	DIN931-M10x70	34	1	20007062	
5	4	25048003	DIN125-A10,5	35	1	25044065	DIN912-M6x25
6	4	25049008	DIN1440-12	36	1	25048001	DIN125-A6,4
7	4	20022003	Tensilock M10	37	1	25031002	DIN934-M6
8	2	25048003	DIN125-A10,5	38	1	11000600	
9	1	25031014	DIN985-M10	39	2	21000355	
10	1	20025702		40	4	20029007	VSK 6
11	1	25008016	DIN7603-14x18x1,5	41	2	25048001	DIN125-A6,4
12	1	11000214		42	2	25038002	DIN933-M6x16
13	4	25042006	3/8"-16UNC	43	1	21000417	
14	4	20029033	SKM 10	44	1	21000416	0,145 m
15	1	20026578	0,71 m				
16	2	20026578	0,06 m				
17	1	20002099					
18	1	25002179					
19	1	21000042	DIN912-M8x55-12.9				
20	1	20029011	VSKZ 8				
21	1	25049078	DIN6340-8,4				
22	1	11000179					
23	1	25038006	DIN933-M8x16				
24	1	20029031	SKM 8				
25	1	25038009	DIN933-M8x30				
26	1	20025122					
27	1	25049026	DIN7349-8,4				
28	1	20022002	Tensilock M8				
29	1	10022640					
30	1	20007086					

Lombardini MSM

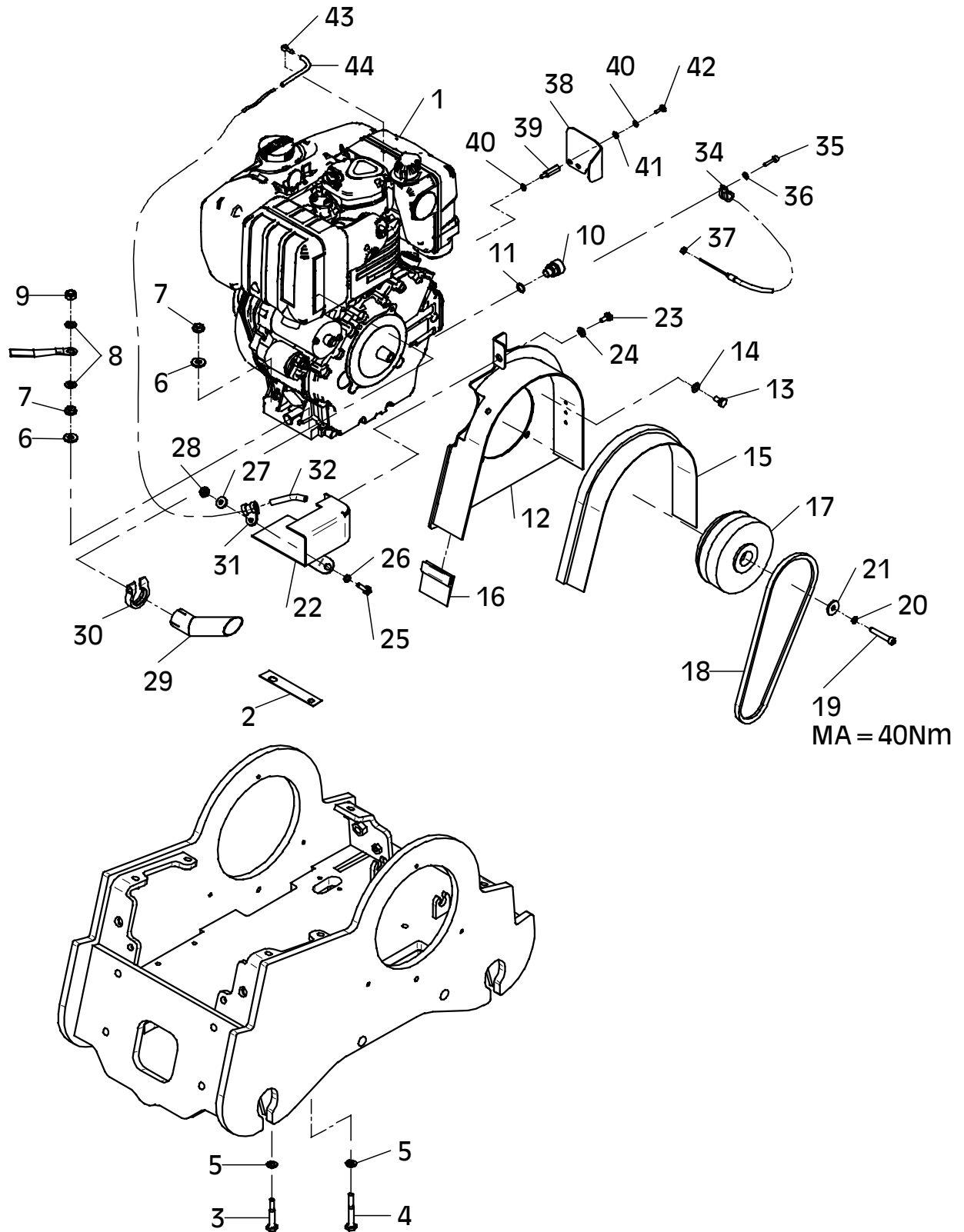

E 3128-0606

Position Ref.No. Repère Posizione Posicion	Menge Quantity Quantité Quantita Cantidad	Teile-Nr. Part-No. No. Référence Nr. d'Ordine No. Referenzia	Hinweis Hints Indications Indicazione Indicaciones	Position Ref. No. Repère Posizione Posicion	Menge Quantity Quantité Quantita Cantidad	Teile-Nr. Part-No. No. Référence Nr. d'Ordine No. Referenzia	Hinweis Hints Indications Indicazione Indicaciones
1	1	20002099					
2	2	20002548					
3	2	20002269					
4	2	21000151					
5	3	21000019					

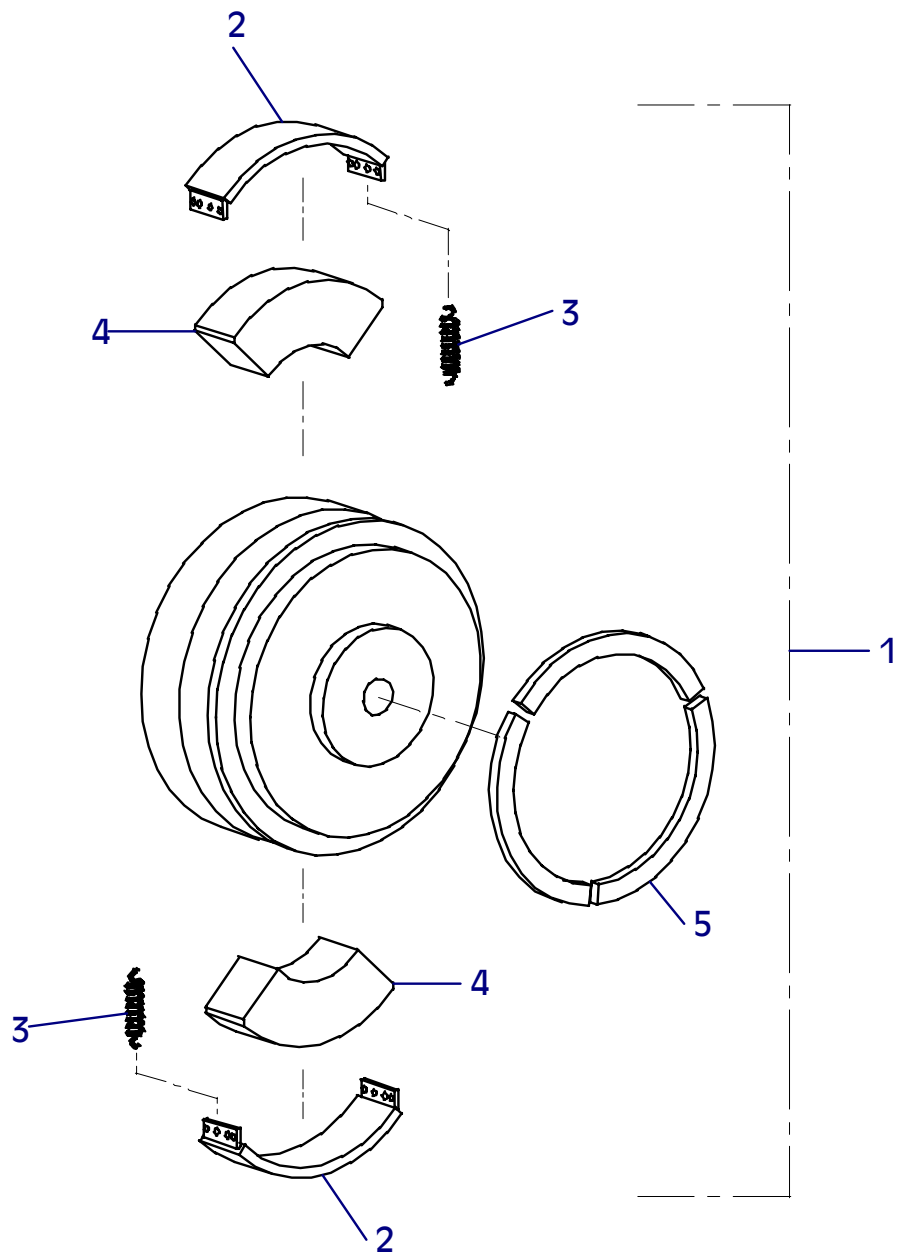

E 3277-0707

Position Ref.No. Repère Posizione Posicion	Menge Quantity Quantité Quantita Cantidad	Teile-Nr. Part-No. No. Référence Nr. d'Ordine No. Referenzia	Hinweis Hints Indications Indicazione Indicaciones	Position Ref. No. Repère Posizione Posicion	Menge Quantity Quantité Quantita Cantidad	Teile-Nr. Part-No. No. Référence Nr. d'Ordine No. Referenzia	Hinweis Hints Indications Indicazione Indicaciones
1	1	11000493					
2	4	21000325	DIN7981-C3,9x9,5				
4	1	11000487					
5	1	20007106					
6	1	21000272	CR 6				
6	1	21000273	CR 7				
7	1	11000490					
8	2	21000275	ISO7380-M10x30				
9	2	20025287					
10	1	11000491					
11	2	21000281					
12	4	20022002	Tensilock M8				
13	1	11000486					
14	1	11000488					
15	1	11000489					
16	1	21000268	DIN1481-4x40				
17	1	21000244					
18	1	11000556					
19	1	21000270					
20	1	20013279					
21	1	25031035	DIN986-M4				
22	1	21000274					

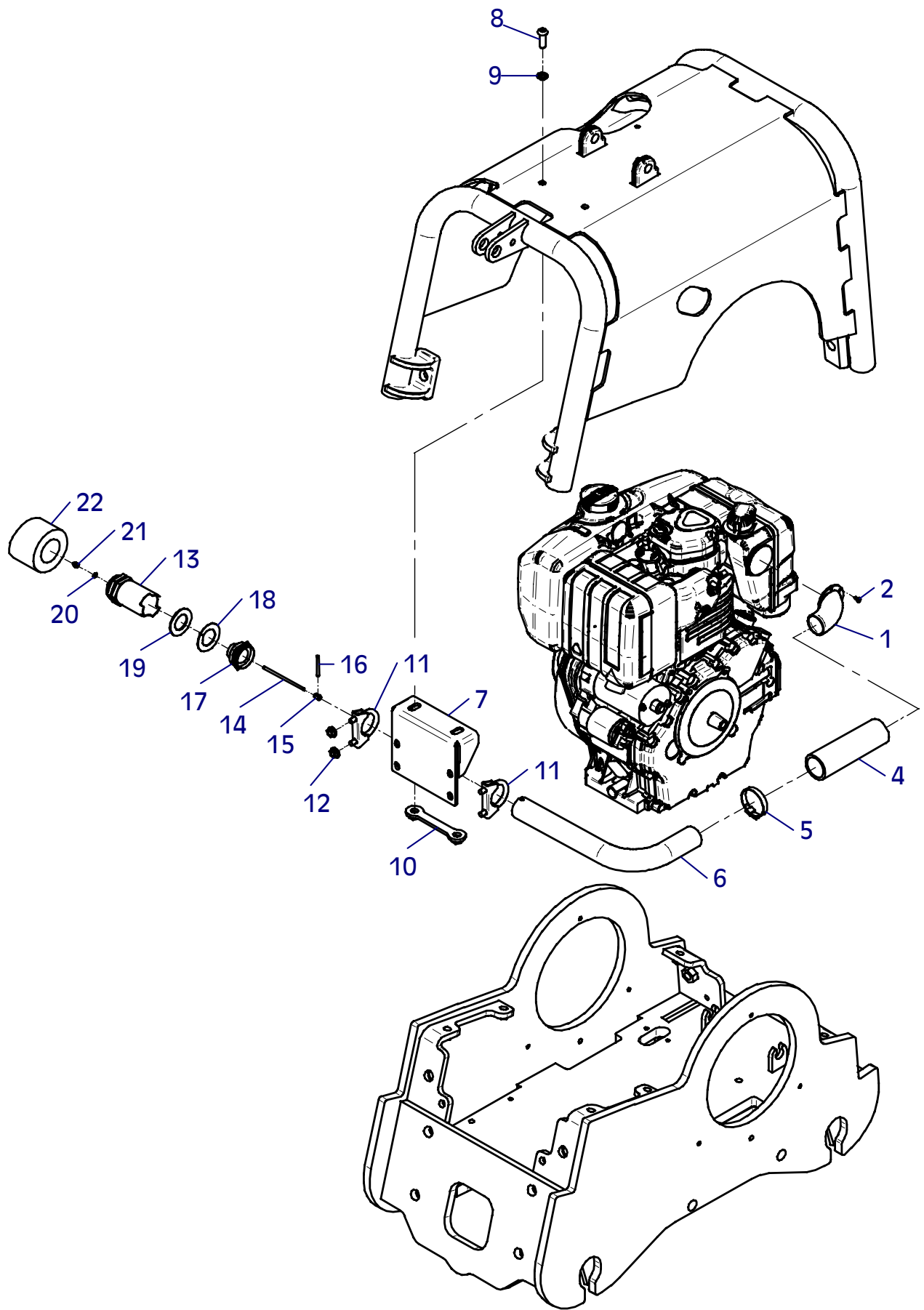

E 3277-0707

E 3130-0707

Position Ref.No. Repère Posizione Posicion	Menge Quantity Quantité Quantita Cantidad	Teile-Nr. Part-No. No. Référence Nr. d'Ordine No. Referenzia	Hinweis Hints Indications Indicazione Indicaciones	Position Ref. No. Repère Posizione Posicion	Menge Quantity Quantité Quantita Cantidad	Teile-Nr. Part-No. No. Référence Nr. d'Ordine No. Referenzia	Hinweis Hints Indications Indicazione Indicaciones
1	1	10003989					
2	1	20031502					
3	2	10015530					
4	1	20016289	0,40 m				
5	1	20025566					
6	1	30025028	0,19 m				
7	1	10015631					
8	1	25038007	DIN933-M8x20				
9	1	20029003	VSK 8				
10	1	25038011	DIN933-M8x40				
11	1	20029003	VSK 8				
12	1	20007004					
13	1	25031003	DIN934-M8				
14	2	25020028	DIN976-M8x200				
15	8	25031003	DIN934-M8				
16	2	20029003	VSK 8				
17	1	10001433					
18	1	10001467					
19	1	20031532					
20	2	25044076	DIN912-M5x16				
21	2	25048017	DIN125-A5,3				
22	2	25031023	DIN985-M5				
23	1	20031541					
24	1	10001469					
25	1	40080599					
26	2	25044005	DIN912-M8x20				
27	2	20029011	VSKZ 8				
28	2	25038002	DIN933-M6x16				
29	2	20029020	SKB 6				
30	1	21000353					

Lombardini

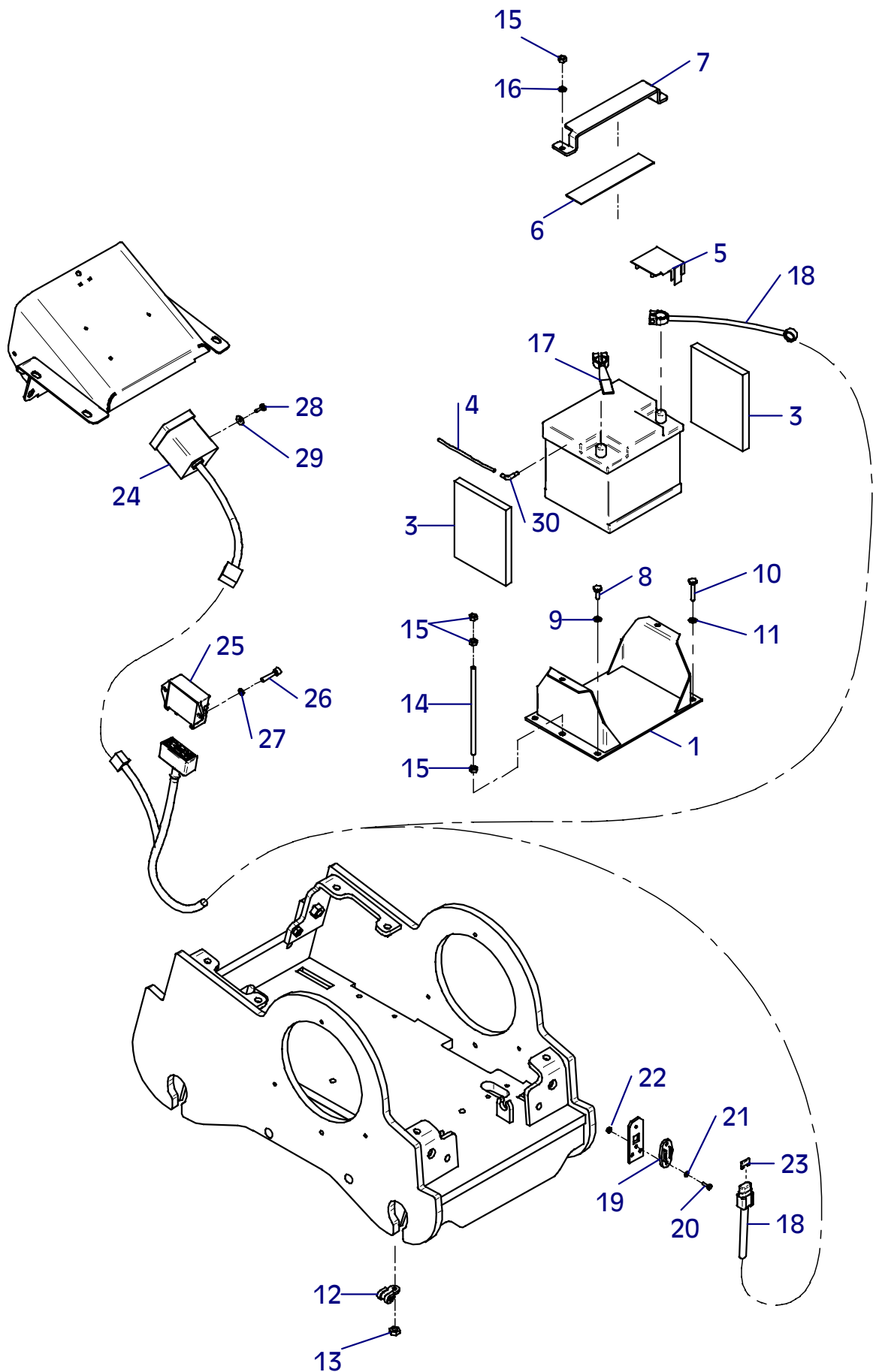

E 3130-0707

E 3215-0707

Position Ref.No. Repère Posizione Posicion	Menge Quantity Quantité Quantita Cantidad	Teile-Nr. Part-No. No. Référence Nr. d'Ordine No. Referenzia	Hinweis Hints Indications Indicazione Indicaciones	Position Ref. No. Repère Posizione Posicion	Menge Quantity Quantité Quantita Cantidad	Teile-Nr. Part-No. No. Référence Nr. d'Ordine No. Referenzia	Hinweis Hints Indications Indicazione Indicaciones
1	1	10003989		31	1	20026573	
2	1	20031502		32	4	25033029	ISO7380-M6x16-10.9
3	2	10015530		33	3	20022001	Tensilock M6
4	1	20016289	0,40 m	34	1	20029007	VSK 6
5	1	20025566		35	1	21000028	
6	1	30025028	0,19 m	36	1	20007007	
7	1	10015631		37	1	25038002	DIN933-M6x16
8	1	25038007	DIN933-M8x20	38	1	21000011	0,50 m
9	1	20029003	VSK 8	39	1	11000105	
10	1	25038011	DIN933-M8x40	40	2	25044005	DIN912-M8x20
11	1	20029003	VSK 8	41	2	20029011	VSKZ 8
12	1	20007004		42	1	20026574	
13	1	25031003	DIN934-M8	43	4	25044080	DIN912-M5x25
14	2	25020028	DIN976-M8x200	44	4	20029006	VSK 5
15	8	25031003	DIN934-M8	45	1	21000353	
16	2	20029003	VSK 8				
17	1	10001433					
18	1	11000150					
19	1	20031532					
20	2	25044076	DIN912-M5x16				
21	2	25048017	DIN125-A5,3				
22	2	25031023	DIN985-M5				
23	1	20031541					
24	1	20031579					
25	1	10001469					
26	2	25038002	DIN933-M6x16				
27	2	20029020	SKB 6				
28	1	40080599					
29	2	25044005	DIN912-M8x20				
30	2	20029011	VSKZ 8				

Lombardini CCD

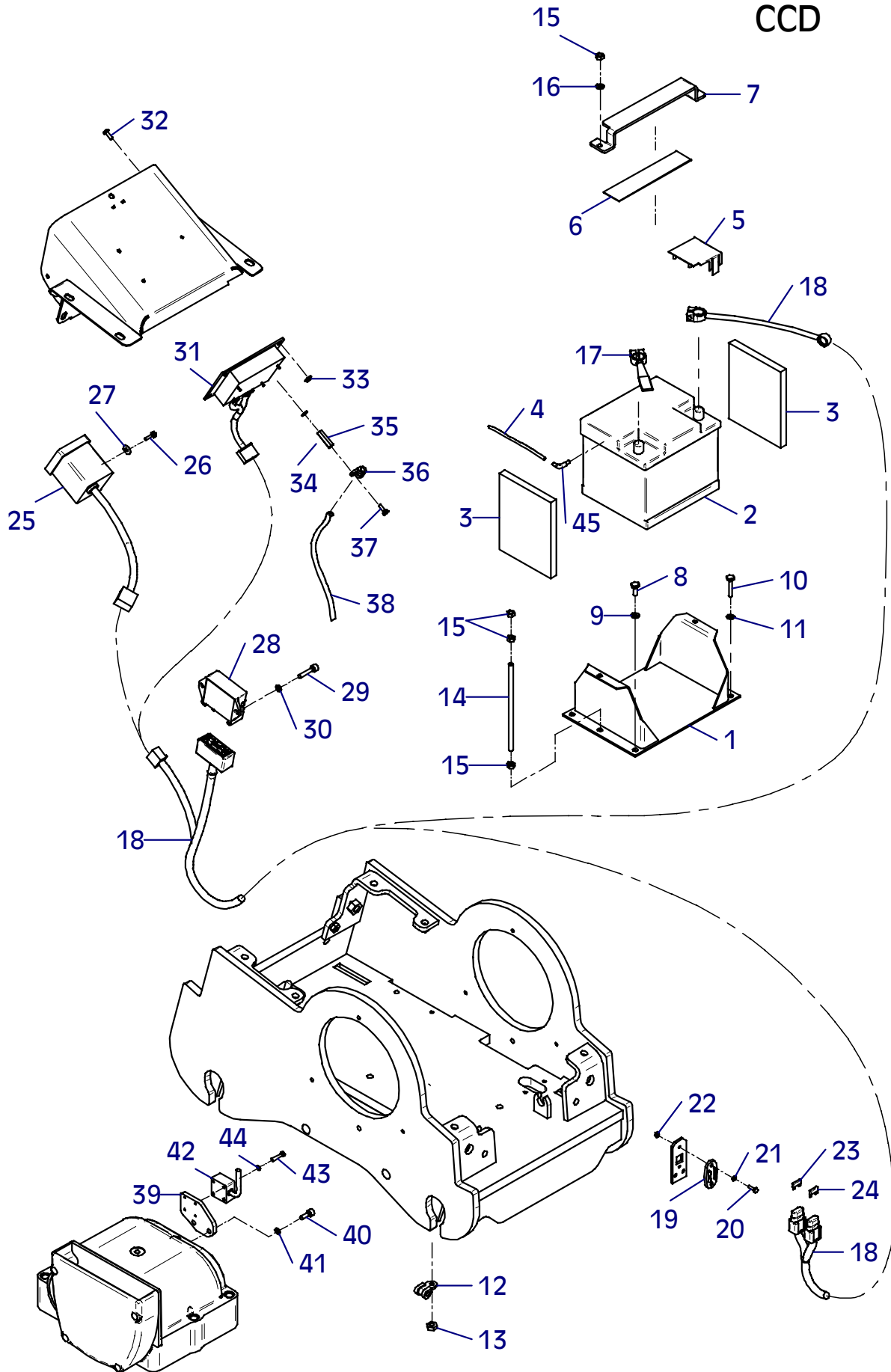

E 3215-0707

E 3278-0707

Position Ref.No. Repère Posizione Posicion	Menge Quantity Quantité Quantita Cantidad	Teile-Nr. Part-No. No. Référence Nr. d'Ordine No. Referenzia	Hinweis Hints Indications Indicazione Indicaciones	Position Ref. No. Repère Posizione Posicion	Menge Quantity Quantité Quantita Cantidad	Teile-Nr. Part-No. No. Référence Nr. d'Ordine No. Referenzia	Hinweis Hints Indications Indicazione Indicaciones
1	1	10003989		31	1	21000246	
2	1	20031502		32	4	25033029	ISO7380-M6x16-10.9
3	2	10015530		33	4	20022001	Tensilock M6
4	1	20016289	0,40 m	34	1	21000353	
5	1	20025566		35	1	11000105	
6	2	30025028	0,19 m	36	2	25044005	DIN912-M8x20
7	1	11000554		37	2	20029011	VSKZ 8
8	1	25038007	DIN933-M8x20	38	1	20026574	
9	1	20029003	VSK 8	39	4	25044080	DIN912-M5x25
10	1	25038011	DIN933-M8x40	40	4	20029006	VSK 5
11	1	20029003	VSK 8	41	3	21000249	
12	1	20007004		42	1	21000407	
13	1	25031003	DIN934-M8				
14	2	25020028	DIN976-M8x200				
15	8	25031003	DIN934-M8				
16	2	20029003	VSK 8				
17	1	10001433					
18	1	11000557					
19	1	20031532					
20	2	25047016	DIN7991-M5x16				
21	2	20022005	Tensilock M5				
22	2	20031541					
23	1	11000560					
24	1	31000038	0,56 m				
25	1	21000247					
26	3	25047016	DIN7991-M5x16				
27	3	20022005	Tensilock M5				
28	1	41000503					
29	2	25044005	DIN912-M8x20				
30	2	20029011	VSKZ 8				

Lombardini MSM

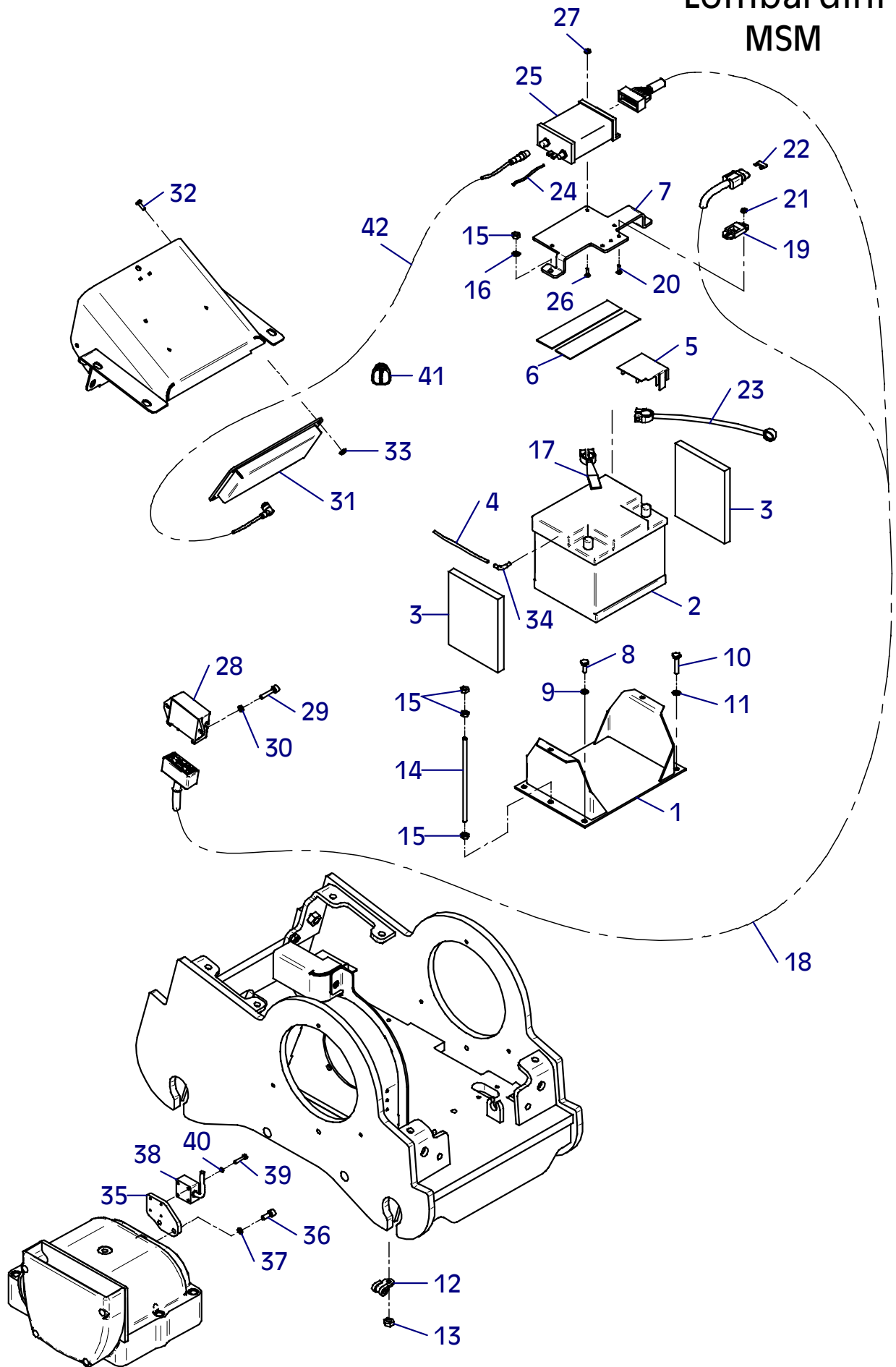

E 3278-0707

E 3216-0707

Position Ref.No. Repère Posizione Posicion	Menge Quantity Quantité Cantidad	Teile-Nr. Part-No. No. Référence Nr. d'Ordine No. Referenzia	Hinweis Hints Indications Indicazione Indicaciones	Position Ref. No. Repère Posizione Posicion	Menge Quantity Quantité Cantidad	Teile-Nr. Part-No. No. Référence Nr. d'Ordine No. Referenzia	Hinweis Hints Indications Indicazione Indicaciones
1	1	11000535		31	2	10017397	
2	2	10016331		32	2	25017048	
3	8	20029011	VSKZ 8	33	2	10017400	
4	8	25044046	DIN912-M8x55	34	2	25044035	DIN912-M12x25
5	2	10016442		35	2	20029013	VSKZ 12
6	2	20026493		36	2	20025593	
7	2	25040022	DIN931-M16x70	37	2	11000056	
8	2	20029002	VSK 16	38	4	25038008	DIN933-M8x25
9	4	20026492		39	4	20029003	VSK 8
10	2	20004016		40	1	11000038	
11	4	20029003	VSK 8	41	1	20008070	
12	4	25038008	DIN933-M8x25	42	1	10016022	
13	1	10016316		43	1	20013275	
14	1	20007202		44	1	10016102	
15	1	10022639		45	2	20013273	
16	1	25038079	DIN933-M20x35	46	1	20013274	
17	1	20029009	VSK 20	47	1	25035027	DIN472-I58x2
18	1	25048006	DIN125-A21	48	1	10016798	
19	1	10017133		49	1	20020119	
20	1	25025305		50	1	20016368	
21	1	25031020	DIN936-M16	51	4	25044006	DIN912-M8x25
22	1	20005019		52	4	20029011	VSKZ 8
23	1	25031004	DIN934-M10	53	1	20018134	
24	1	25009021		54	1	10016358	
25	1	10016797		55	2	25038070	DIN933-M6x30
26	1	25030003	DIN908-M24x1,5	56	2	20029007	VSK 6
27	1	25008008	DIN7603-24x32x2	57	1	20018021	
28	1	25030002	DIN908-M14x1,5	58	1	20006415	
29	1	10017394					
30	2	20013271					

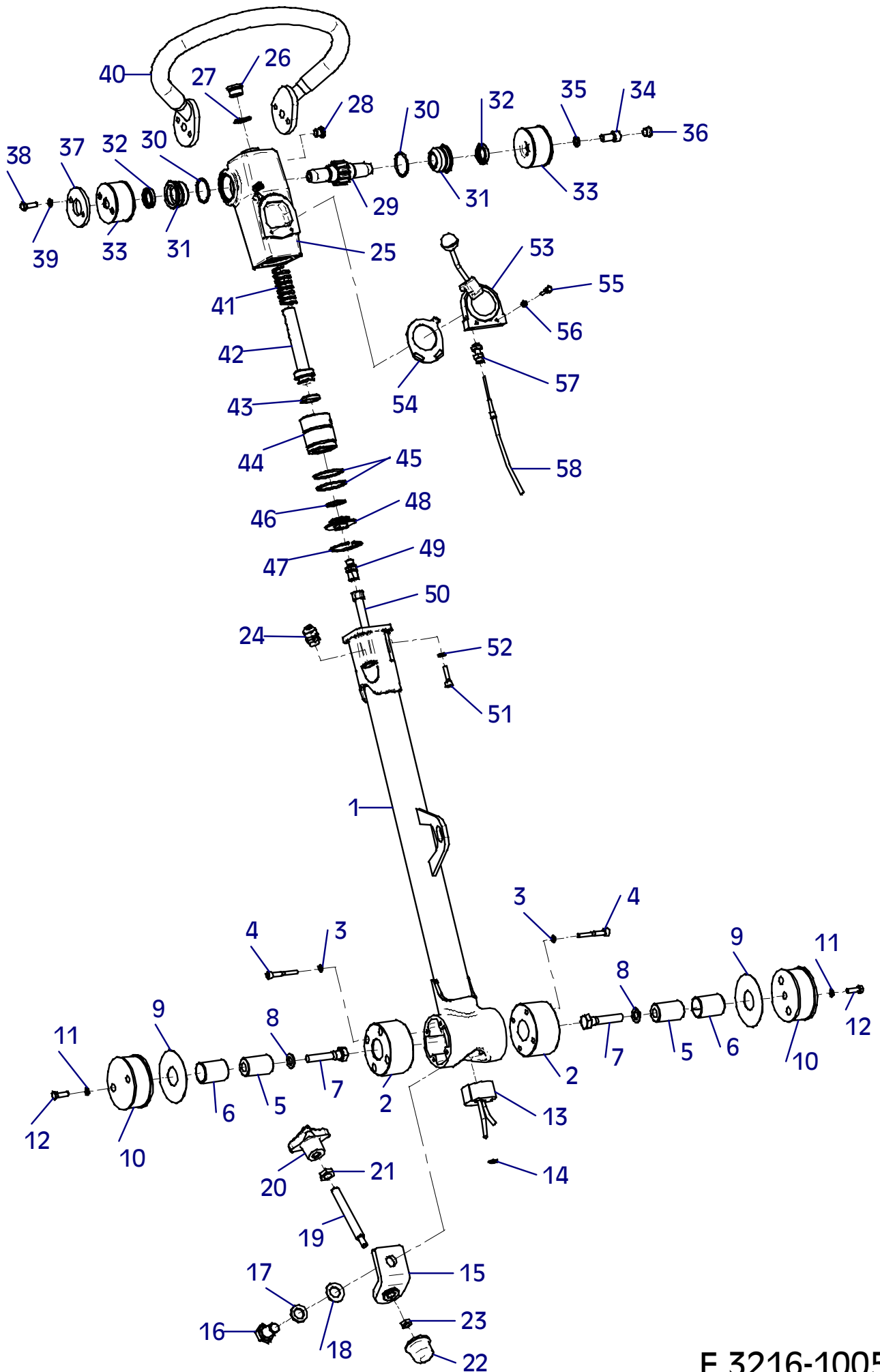

E 3216-1005

E 3131-0304

Position Ref.No. Repère Posizione Posicion	Menge Quantity Quantité Quantita Cantidad	Teile-Nr. Part-No. No. Référence Nr. d'Ordine No. Referenzia	Hinweis Hints Indications Indicazione Indicaciones	Position Ref. No. Repère Posizione Posicion	Menge Quantity Quantité Quantita Cantidad	Teile-Nr. Part-No. No. Référence Nr. d'Ordine No. Referenzia	Hinweis Hints Indications Indicazione Indicaciones
1	1	10017271					
2	2	10017292					
3	4	25040020	DIN931-M12x60				
4	4	20029004	VSK 12				
5	4	25031005	DIN934-M12				

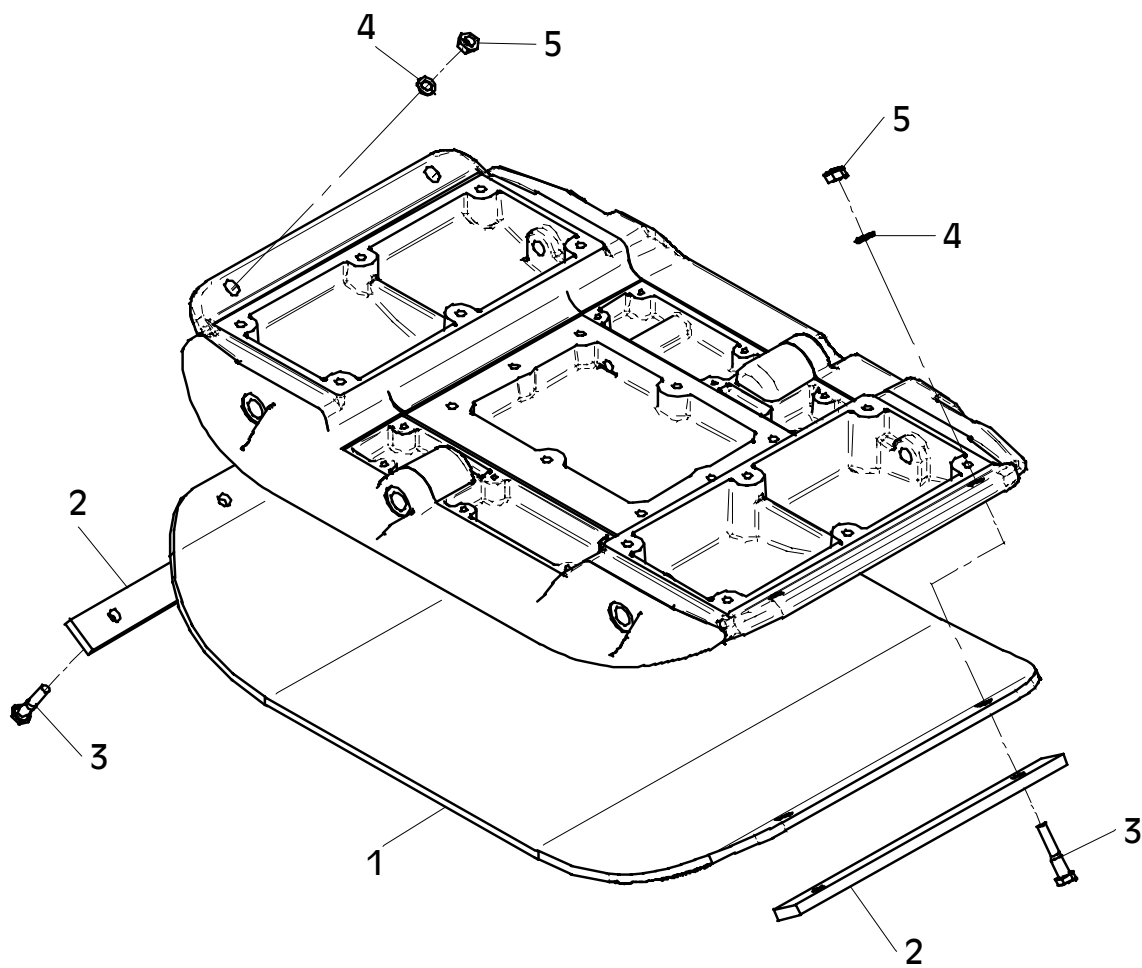

E 3131-0403

E 3217-1005

Position Ref.No. Repère Posizione Posicion	Menge Quantity Quantité Quantita Cantidad	Teile-Nr. Part-No. No. Référence Nr. d'Ordine No. Referenzia	Hinweis Hints Indications Indicazione Indicaciones	Position Ref. No. Repère Posizione Posicion	Menge Quantity Quantité Quantita Cantidad	Teile-Nr. Part-No. No. Référence Nr. d'Ordine No. Referenzia	Hinweis Hints Indications Indicazione Indicaciones
1	2	10017302					
2	1	10017326					
3	2	10017292					
4	4	25040020	DIN931-M12x60				
5	4	20029004	VSK 12				
6	4	25031005	DIN934-M12				

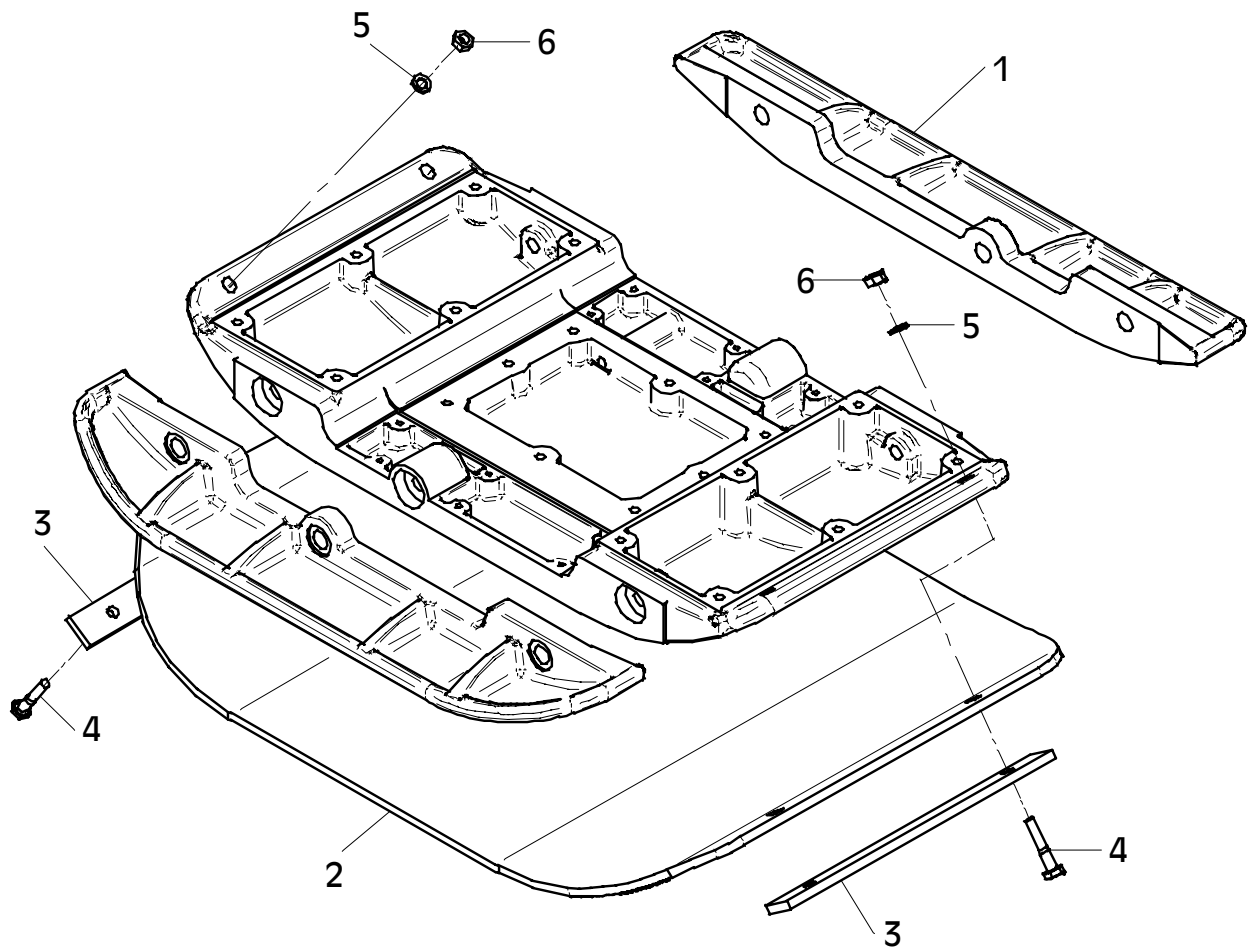

E 3217-1005

**Wenn Sie Fragen und Anregungen haben, oder sonstige Informationen benötigen,
wenden Sie sich bitte an eine der unten genannten Adressen:**

**For questions and further information refer to one of the
following addresses:**

<p>In Deutschland</p> <p>In Germany</p>	<p>WEBER Maschinenteknik GmbH Postfach 2153 57329 Bad Laasphe – Rückershausen</p> <p>Information / information: E-mail: info@webermt.de</p> <p>Ersatzteile / spare parts: E-mail: parts@webermt.de</p>	<p>Telefon / phone:</p> <p>Telefax / fax:</p> <p>Telefax / fax:</p>	<p>+49 (0) 2754 / 3980 Zentrale / switchboard</p> <p>+49 (0) 2754 / 398101 Zentrale / switchboard</p> <p>+49 (0) 2754 / 398102 Ersatzteile / spare parts direct dial</p>
<p>In Holland</p> <p>In Netherlands</p>	<p>WEBER Maschinenteknik B.V. Graafschap Hornelaan 159 6001 AC Weert</p> <p>E-mail: info@webermt.nl</p>	<p>Telefon / phone:</p> <p>Telefax / fax:</p>	<p>+31 (0) 495 / 530215</p> <p>+31 (0) 495 / 541839</p>
<p>In Frankreich</p> <p>In France</p>	<p>WEBER Technologie S.A.R.L. 26, rue d'Arsonval 69680 Chassieu</p> <p>E-mail: france@webermt.com</p>	<p>Telefon / phone:</p> <p>Telefax / fax:</p>	<p>+33 (0) 472 / 791020</p> <p>+33 (0) 472 / 791021</p>
<p>In Polen</p> <p>In Poland</p>	<p>WEBER Maschinenteknik SP.ZO.O. ul. Grodziska 7 05-830 Stara Wies / Nadarzyn</p> <p>E-mail: info@webermt.com.pl</p>	<p>Telefon / phone:</p> <p>Telefax / fax:</p>	<p>+48 (0) 22 / 7397080 +48 (0) 22 / 7397081</p> <p>+48 (0) 22 / 7397082</p>
<p>In USA, Kanada</p> <p>In USA, Canada</p>	<p>WEBER Machine (USA), Inc. 40 Johnson Ave 112 Bangor, ME 04401 USA</p> <p>E-mail: usa@webermt.com</p>	<p>Telefon / phone:</p> <p>Telefax / fax:</p>	<p>+1 (0) 207 / 9474990</p> <p>+1 (0) 207 / 9475452</p>
<p>In Südamerika</p> <p>In South America</p>	<p>WEBER Maschinenteknik do Brasil Ltda. Rua Sete de Setembro, 275 93332-470 Novo Hamburgo, RS Brasil</p> <p>E-mail: webermt@webermt.com.br</p>	<p>Telefon / phone:</p> <p>Telefax / fax:</p>	<p>+55 (0) 51 / 5873044</p> <p>+55 (0) 51 / 5872271</p>

<http://www.webermt.com>

