



ERSATZTEILLISTE

SPARE PARTS LIST

**LISTE DES PIECES
DE RECHANGE**

LISTINO RICAMBI

LISTA DE RECAMBIOS

**WYKAZ CZESCI
ZAMIENNYCH**



CR 7

011661-011662



Weber Maschinenteknik GmbH
Postfach 2153, 57329 Bad Laasphe-Rückershausen
Telefon 02754 / 398-0
Telefax (02754) 398-101 (Zentrale) u. 398-102 (Ersatzteile)

EG - KONFORMITÄTSERKLÄRUNG
EC DECLARATION OF CONFORMITY/ DECLARATION DE CONFORMITE CE
DICHIARAZIONE CE DI CONFORMITA / DECLARACION CE DE CONFORMIDAD
EG-VERKLARING VAN OVEREENSTEMMING / EF-OVERENSSTEMMELSESERKAERING
DECLARACAO CE DE CONFORMIDADE / EG-FÖRSÄKRAN OM ÖVERENSSTÄMMELSE
DEKLARACJA ZGODNOŚCI

**im Sinne der EG-Maschinenrichtlinie 98/37/EG
und der EG Richtlinie 2000/14/EG - Geräuschemissionen**

- I **Art / Category / Catégorie / Categoria Tipo / Kategori / Soort / Categoria / kategori / Typ**
- II **Hersteller (Typ) / Make (Type) / Marque (Type) / Marca (Tipo) / Marca (Codice) / Producent (Type) / Merk (Type) / Marca (Tipo) / Tillverkare (Typ) / Producent**
- III **Nennleistung / Nominal-performance / La puissance nominale / Prestazione nominale / Potencia nominal / Nominaal vermogen / Nominel ydelse / Potência nominal / Nominell effect / Moc**
- IV **gemessener Schalleistungspegel / measured sound power level / niveau de puissance acoustique mesure / livello di potenza sonora rilevato / nivel de potencia acústica medido / gemeten geluidsvermogensniveau / målt lydeffektniveau / Nivel de potência sonora midido / uppmätt ljudeffektnivå / Mierzony poziom dźwięku**
- V **garantierter Schalleistungspegel / guaranteed sound power level / niveau de puissance acoustique garanti / livello di potenza sonora garantito / nivel de potencia acústica garantizado / gwaarborgd geluidsvermogensniveau / garanteret lydeffektniveau / Nivel sonoro garantido / garanterad ljudeffektnivå / Natężenie hałasu**
- VI **beteiligte Zertifizierungsstelle / notified body involved / de l'organisme notifié/ dell'organismo notificato che l'ha effettuata / dirección del organismo notificado que haya intervenido / betrokken aangemelde instantie / pågældende bemyndigede organ / organismo notificado involucrado / berörda anmälda organets namn / Jednostka certyfikująca**
- VII **Konformitäts-Bewertungsverfahren / Conformity assessment procedure followed / la procédure appliquée pour l'évaluation de la conformité et / procedura di valutazione della conformità / procedimiento de evaluación de la conformidad / gevolgde overeenstemmingsbeoordelingsprocedure / den fulgte overensstemmelssesvurderingsprocedure / procedimento de avaliacao de conformidade / Vilket förfarande för bedömning av överensstämmelse / Przebieg kontroli**

**Vibrationsplatte
CR 7**



P = 8,1 kW

LWA = 108 dB (A)

LWA = 109 dB (A)

**RWTÜV
Postfach 103161
D-45032 Essen**

**interne Fertigungskontrolle
nach Anhang VI
EG Richtlinie 2000/14/EG**

ist in Übereinstimmung mit folgenden Richtlinien hergestellt worden / has been produced in accordance with following standards / est produit conforme aux dispositions des directives europeenes ci-apres / ha sido fabricado en conformidad con las siguientes normas / é stato fabbricato in conformità alle sequenti norme / er blevet fremstillet i overensstemmelse med følgende retningslinier / in overeenstemming met de volgende voorschriften gefabriceerd is / é fabricado conforme as seguintes normas / har tillverkats i överensstämmelse med följande riktlinjer / Zgodność z obowiązującymi przepisami

98/37/EG	Maschinenrichtlinie des europäischen Parlamentes und des Rates vom 22. Juni 1998
2000/14/EG	EG-Richtlinie Geräuschemissionen vom 8. Mai 2000
EN 500 Teil 1	Bewegliche Straßenbaumaschinen – Sicherheit
	Gemeinsame Anforderungen
EN 500 Teil 4	Bewegliche Straßenbaumaschinen – Sicherheit
	Besondere Anforderungen an Verdichtungsmaschinen

Bescheinigung bitte sorgfältig aufbewahren / File certificate carefully / Conserver certificat soigneusement / Conserver certificado cuidadosamente / Pregasi conservare accuratamente certificato / Beviset bedes opbevares omhyggeligt / Verklaring a.u.b. zorgvuldig bevar / Conserver o certificado com cuidado / Beviset skall om sorgsfullt bevaras // Deklarację zgodności proszę zachować

Bad Laasphe – Rückershausen, den **02.01.2004**

W. Weber, Geschäftsführer

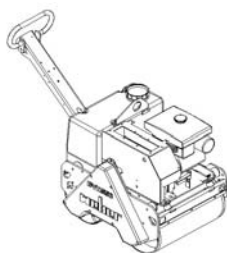

WEBER Maschinentechnik GmbH

Im Boden 5-8, 10 – D-57334 Bad Laasphe
Postfach 2153 – D-57329 Bad Laasphe
Telefon: 02754/398-0 – Fax 02754/398-101
E-mail: Verkauf@webermt.de
Internet: <http://www.webermt.de>



BITTE, NOTIEREN SIE SERIENNUMMER UND MOTORNUMMER IHRER MASCHINE:

PLEASE WRITE DOWN SERIALNUMBERS OF MACHINE AND ENGINE:

NOTEZ SVP LE NUMERO DE SERIE ET LE NUMERO DU MOTEUR DE VOTRE MACHINE:

SI PREGA DI ANNOTARE SEMPRE I NUMERI DI SERIE SIA DELLA VS. MACCHINA CHE DEL MOTORE:

MAQUINA: ROGAMOS ANOTEN EL NUMERO DE SERIE Y NUMERO DE MOTOR DE SU MAQUINA:

MASCHINE
MACHINE
MACCHINA
MAQUINA

#

MOTOR
ENGINE
MOTEUR
MOTORE

#

ZUR VERMEIDUNG VON FEHLLIEFERUNGEN UND VERZÖGERUNGEN SIND BEI DER BESTELLUNG VON ERSATZTEILEN FOLGENDE ANGABEN UNBEDINGT ERFORDERLICH:

- MASCHINENTYP
- SERIENNUMMER DER MASCHINE
- SERIENNUMMER DES MOTORS (BEI MOTORTEILEN)
- TEILENUMMER
- BESTELLMENGE

TO AVOID ERRORS IN DELIVERY PLEASE STATE THESE PARTICULARS WHEN ORDERING:

- TYPE OF MACHINE
- SERIAL NO. OF MACHINE
- SERIAL NO. OF ENGINE (ON ENGINE PARTS)
- PART-NO.
- QUANTITY REQUIRED

AFIN D'EVITER DES ERREURS DE COMMANDE ET DES RETARDS DE LIVRAISON IL EST NECESSAIRE D'INDIQUER LES CARACTERISTIQUES SUIVANTES:

- TYPE DE MACHINE
- LE NUMERO DE SERIE DE LA MACHINE
- LE NUMERO DE SERIE DU MOTEUR
- LE NUMERO D'IDENTITE DE LA PIECE
- LA QUANTITE SOUHAITEE

ONDE EVITARE DISGUIDI E RITARDI NELLE CONSEGNE DIE RICAMBI SI PREGA DI INDICARE SEMPRE:

- TIPO DELLA MACCHINA
- NUMERO DI SERIE DELLA MACCHINA
- NUMERO DI SERIE DEL MOTORE (SE SI RICHIEDONO PEZZI DEL MOTORE)
- NUMERO D'ORDINE DIE SINGOLI RICAMBI
- QUANTITA

A FI DE EVITAR ERRORES DE ENTREGA, ROGAMOS INDIQUEN LOS SIGUIENTES DATOS CUANDO PASE PEDIDOS DE RECAMBIO:

- MODELO DE MAQUINA
- NO. DE SERIE DE LA MAQUINA
- NO. DE SERIE DEL MOTOR (EN PIEZAS PARA MOTOR)
- REFERENCIA DEL RECAMBIO
- CANTIDAD PEDIDA

E 3089-0404

Position Ref.No. Repère Posizione Posicion	Menge Quantity Quantité Quantità Cantidad	Teile-Nr. Part-No. No. Référence Nr. d'Ordine No. Referenzia	Hinweis Hints Indications Indicazione Indicaciones	Position Ref. No. Repère Posizione Posicion	Menge Quantity Quantité Quantità Cantidad	Teile-Nr. Part-No. No. Référence Nr. d'Ordine No. Referenzia	Hinweis Hints Indications Indicazione Indicaciones
1	1	10016757					
2	1	25030002	DIN908-M14x1,5				
3	4	20026485					
4	2	10016758					
5	6	20029009	VSK 20				
6	6	25038032	DIN933-M20x40				
7	1	20013299					
8	1	30047368					
9	9	20029021	SKB 8				
10	9	25038008	DIN933-M8x25				
11	2	10016162					
12	2	10016163					
13	12	20025158					
14	12	25038022	DIN933-M12x40				
15	4	20004059					
16	8	25049019	DIN7349-17x40x6				
17	8	20029002	VSK 16				
18	4	25031006	DIN934-M16				
19	4	25038024	DIN933-M16x30				
20	4	10016367					
21	4	20025158					
22	4	10001423					
23	4	20005018					
24	1	10001447					
25	8	20029026					
26	6	25045033	DIN912-M12x140				
27	2	25045034	DIN912-M12x170				
28	4	30047495	Lombardini				

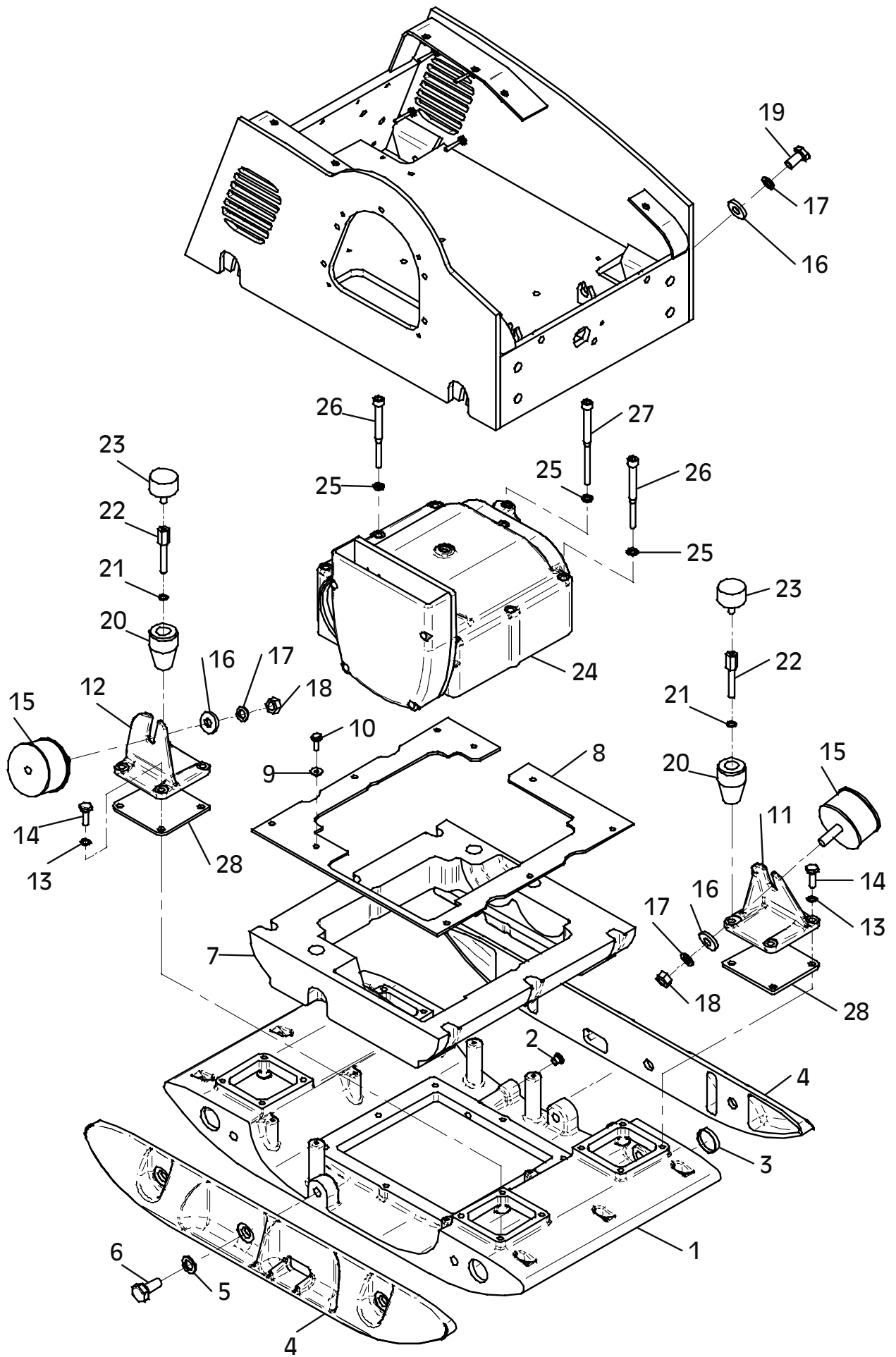

E 3089-0404

E 3090-0403

Position Ref.No. Repère Posizione Posicion	Menge Quantity Quantité Quantita Cantidad	Teile-Nr. Part-No. No. Référence Nr. d'Ordine No. Referenzia	Hinweis Hints Indications Indicazione Indicaciones	Position Ref. No. Repère Posizione Posicion	Menge Quantity Quantité Quantita Cantidad	Teile-Nr. Part-No. No. Référence Nr. d'Ordine No. Referenzia	Hinweis Hints Indications Indicazione Indicaciones
1	1	10016164		29	1	10017035	Honda
2	1	25038042	DIN933-M12x16	30	1	10016388	
3	1	25008011		31	1	10007370	
4	1	10016165		32	1	20029001	VSK 10
5	4	25044010	DIN912-M8x65	33	1	10016382	
6	4	20029011	VSKZ 8	34	2	25001701	
7	2	10016167		35	1	10016910	
8	8	25044005	DIN912-M8x20	36	2	25025157	
9	8	20029011	VSKZ 8	37	2	25045035	DIN912-M12x50
10	2	20013290		38	1	10016386	
11	1	10016166		39	2	25001702	
12	4	25044005	DIN912-M8x20	40	1	10016171	
13	4	20029011	VSKZ 8	41	1	10016383	
14	1	25017201		42	1	10016385	
15	1	20013290		43	1	25029015	
16	1	10016168		44	1	25028004	DIN915-M10x25
17	4	25044005	DIN912-M8x20	45	1	25035018	DIN472-I32
18	4	20029011	VSKZ 8	46	1	25001703	
19	1	25030016	DIN910-M10x1	47	1	25034025	DIN471-A15x1
20	1	25008012		48	1	10016387	
21	1	20013290		49	1	20013275	
22	1	10016379		50	1	25030001	DIN908-M10x1
23	2	25001701		51	1	20020562	
24	1	10016170		52	0	25026027	
25	1	25015076		53	0	25026028	
26	2	10016909		54	0	25026029	
27	2	25025157					
28	2	25045035	DIN912-M12x50				
29	1	10016911	Lombardini				

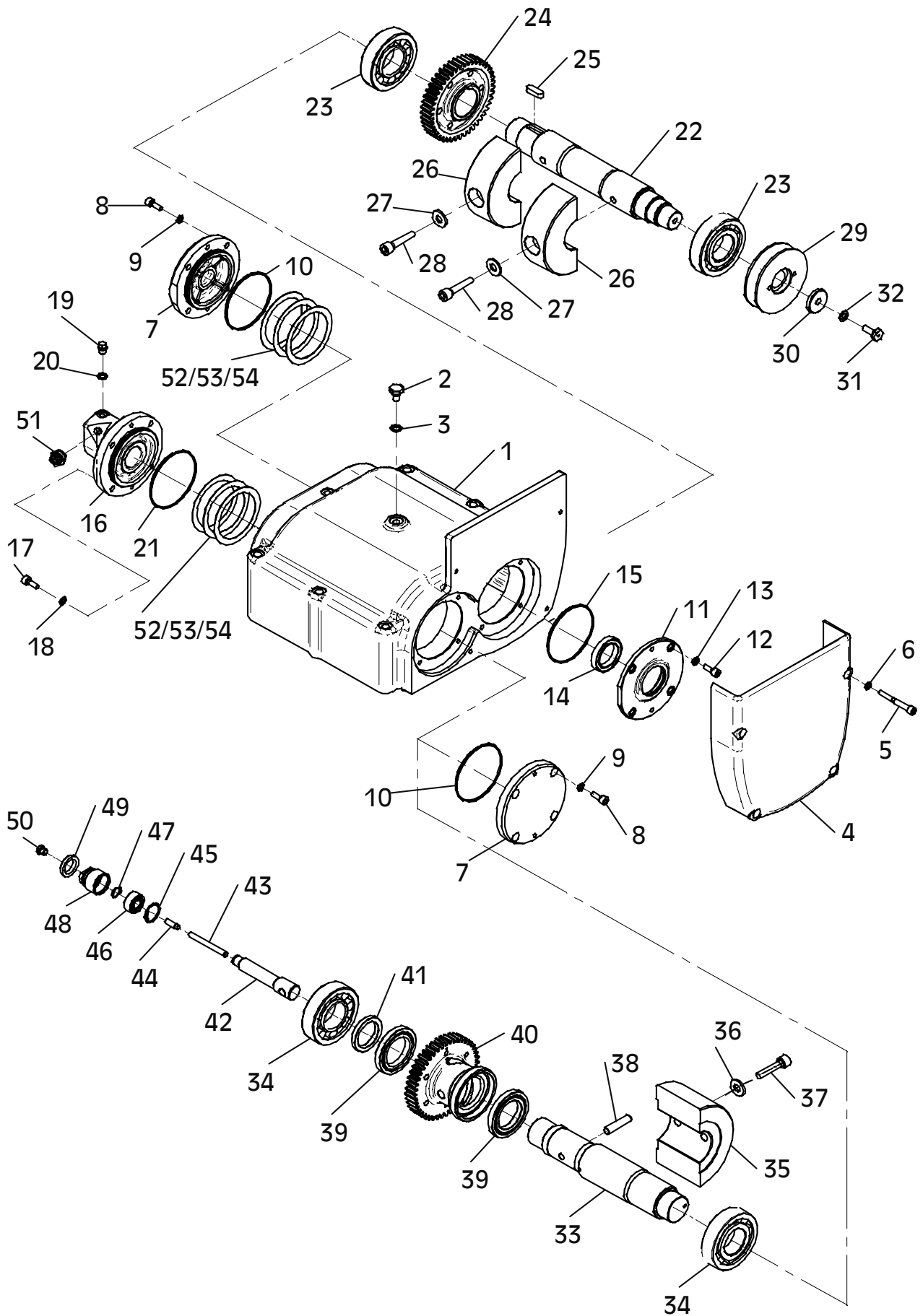

E 3090-0403

E 3091-0403

Position Ref.No. Repère Posizione Posicion	Menge Quantity Quantité Quantità Cantidad	Teile-Nr. Part-No. No. Référence Nr. d'Ordine No. Referenzia	Hinweis Hints Indications Indicazione Indicaciones	Position Ref. No. Repère Posizione Posicion	Menge Quantity Quantité Quantità Cantidad	Teile-Nr. Part-No. No. Référence Nr. d'Ordine No. Referenzia	Hinweis Hints Indications Indicazione Indicaciones
1	1	10022584		30	4	20026565	
2	1	10016839		31	1	10015839	
3	5	25049035	VSF 10	32	1	25044099	DIN912-M10x50
4	5	25038014	DIN933-M10x25	33	1	25048003	DIN125-A10,5
5	1	30047385		34	1	20029001	VSK 10
6	4	20029003	VSK 8	35	1	25031004	DIN934-M10
7	4	25038073	DIN933-M8x12	36	1	20026481	
8	1	10022602		37	2	25025191	DIN80705-M20x1,5
9	1	30047379		38	2	20025019	
10	8	10016855		39	1	10015839	
11	8	20029003	VSK 8	40	1	25049016	DIN440-R9
12	8	25031003	DIN934-M8	41	1	20007077	
13	1	20005006		42	1	25048002	DIN125-A8,4
14	1	20029004	VSK 12	43	1	25038007	DIN933-M8x20
15	1	25038022	DIN933-M12x40				
16	1	10022578					
17	8	25049035	VSF 10				
18	8	25038013	DIN933-M10x20				
19	1	10022577					
20	5	25044002	DIN912-M6x16				
21	5	20022001	Tensilock M6				
22	1	10016914					
23	2	10016929					
24	1	20007077					
25	1	25048002	DIN125-A8,4				
26	1	25040028	DIN931-M8x45				
27	1	10022579					
28	8	25044045	DIN912-M16x40				
29	8	20029029					

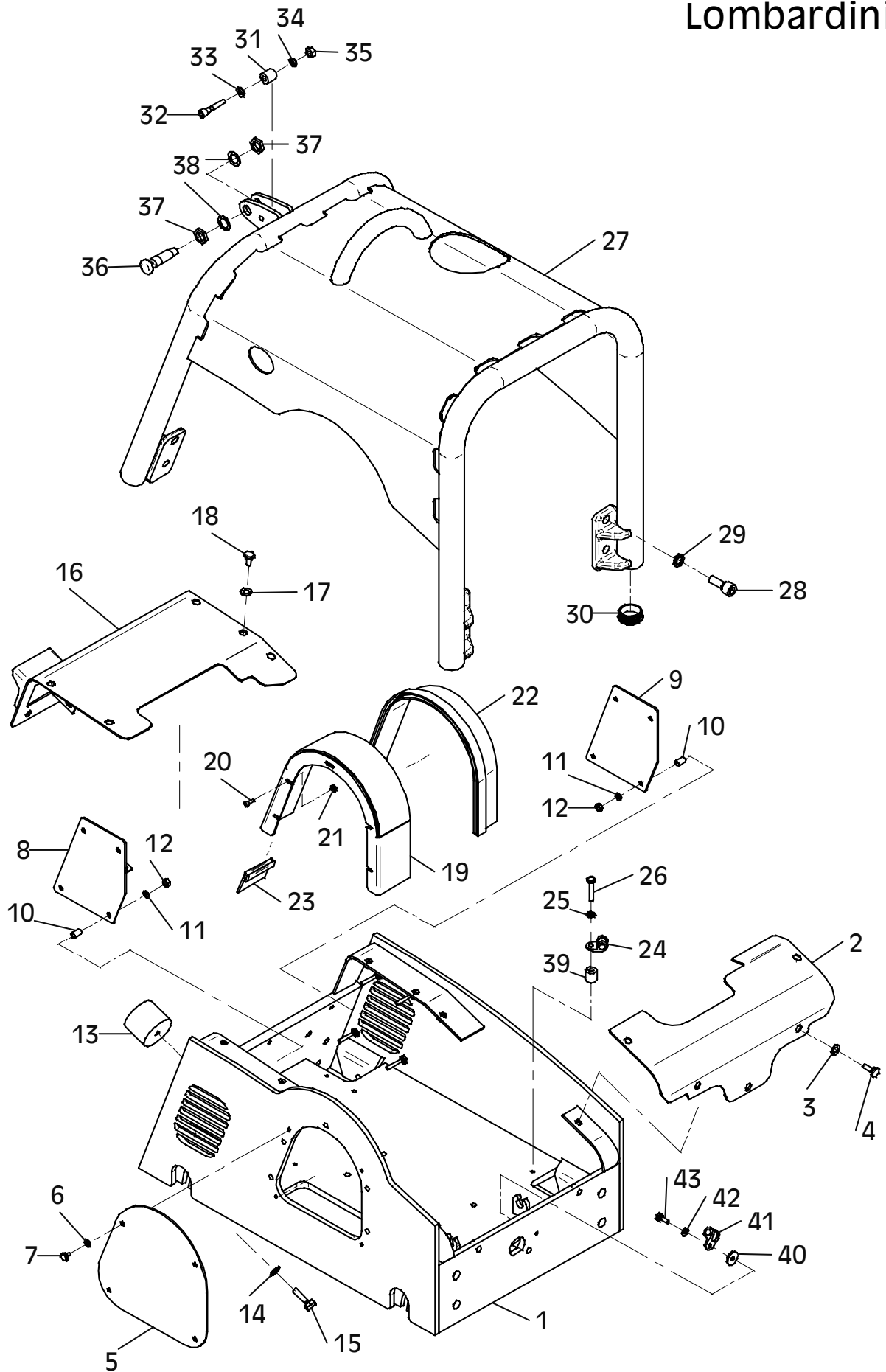

E 3092-0503

Position Ref.No. Repère Posizione Posicion	Menge Quantity Quantité Quantità Cantidad	Teile-Nr. Part-No. No. Référence Nr. d'Ordine No. Referenzia	Hinweis Hints Indications Indicazione Indicaciones	Position Ref. No. Repère Posizione Posicion	Menge Quantity Quantité Quantità Cantidad	Teile-Nr. Part-No. No. Référence Nr. d'Ordine No. Referenzia	Hinweis Hints Indications Indicazione Indicaciones
1	1	10022605		31	1	10022603	
2	1	10017014		32	8	25044045	DIN912-M16x40
3	7	25049035	VSF 10	33	8	20029029	
4	7	25038014	DIN933-M10x25	34	4	20026565	
5	1	30047430		35	1	10017038	
6	4	20029003	VSK 8	36	1	30047480	
7	4	25038073	DIN933-M8x12	37	3	25033030	ISO7380-M6x20
8	1	20005006		38	1	20026481	
9	1	20029004	VSK 12	39	2	25025191	DIN80705-M20x1,5
10	1	25038022	DIN933-M12x40	40	2	20025019	
11	1	10015839		41	1	10015839	
12	1	20007077		42	1	25044099	DIN912-M10x50
13	1	25048002	DIN125-A8,4	43	1	25048003	DIN125-A10,5
14	1	25040065	DIN931-M8x40	44	1	20029001	VSK 10
15	1	25049016	DIN440-R9	45	1	25031004	DIN934-M10
16	1	20007077		46	1	20007007	
17	1	25048002	DIN125-A8,4	47	1	25038002	DIN933-M6x16
18	1	25038008	DIN933-M8x25				
19	1	10022604					
20	1	10016914					
21	5	25044002	DIN912-M6x16				
22	5	20022001	Tensilock M6				
23	1	10017013					
24	7	25049035	VSF 10				
25	7	25038013	DIN933-M10x20				
26	1	10017037					
27	1	25009020					
28	1	40140041					
29	1	10001454					

Honda

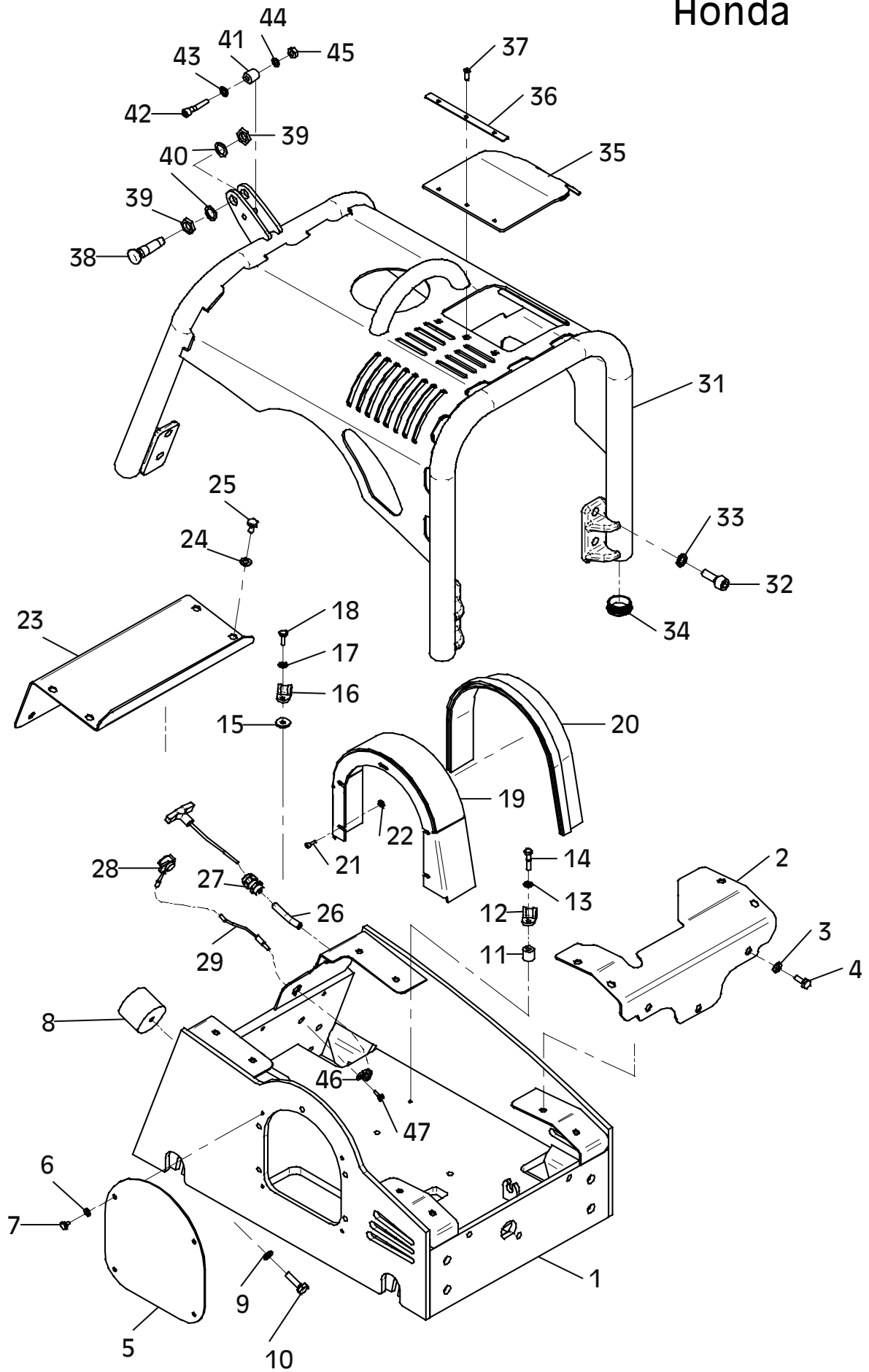

E 3092-0503

E 3093-0404

Position Ref.No. Repère Posizione Posicion	Menge Quantity Quantité Quantità Cantidad	Teile-Nr. Part-No. No. Référence Nr. d'Ordine No. Referenzia	Hinweis Hints Indications Indicazione Indicaciones	Position Ref. No. Repère Posizione Posicion	Menge Quantity Quantité Quantità Cantidad	Teile-Nr. Part-No. No. Référence Nr. d'Ordine No. Referenzia	Hinweis Hints Indications Indicazione Indicaciones
1	1	20001239		30	1	10016539	
2	2	10016980		31	2	20029015	VSKZ 6
3	3	25033027	DIN603-M10x60	32	2	25044002	DIN912-M6x16
4	1	25033019	DIN603-M10x70				
5	3	25049020	DIN7349-10,5				
6	3	20029025					
7	3	25031004	DIN934-M10				
8	1	25049020	DIN7349-10,5				
9	1	25031004	DIN934-M10				
10	2	25048003	DIN125-A10,5				
11	1	20022003	Tensilock M10				
12	1	20025702					
13	1	25008016	DIN 7603-14x18x1,5				
14	1	20025704					
15	1	20025434					
16	1	20026559					
17	1	20007024					
18	1	10016864					
19	4	20029001	VSK 10				
20	4	25042006	3/8"-16UNC				
21	1	20002091					
22	1	25002175					
23	1	20026475					
24	1	25038012	DIN933-M8x45				
25	1	10022586					
26	2	25049036	VSF 8				
27	2	25038006	DIN933-M8x16				
28	1	10022625					
29	1	20007086					

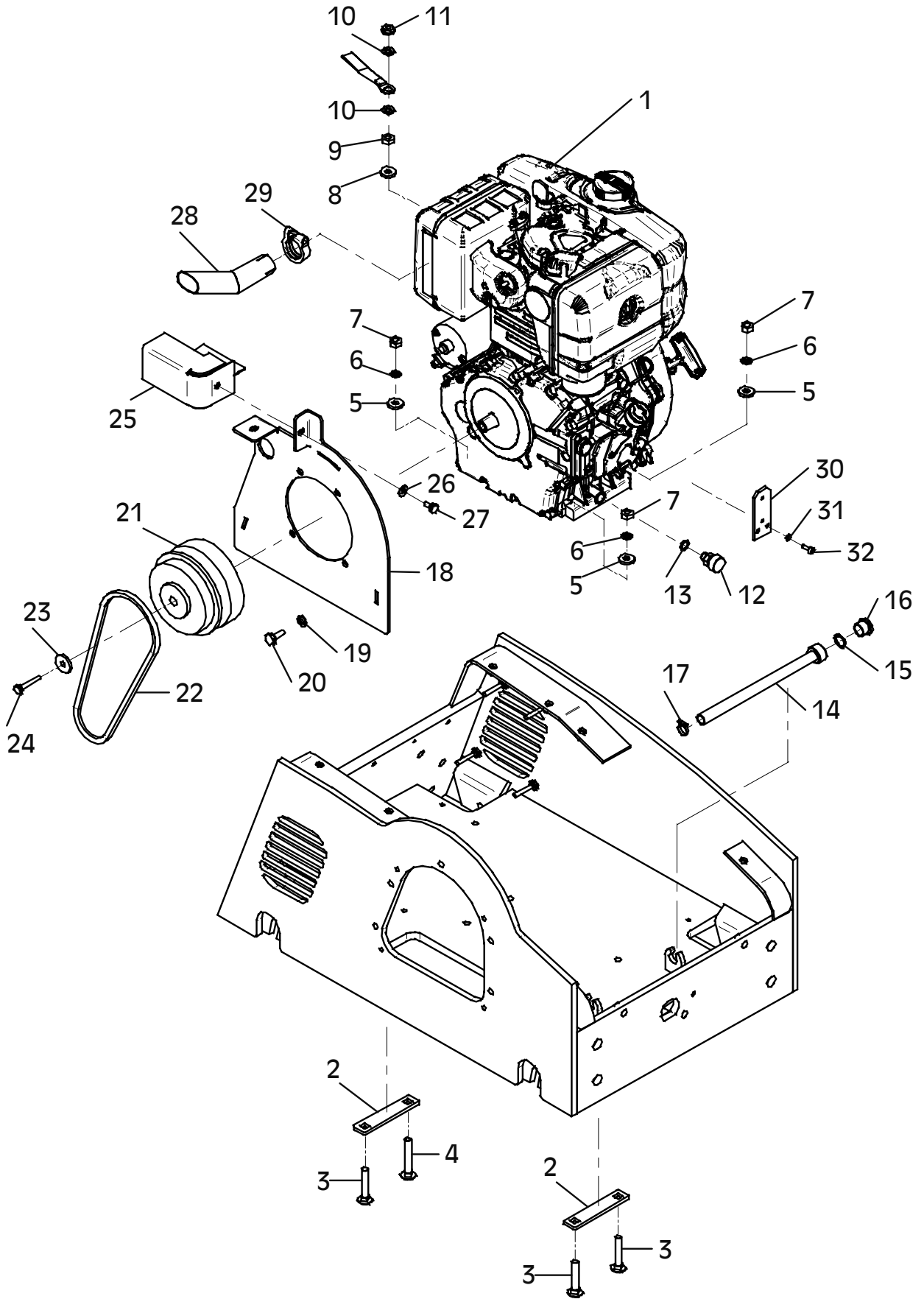

E 3094-0403

Position Ref.No. Repère Posizione Posicion	Menge Quantity Quantité Quantita Cantidad	Teile-Nr. Part-No. No. Référence Nr. d'Ordine No. Referenzia	Hinweis Hints Indications Indicazione Indicaciones	Position Ref. No. Repère Posizione Posicion	Menge Quantity Quantité Quantita Cantidad	Teile-Nr. Part-No. No. Référence Nr. d'Ordine No. Referenzia	Hinweis Hints Indications Indicazione Indicaciones
1	1	20002091					
2	2	20002268					
3	2	20002289					

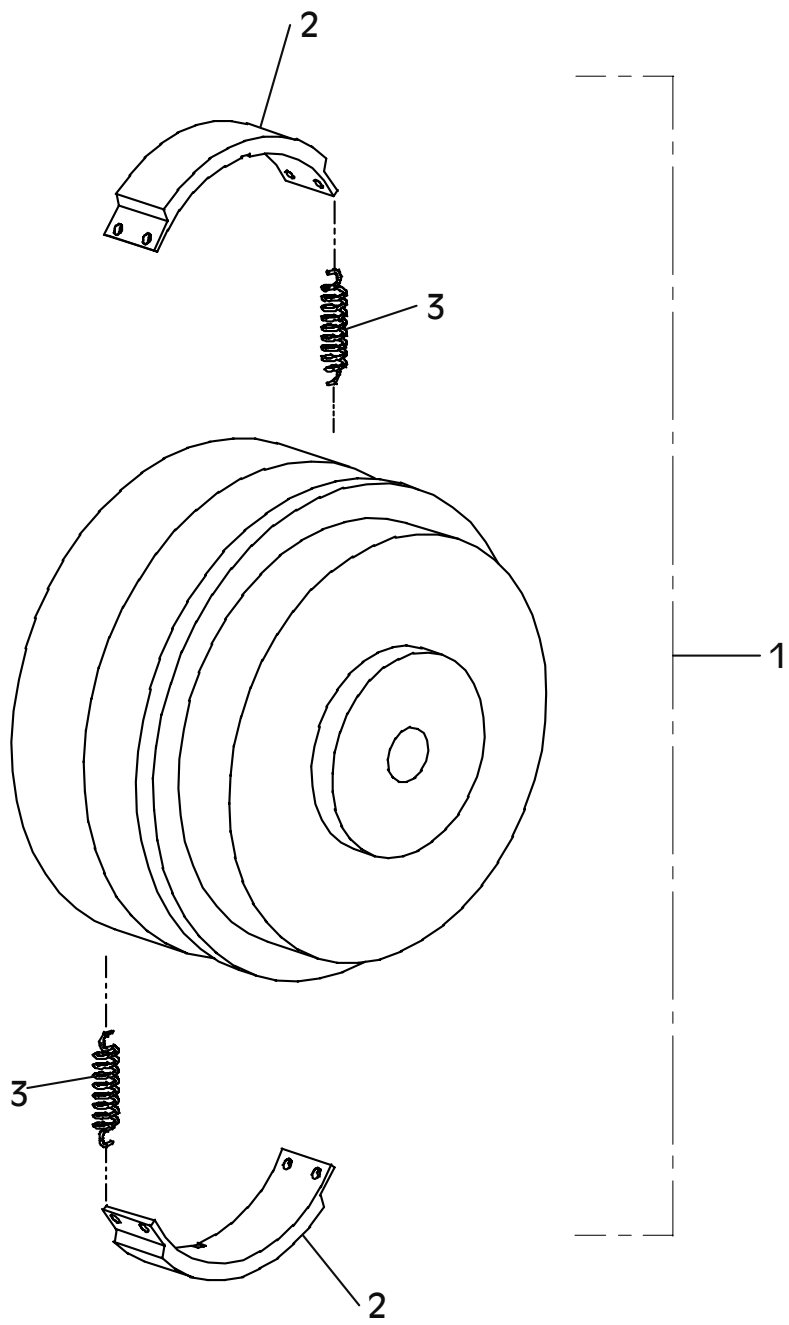

E 3095-0503

Position Ref.No. Repère Posizione Posicion	Menge Quantity Quantité Quantità Cantidad	Teile-Nr. Part-No. No. Référence Nr. d'Ordine No. Referenzia	Hinweis Hints Indications Indicazione Indicaciones	Position Ref. No. Repère Posizione Posicion	Menge Quantity Quantité Quantità Cantidad	Teile-Nr. Part-No. No. Référence Nr. d'Ordine No. Referenzia	Hinweis Hints Indications Indicazione Indicaciones
1	1	20001119		30	1	25038002	DIN933-M6x16
2	2	10016980		31	1	40001338	
3	4	25033019	DIN603-M10x70	32	1	20007007	
4	4	25049020	DIN7349-10,5	33	1	25038072	DIN933-M6x12
5	4	20029025					
6	4	25031004	DIN934-M10				
7	1	25008011					
8	1	20026204					
9	1	20025704					
10	1	20025434					
11	1	20026559					
12	1	20007024					
13	1	30047431					
14	4	20025122					
15	4	25038006	DIN933-M8x16				
16	1	20002097					
17	1	25002175					
18	1	10017040					
19	1	20026475					
20	1	25040065	DIN931-M8x40				
21	1	20015175					
22	1	10017036					
23	1	25038002	DIN933-M6x16				
24	1	20029007	VSK 6				
25	1	25044065	DIN912-M6x25				
26	1	20029007	VSK 6				
27	1	25031002	DIN934-M6				
28	1	20007007					
29	1	25048001	DIN125-B6,4				

Honda

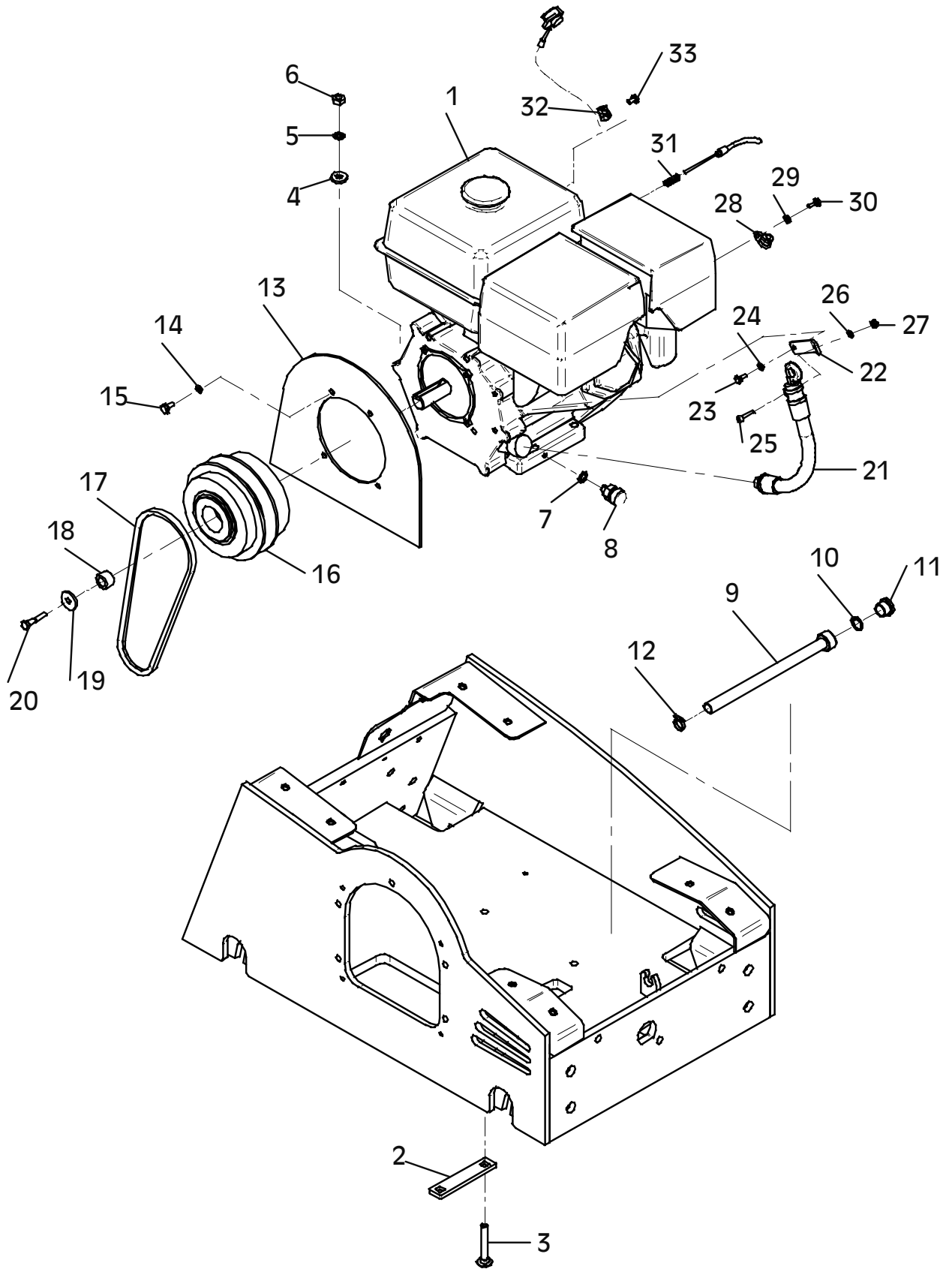

E 3095-0503

E 3096-0503

Position Ref.No. Repère Posizione Posicion	Menge Quantity Quantité Quantita Cantidad	Teile-Nr. Part-No. No. Référence Nr. d'Ordine No. Referenzia	Hinweis Hints Indications Indicazione Indicaciones	Position Ref. No. Repère Posizione Posicion	Menge Quantity Quantité Quantita Cantidad	Teile-Nr. Part-No. No. Référence Nr. d'Ordine No. Referenzia	Hinweis Hints Indications Indicazione Indicaciones
1	1	20002097					
2	2	20002268					
3	2	20002289					

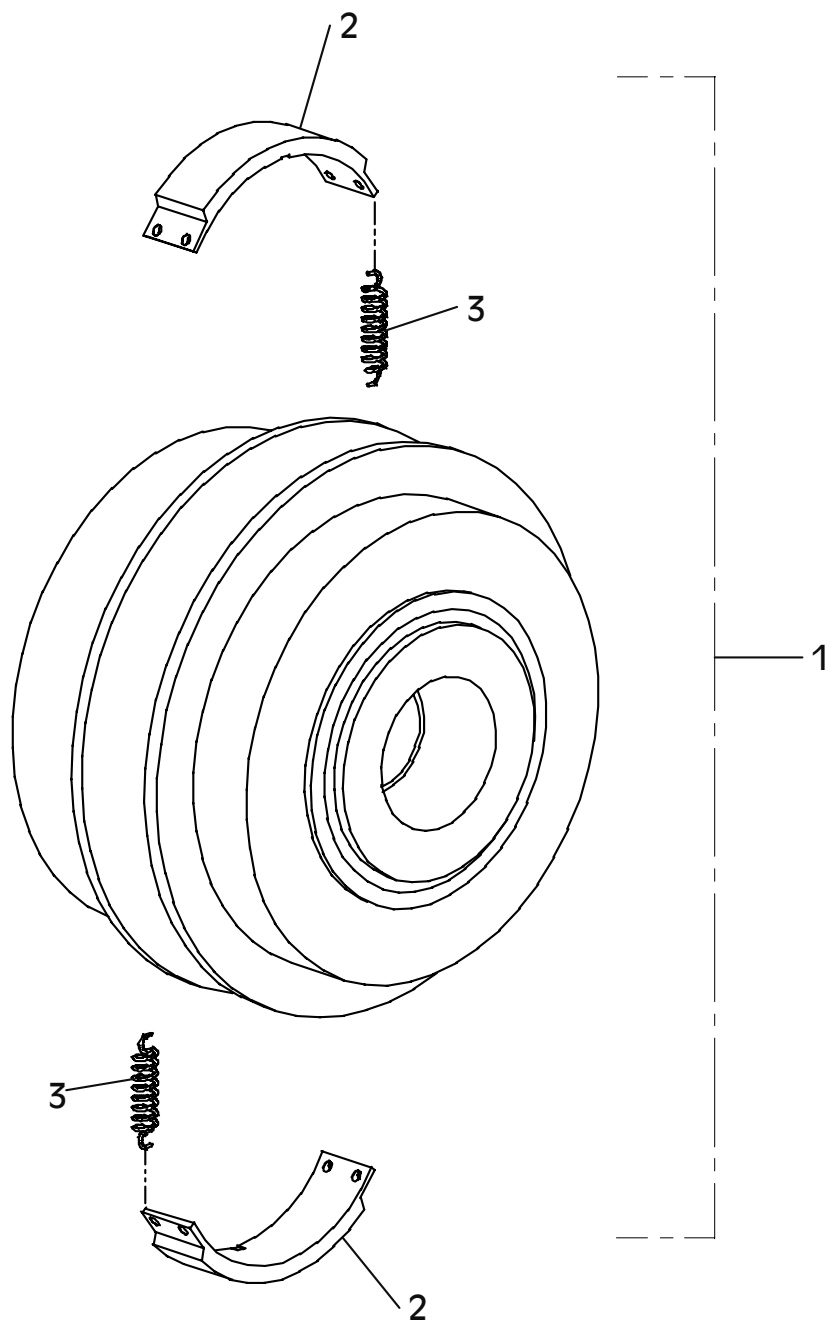

E 3096-0503

E 3097-0403

Position Ref.No. Repère Posizione Posicion	Menge Quantity Quantité Quantita Cantidad	Teile-Nr. Part-No. No. Référence Nr. d'Ordine No. Referenzia	Hinweis Hints Indications Indicazione Indicaciones	Position Ref. No. Repère Posizione Posicion	Menge Quantity Quantité Quantita Cantidad	Teile-Nr. Part-No. No. Référence Nr. d'Ordine No. Referenzia	Hinweis Hints Indications Indicazione Indicaciones
1	1	10022585		34	2	10016304	
2	1	30047382		35	2	20013283	
3	6	20029021	SKB 8	36	2	10022521	
4	6	25038008	DIN933-M8x25	37	2	20026468	
5	2	10016859		38	2	20029023	SKB 12
6	4	25044055	DIN912-M8x50	39	2	25038020	DIN933-M12x30
7	4	20029003	VSK 8	40	1	20008069	
8	4	25031003	DIN934-M8	41	1	10016307	
9	2	20026491		42	1	20013282	
10	2	10016291		43	2	20013285	
11	2	20029002	VSK 16	44	1	10016305	
12	2	25040066	DIN931-M16x55	45	1	20013286	
13	2	20026492		46	1	10016303	
14	2	20004016		47	1	10016308	
15	2	10016857		48	2	25047022	DIN7991-M6x12
16	4	20029029		49	4	20025122	
17	4	25044039	DIN912-M16x40	50	4	25044006	DIN912-M8x25
18	4	20029003	VSK 8	51	1	20018143	
19	4	25040056	DIN931-M8x25	52	1	20020562	
20	1	20007089		53	1	20016367	
21	1	10016402	Lombardini	54	1	20018157	Lombardini
21	1	10017045	Honda	54	1	20018160	Honda
22	1	25048002	DIN125-A8,4	55	1	20018082	
23	1	25040004	DIN931-M8x55	56	1	20018158	Lombardini
24	1	20007089		56	1	20018161	Honda
25	1	10015676	Lombardini	57	1	10016938	Lombardini
25	1	10017044	Honda	57	1	10016100	Honda
26	1	20029003	VSK 8	58	2	20029007	
27	1	25040027	DIN931-M8x35	59	2	25040067	DIN931-M6x30
28	1	10016309					
29	1	25008019					
30	1	25030018	DIN908-M26x1,5				
31	1	20025764					
32	1	10016306					
33	2	20013284					

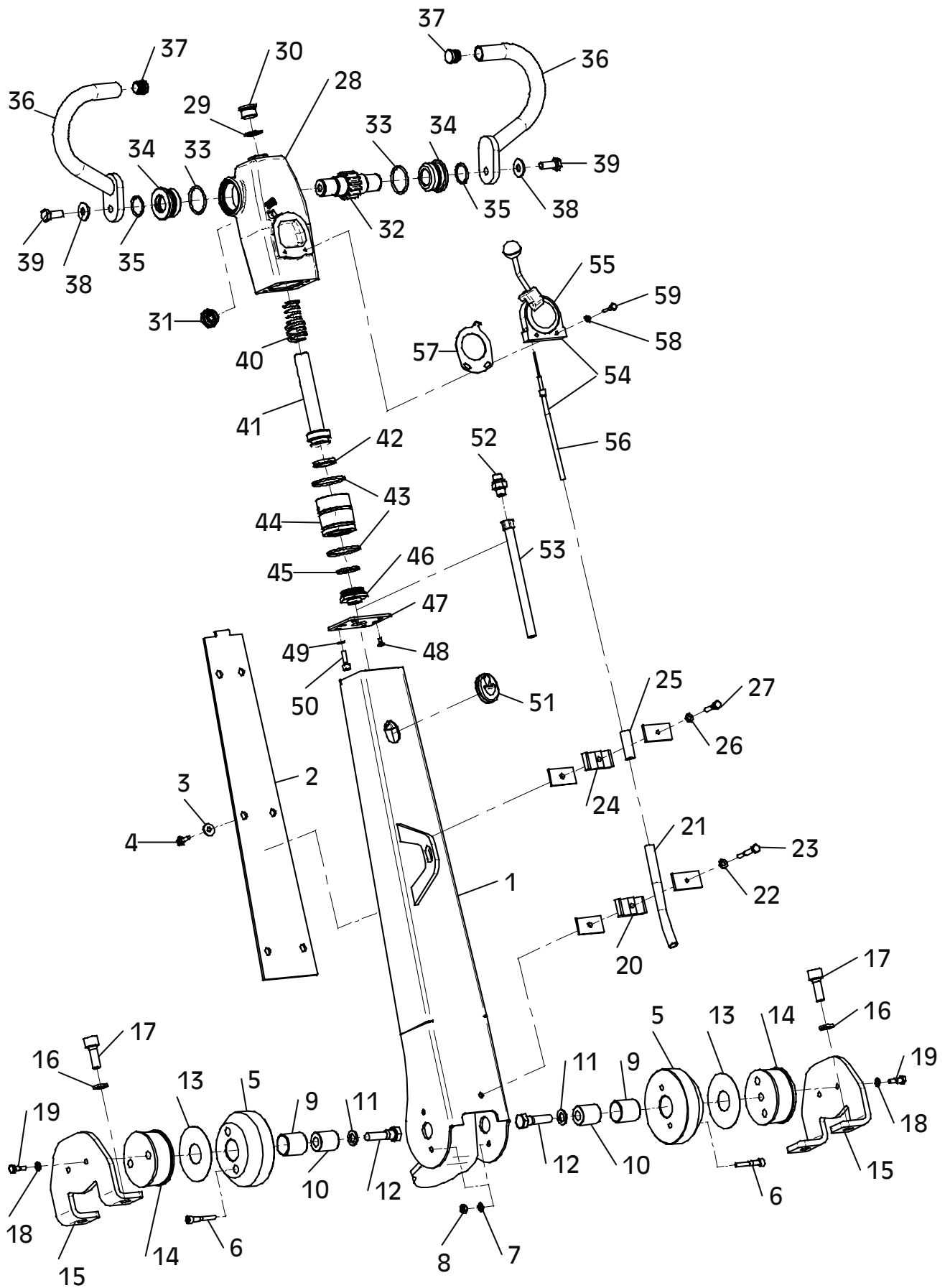

E 3097-0403

E 3098-0403

Position Ref.No. Repère Posizione Posicion	Menge Quantity Quantité Quantita Cantidad	Teile-Nr. Part-No. No. Référence Nr. d'Ordine No. Referenzia	Hinweis Hints Indications Indicazione Indicaciones	Position Ref. No. Repère Posizione Posicion	Menge Quantity Quantité Quantita Cantidad	Teile-Nr. Part-No. No. Référence Nr. d'Ordine No. Referenzia	Hinweis Hints Indications Indicazione Indicaciones
1	1	10003989					
2	2	20029003	VSK 8				
3	2	25038007	DIN933-M8x20				
4	1	20031502					
5	2	10016930					
6	2	10015530					
7	1	10015675					
8	1	10001433					
9	1	20025566					
10	1	10015828					
11	1	10015631					
12	2	25020035					
13	10	25031003	DIN934-M8				
14	4	20029003	VSK 8				
15	1	10001449					
16	2	20029020	SKB 6				
17	2	25038003	DIN933-M6x20				
18	1	10001448					
19	2	25023027	DIN84-M3x10				
20	2	25048029	DIN125-B3,2				
21	2	25031048	DIN934-M3				
22	1	40080599					
23	1	20031532					
24	2	25048017	DIN125-A5,3				
25	2	25038038	DIN933-M5x16				
26	2	25031023	DIN985-M5				
27	1	20031541					

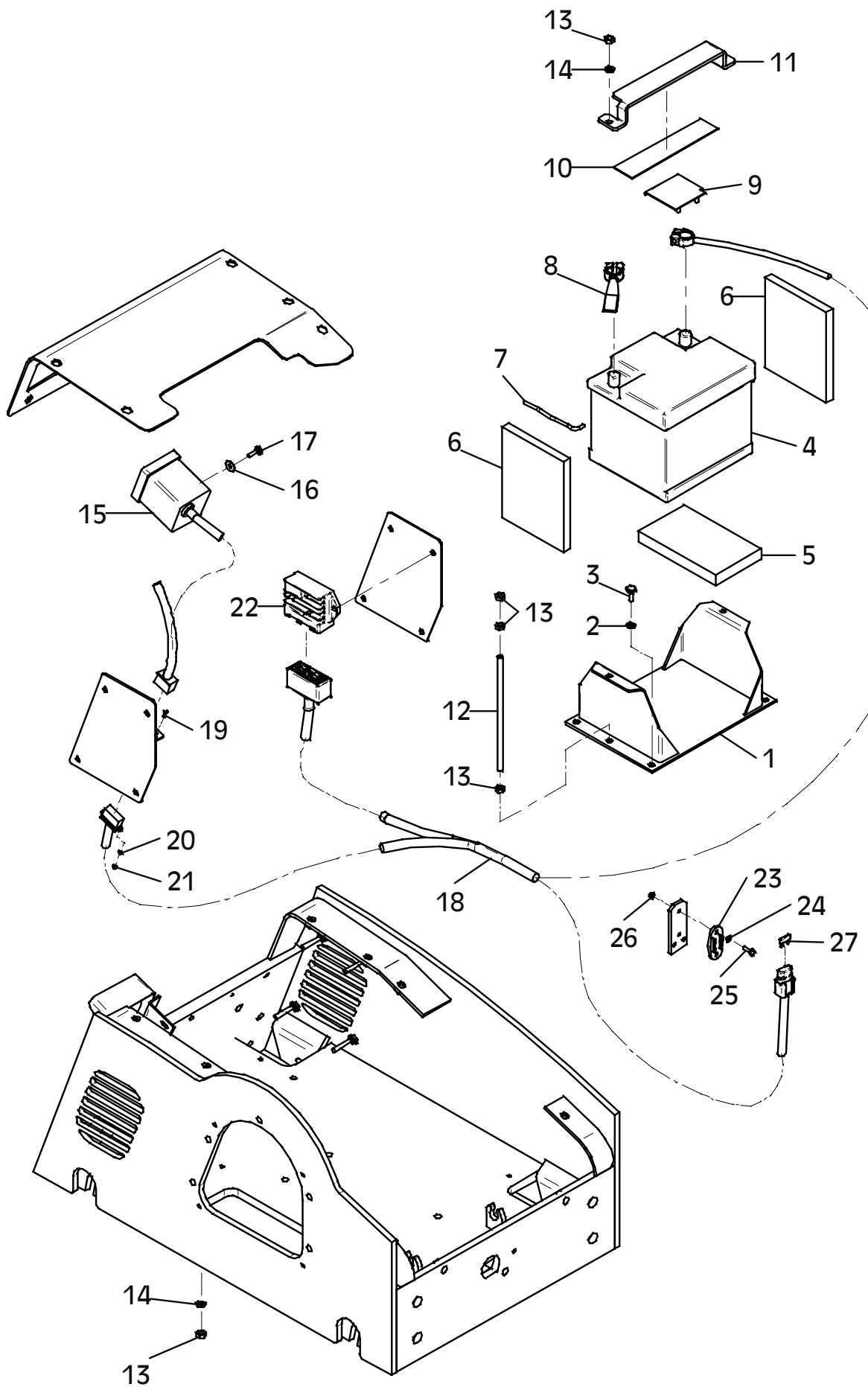

E 3098-0403

E 3099-0403

Position Ref.No. Repère Posizione Posicion	Menge Quantity Quantité Quantità Cantidad	Teile-Nr. Part-No. No. Référence Nr. d'Ordine No. Referenzia	Hinweis Hints Indications Indicazione Indicaciones	Position Ref. No. Repère Posizione Posicion	Menge Quantity Quantité Quantità Cantidad	Teile-Nr. Part-No. No. Référence Nr. d'Ordine No. Referenzia	Hinweis Hints Indications Indicazione Indicaciones
1	1	10016967					
2	2	10016968					
3	6	25040049	DIN931-M12x80				
4	6	20029004	VSK 12				
5	6	25031005	DIN934-M12				

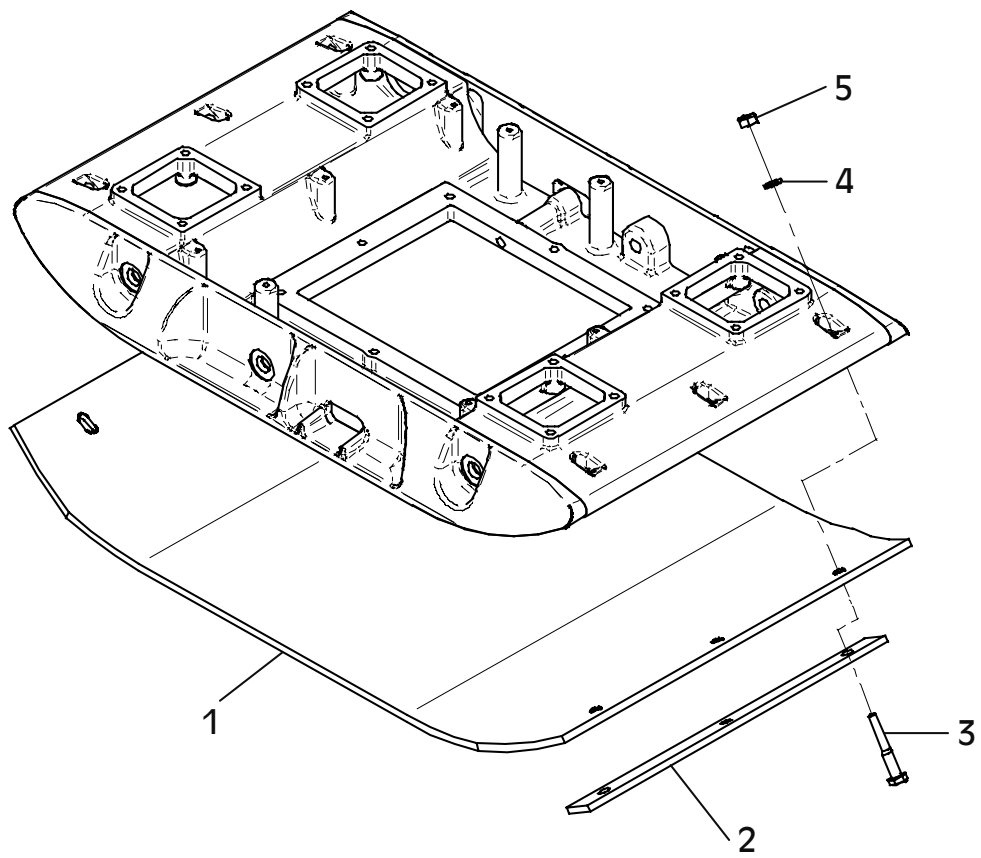

E 3099-0403

E 3100-0403

Position Ref.No. Repère Posizione Posicion	Menge Quantity Quantité Quantità Cantidad	Teile-Nr. Part-No. No. Référence Nr. d'Ordine No. Referenzia	Hinweis Hints Indications Indicazione Indicaciones	Position Ref. No. Repère Posizione Posicion	Menge Quantity Quantité Quantità Cantidad	Teile-Nr. Part-No. No. Référence Nr. d'Ordine No. Referenzia	Hinweis Hints Indications Indicazione Indicaciones
1	1	10016969					
2	2	10016970					
3	6	25040049	DIN931-M12x80				
4	6	20029004	VSK 12				
5	6	25031005	DIN934-M12				
6	2	10016759					
7	6	20029009	VSK 20				
8	2	25038032	DIN933-M20x40				
9	4	25038085	DIN933-M20x100				

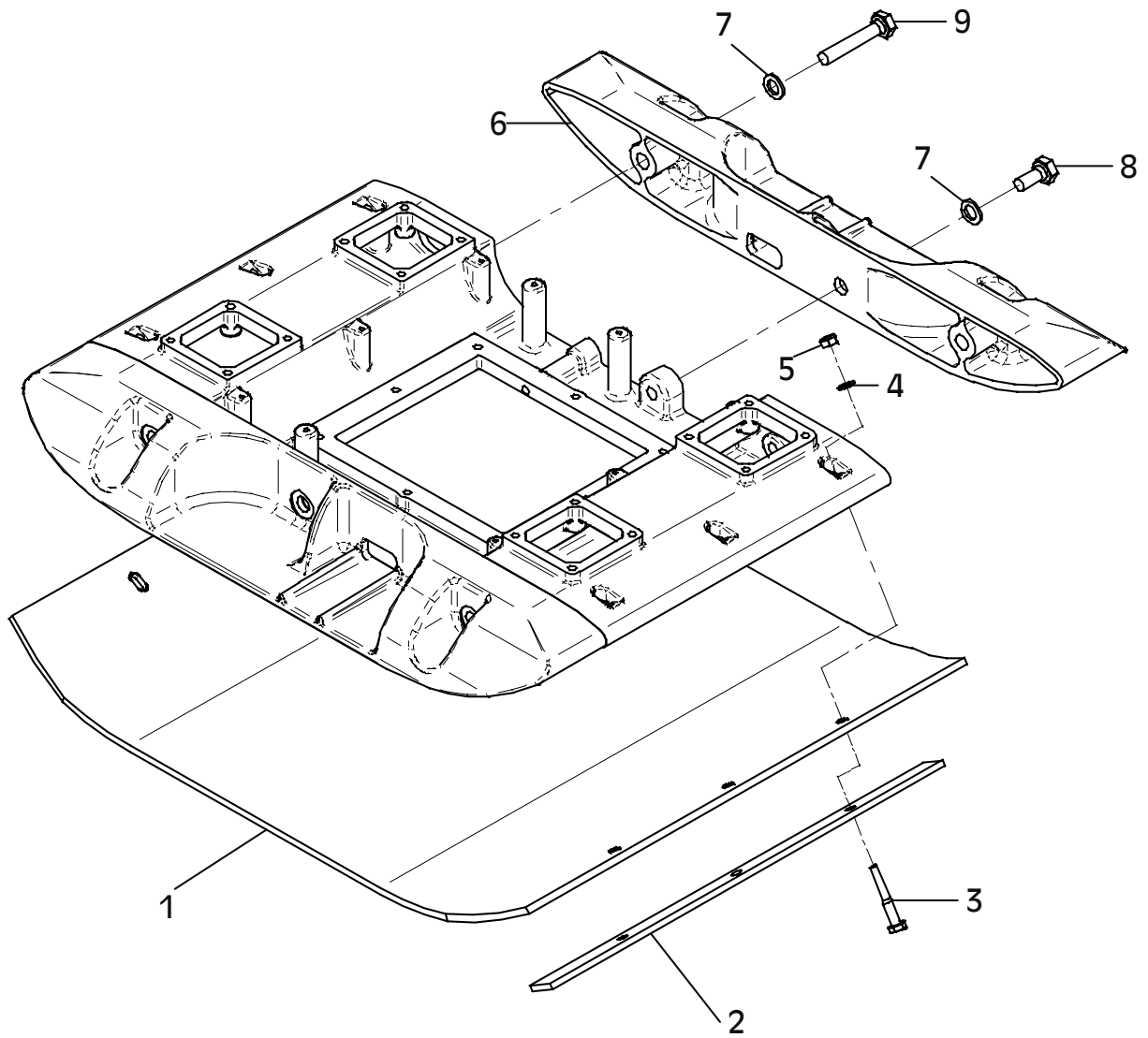

E 3100-0403

E 3101-0403

Position Ref.No. Repère Posizione Posicion	Menge Quantity Quantité Quantita Cantidad	Teile-Nr. Part-No. No. Référence Nr. d'Ordine No. Referenzia	Hinweis Hints Indications Indicazione Indicaciones	Position Ref. No. Repère Posizione Posicion	Menge Quantity Quantité Quantita Cantidad	Teile-Nr. Part-No. No. Référence Nr. d'Ordine No. Referenzia	Hinweis Hints Indications Indicazione Indicaciones
1	2	10016971					
2	6	20029009	VSK 20				
3	6	25038032	DIN933-M20x40				

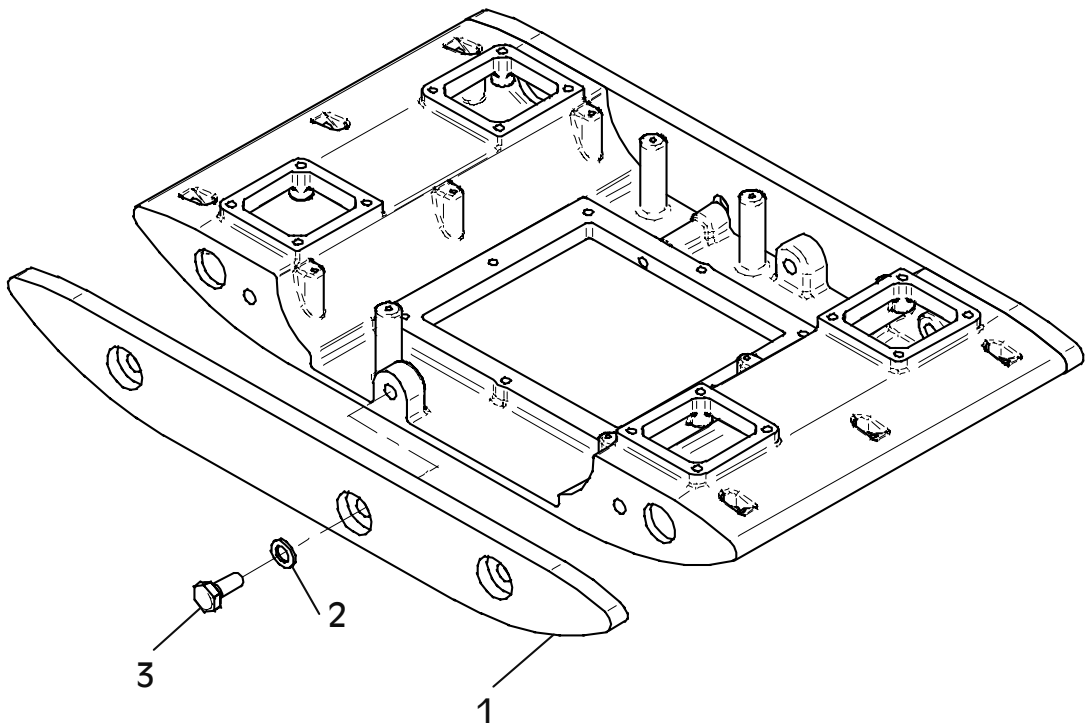

E 3101-0403

**Wenn Sie Fragen und Anregungen haben, oder sonstige Informationen benötigen,
wenden Sie sich bitte an eine der unten genannten Adressen:**

**For questions and further information refer to one of the
following addresses:**

<p>In Deutschland</p> <p>In Germany</p>	<p>WEBER Maschinenteknik GmbH Postfach 2153 57329 Bad Laasphe – Rückershausen</p> <p>Information / information: E-mail: info@webermt.de</p> <p>Ersatzteile / spare parts: E-mail: parts@webermt.de</p>	<p>Telefon / phone:</p> <p>Telefax / fax:</p> <p>Telefax / fax:</p>	<p>+49 (0) 2754 / 3980 Zentrale / switchboard</p> <p>+49 (0) 2754 / 398101 Zentrale / switchboard</p> <p>+49 (0) 2754 / 398102 Ersatzteile / spare parts direct dial</p>
<p>In Holland</p> <p>In Netherlands</p>	<p>WEBER Maschinenteknik B.V. Graafschap Hornelaan 159 6001 AC Weert</p> <p>E-mail: info@webermt.nl</p>	<p>Telefon / phone:</p> <p>Telefax / fax:</p>	<p>+31 (0) 495 / 530215</p> <p>+31 (0) 495 / 541839</p>
<p>In Frankreich</p> <p>In France</p>	<p>WEBER Technologie S.A.R.L. 26, rue d'Arsonval 69680 Chassieu</p> <p>E-mail: france@webermt.com</p>	<p>Telefon / phone:</p> <p>Telefax / fax:</p>	<p>+33 (0) 472 / 791020</p> <p>+33 (0) 472 / 791021</p>
<p>In Polen</p> <p>In Poland</p>	<p>WEBER Maschinenteknik SP.ZO.O. ul. Grodziska 7 05-830 Stara Wies / Nadarzyn</p> <p>E-mail: info@webermt.com.pl</p>	<p>Telefon / phone:</p> <p>Telefax / fax:</p>	<p>+48 (0) 22 / 7397080 +48 (0) 22 / 7397081</p> <p>+48 (0) 22 / 7397082</p>
<p>In USA, Kanada</p> <p>In USA, Canada</p>	<p>WEBER Machine (USA), Inc. 40 Johnson Ave 112 Bangor, ME 04401 USA</p> <p>E-mail: usa@webermt.com</p>	<p>Telefon / phone:</p> <p>Telefax / fax:</p>	<p>+1 (0) 207 / 9474990</p> <p>+1 (0) 207 / 9475452</p>
<p>In Südamerika</p> <p>In South America</p>	<p>WEBER Maschinenteknik do Brasil Ltda. Rua Sete de Setembro, 275 93332-470 Novo Hamburgo, RS Brasil</p> <p>E-mail: webermt@webermt.com.br</p>	<p>Telefon / phone:</p> <p>Telefax / fax:</p>	<p>+55 (0) 51 / 5873044</p> <p>+55 (0) 51 / 5872271</p>

<http://www.webermt.com>

