



ERSATZTEILLISTE

SPARE PARTS LIST

LISTE DES PIECES
DE RECHANGE

LISTINO RICAMBI

LISTA DE RECAMBIOS

WYKAZ CZESCI
ZAMIENNYCH



CR 8

011641



Weber Maschinentechnik GmbH
Postfach 2153, 57329 Bad Laasphe-Rückershausen
Telefon 02754 / 398-0
Telefax (02754) 398-101 (Zentrale) u. 398-102 (Ersatzteile)

EG - KONFORMITÄTSERKLÄRUNG
EC DECLARATION OF CONFORMITY/ DECLARATION DE CONFORMITE CE
DICHIARAZIONE CE DI CONFORMITA / DECLARACION CE DE CONFORMIDAD
EG-VERKLARING VAN OVEREENSTEMMING / EF-OVERENSSTEMMELSESERKAERING
DECLARACAO CE DE CONFORMIDADE / EG-FÖRSÄKRAN OM ÖVERENSSTÄMMELSE

**im Sinne der EG-Maschinenrichtlinie 98/37/EG
und der EG Richtlinie 2000/14/EG – Geräuschemissionen**

- I **Art / Category / Catégorie / Categoria Tipo / Kategori /**
Soort / Categoria / kategori
- II **Hersteller (Typ) / Make (Type) / Marque (Type) / Marca (Tipo) /**
Marca (Codice) / Producent (Type) / Merk (Type) / Marca (Tipo) /
Tillverkare (Typ)
- III **gemessener Schalleistungspegel / measured sound power level / niveau de**
puissance acoustique mesure / livello di potenza sonora rilevato / nivel de
potencia acústica medido / gemeten geluidsvermogensniveau / målt
lydeffektniveau / Nivel de potência sonora midido / uppmätt ljudeffektnivå
- IV **garantierter Schalleistungspegel / guaranteed sound power level / niveau de**
puissance acoustique garanti / livello di potenza sonora garantito / nivel de
potencia acustica garantizado / gewaarborgd geluidsvermogensniveau /
garanteret lydeffektniveau / Nivel sonoro garantido / garanterad ljudeffektniva
- V **beteiligte Zertifizierungsstelle / notified body involved / de l'organisme**
notifié/ dell'organismo notificato che l'ha effettuata / dirección del organismo
notificado que haya intervenido / betrokken aangemelde instantie / pagældende
bemyndigede organ / organismo notificado involucrado / berörda anmälda
organets namn
- VI **Konformitäts-Bewertungsverfahren / Conformity assessment procedure**
followed / la procédure appliquée pour l'évaluation de la conformité et /
procedura di valutazione della conformità / procedimiento de evaluación de la
conformidad / gevolgde overeenstemmingsbeoordelingsprocedure / den fulgte
overensstemmelssesvurderingsprocedure / procedimento de avaliacao de
conformidade / Vilket förfarande för bedömning av överensstämmelse

**Vibrationsplatte
CR 8**



LWA = 108 dB (A)

LWA = 109 dB (A)

**RWTÜV
Postfach 103161
D-45032 Essen**

**interne Fertigungskontrolle
nach Anhang VI
EG Richtlinie 2000/14/EG**

ist in Übereinstimmung mit folgenden Richtlinien hergestellt worden /has been produced in accordance with following standards / est produit conforme aux dispositions des directives europeenes ci-apres / ha sido fabricado en conformidad con las siguientes normas / é stato fabbricato in conformità alle sequenti norme / er blevet fremstillet i overensstemmelse med følgende retningslinier / in overeenstemming met de volgende voorschriften gefabriceerd is / é fabricado conforme as seguintes normas / har tillverkats i överensstämmelse med följande riktlinjer

98/37/EG	Maschinenrichtlinie des europäischen Parlamentes und des Rates vom 22. Juni 1998
2000/14/EG	EG-Richtlinie Geräuschemissionen vom 8. Mai 2000
EN 500 Teil 1	Bewegliche Straßenbaumaschinen – Sicherheit Gemeinsame Anforderungen
EN 500 Teil 4	Bewegliche Straßenbaumaschinen – Sicherheit Besondere Anforderungen an Verdichtungsmaschinen

Bescheinigung bitte sorgfältig aufbewahren / File certificate carefully / Conserver certificat soigneusement / Conservar certificado cuidadosamente / Pregasi conservare accuratamente certificato / Beviset bedes opbevares omhyggeligt / Verklaring a.u.b. zorgvuldig bevar / Conservar o certificado com cuidado / Beviset skall om sorgsfullt bevaras

Bad Laasphe – Rückershausen, den **02.01.2002**

W. Weber, Geschäftsführer



WEBER Maschinentechnik GmbH
Im Boden 5-8, 10 – D-57334 Bad Laasphe
Postfach 2153 – D-57329 Bad Laasphe
Telefon: 02754/398-0 – Fax 02754/398-101
E-mail: Verkauf@webermt.de
Internet: <http://www.webermt.de>



BITTE, NOTIEREN SIE SERIENNUMMER UND MOTORNUMMER IHRER MASCHINE:

PLEASE WRITE DOWN SERIALNUMBERS OF MACHINE AND ENGINE:

NOTEZ SVP LE NUMERO DE SERIE ET LE NUMERO DU MOTEUR DE VOTRE MACHINE:

SI PREGA DI ANNOTARE SEMPRE I NUMERI DI SERIE SIA DELLA VS. MACCHINA CHE DEL MOTORE:

MAQUINA: ROGAMOS ANOTEN EL NUMERO DE SERIE Y NUMERO DE MOTOR DE SU MAQUINA:

MASCHINE
MACHINE
MACCHINA
MAQUINA

MOTOR
ENGINE
MOTEUR
MOTORE

ZUR VERMEIDUNG VON FEHLLIEFERUNGEN UND VERZÖGERUNGEN SIND BEI DER BESTELLUNG VON ERSATZTEILEN FOLGENDE ANGABEN UNBEDINGT ERFORDERLICH:

- MASCHINENTYP
- SERIENNUMMER DER MASCHINE
- SERIENNUMMER DES MOTORS (BEI MOTORTEILEN)
- TEILENUMMER
- BESTELLMENGE

TO AVOID ERRORS IN DELIVERY PLEASE STATE THESE PARTICULARS WHEN ORDERING:

- TYPE OF MACHINE
- SERIAL NO. OF MACHINE
- SERIAL NO. OF ENGINE (ON ENGINE PARTS)
- PART-NO.
- QUANTITY REQUIRED

AFIN D'EVITER DES ERREURS DE COMMANDE ET DES RETARDS DE LIVRAISON IL EST NECESSAIRE D'INDIQUER LES CARACTERISTIQUES SUIVANTES:

- TYPE DE MACHINE
- LE NUMERO DE SERIE DE LA MACHINE
- LE NUMERO DE SERIE DU MOTEUR
- LE NUMERO D'IDENTITE DE LA PIECE
- LA QUANTITE SOUHAITEE

ONDE EVITARE DISGUIDI E RITARDI NELLE CONSEGNE DIE RICAMBI SI PREGA DI INDICARE SEMPRE:

- TIPO DELLA MACCHINA
- NUMERO DI SERIE DELLA MACCHINA
- NUMERO DI SERIE DEL MOTORE (SE SI RICHIEDONO PEZZI DEL MOTORE)
- NUMERO D'ORDINE DIE SINGOLI RICAMBI
- QUANTITA

A FI DE EVITAR ERRORES DE ENTREGA, ROGAMOS INDIQUEN LOS SIGUIENTES DATOS CUANDO PASE PEDIDOS DE RECAMBIO:

- MODELO DE MAQUINA
- NO. DE SERIE DE LA MAQUINA
- NO. DE SERIE DEL MOTOR (EN PIEZAS PARA MOTOR)
- REFERENCIA DEL RECAMBIO
- CANTIDAD PEDIDA

E 3000-1001

Position Ref.No. Repère Posizione Posicion	Menge Quantity Quantité Quantità Cantidad	Teile-Nr. Part-No. No. Référence Nr. d'Ordine No. Referenzia	Hinweis Hints Indications Indicazione Indicaciones	Position Ref. No. Repère Posizione Posicion	Menge Quantity Quantité Quantità Cantidad	Teile-Nr. Part-No. No. Référence Nr. d'Ordine No. Referenzia	Hinweis Hints Indications Indicazione Indicaciones
1	1	10016160					
2	8	20026485					
3	1	25030002	DIN908-M14x1,5				
4	2	10016161					
5	6	20029009	VSK 20				
6	6	25038027	DIN933-M20x50				
7	2	10016162					
8	2	10016163					
9	12	20025158					
10	12	25038021	DIN933-M12x35				
11	4	20004012					
12	8	25049019	DIN7349-17x40x6				
13	8	20029002	VSK 16				
14	4	25031006	DIN934-M16				
15	4	25025009					
16	4	10016367					
17	4	10001423					
18	4	20025158					
19	4	20005018					
20	1	20013289					
21	1	20013288					
22	1	20013287					
23	6	20029011	VSKZ 8				
24	6	25044007	DIN912-M8x30				
25	1	10001444					
26	8	20029026					
27	6	25045033	DIN912-M12x140				
28	2	25045034	DIN912-M12x170				

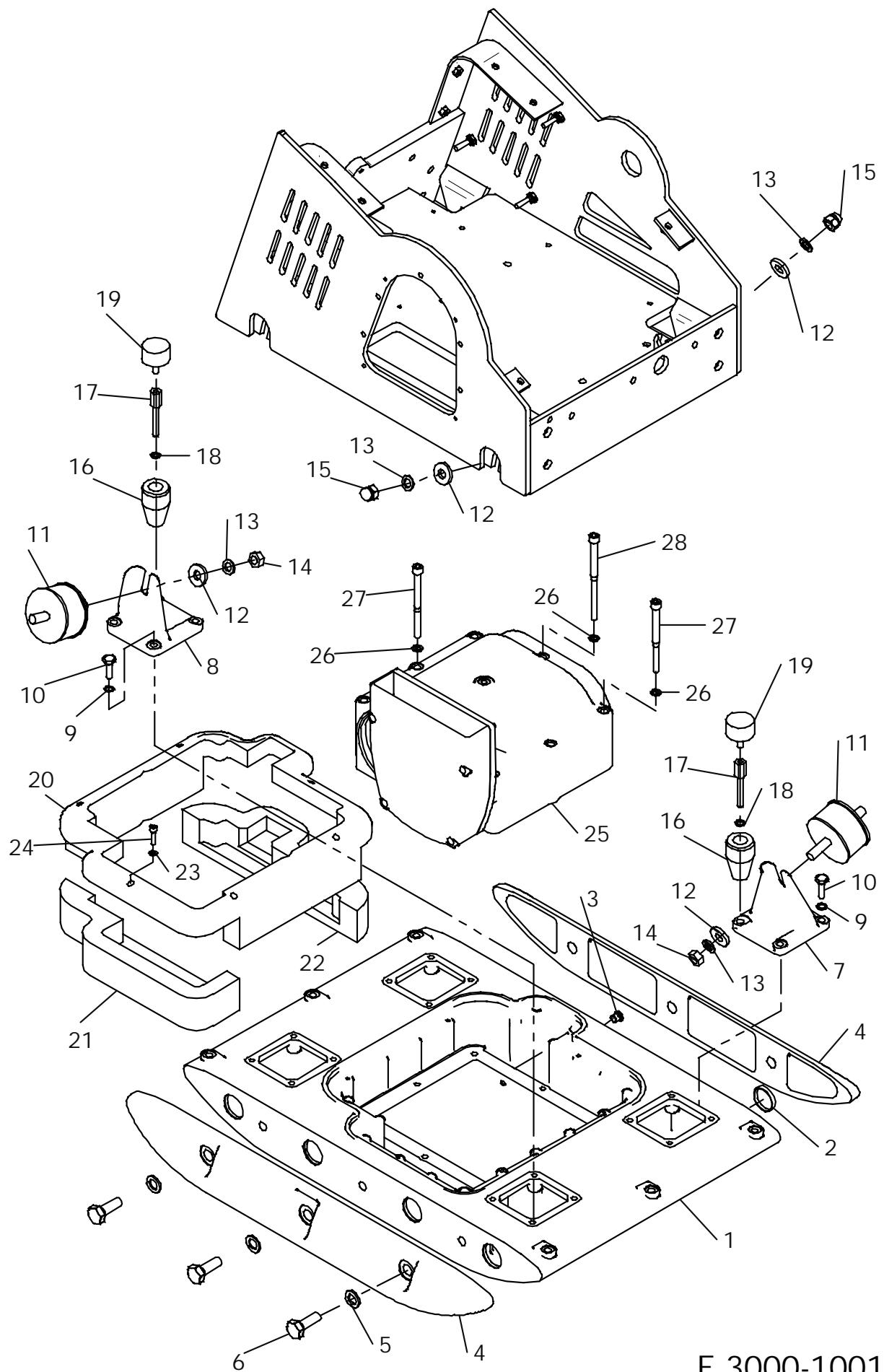

E 3000-1001

E 3001-0802

Position Ref.No. Repère Posizione Posicion	Menge Quantity Quantité Quantita Cantidad	Teile-Nr. Part-No. No. Référence Nr. d'Ordine No. Referenzia	Hinweis Hints Indications Indicazione Indicaciones	Position Ref. No. Repère Posizione Posicion	Menge Quantity Quantité Quantita Cantidad	Teile-Nr. Part-No. No. Référence Nr. d'Ordine No. Referenzia	Hinweis Hints Indications Indicazione Indicaciones
1	1	10016164		30	1	10016388	
2	1	25038042	DIN933-M12x16	31	1	10007370	
3	1	25008011		32	1	20029001	VSK 10
4	1	10016165		33	1	10016382	
5	4	25044010	DIN912-M8x65	34	2	25001701	
6	4	20029011	VSKZ 8	35	1	10016826	
7	2	10016167		36	2	25025157	
8	8	25044005	DIN912-M8x20	37	2	25045035	DIN912-M12x50
9	8	20029011	VSKZ 8	38	1	10016386	
10	2	20013290		39	2	25001702	
11	1	10016166		40	1	10016171	
12	4	25044005	DIN912-M8x20	41	1	10016383	
13	4	20029011	VSKZ 8	42	1	10016385	
14	1	25017201		43	1	25029015	
15	1	20013290		44	1	25028004	DIN915-M10x25
16	1	10016168		45	1	25035018	DIN472-I32
17	4	25044005	DIN912-M8x20	46	1	25001703	
18	4	20029011	VSKZ 8	47	1	25034025	DIN471-A15x1
19	1	25030016	DIN910-M10x1	48	1	10016387	
20	1	25008012		49	1	20013275	
21	1	20013290		50	1	25030001	DIN908-M10x1
22	1	10016379		51	1	20020119	
23	2	25001701		52	0	25026027	
24	1	10016170		53	0	25026028	
25	1	25015076		54	0	25026029	
26	2	10016827					
27	2	25025157					
28	2	25045035	DIN912-M12x50				
29	1	10016828					

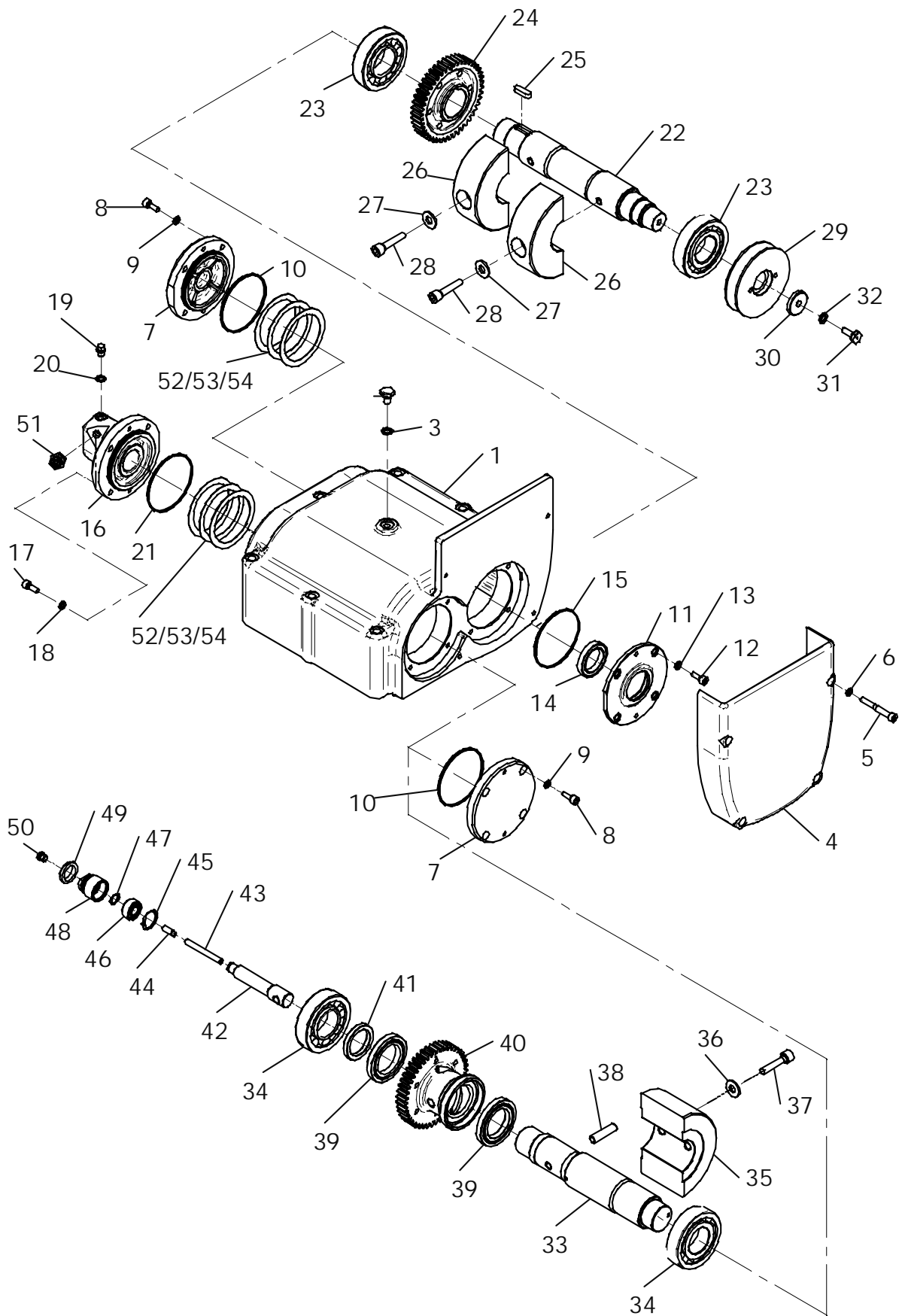

E 3001-0802

E 3002-0202

Position Ref.No. Repère Posizione Posicion	Menge Quantity Quantité Quantità Cantidad	Teile-Nr. Part-No. No. Référence Nr. d'Ordine No. Referenzia	Hinweis Hints Indications Indicazione Indicaciones	Position Ref. No. Repère Posizione Posicion	Menge Quantity Quantité Quantità Cantidad	Teile-Nr. Part-No. No. Référence Nr. d'Ordine No. Referenzia	Hinweis Hints Indications Indicazione Indicaciones
1	1	10022518		30	4	20029001	VSK 10
2	1	10016293		31	4	25031004	DIN934-M10
3	5	25044012	DIN912-M10x25	32	1	10022517	
4	5	25049035	VSF 10	33	9	25044012	DIN912-M10x25
5	1	10016301		34	9	25049035	VSF 10
6	4	25038006	DIN933-M8x16	37	1	25044099	DIN912-M10x50
7	4	20029003	VSK 8	38	2	25048003	DIN125-A10,5
8	4	25048002	DIN125-A8,4	40	1	25031014	DIN985-M10
9	1	20005006		41	1	20026481	
10	1	25049029	DIN1052-14x58x6	42	2	25025191	
11	1	20029004	VSK 12	43	2	20025019	
12	1	25038022	DIN933-M12x40	44	1	10016183	
13	1	10016292		45	1	25044012	DIN912-M10x25
14	2	20029022	SKB 10	46	1	25048003	DIN125-A10,5
15	2	25038013	DIN933-M10x20	47	1	20029022	SKB 10
16	1	10022536		48	1	25031004	DIN934-M10
17	6	25044002	DIN912-M6x16	49	1	10022526	
18	6	20022001	Tensilock M6	50	8	25044045	DIN912-M16x40
19	1	10016394		51	8	20029029	
20	1	10016415		52	4	20026482	
21	8	10016365		53	2	20026497	
22	1	10022541		54	2	20026496	
23	4	20029001	VSK 10	55	1	10016453	
24	4	25031004	DIN934-M10	56	1	10016454	
25	1	10016365		57	2	20026495	
26	1	20007077		58	2	20026494	
27	1	20029003	VSK 8				
28	1	25040065	DIN931-M8x40				
29	1	10016399					

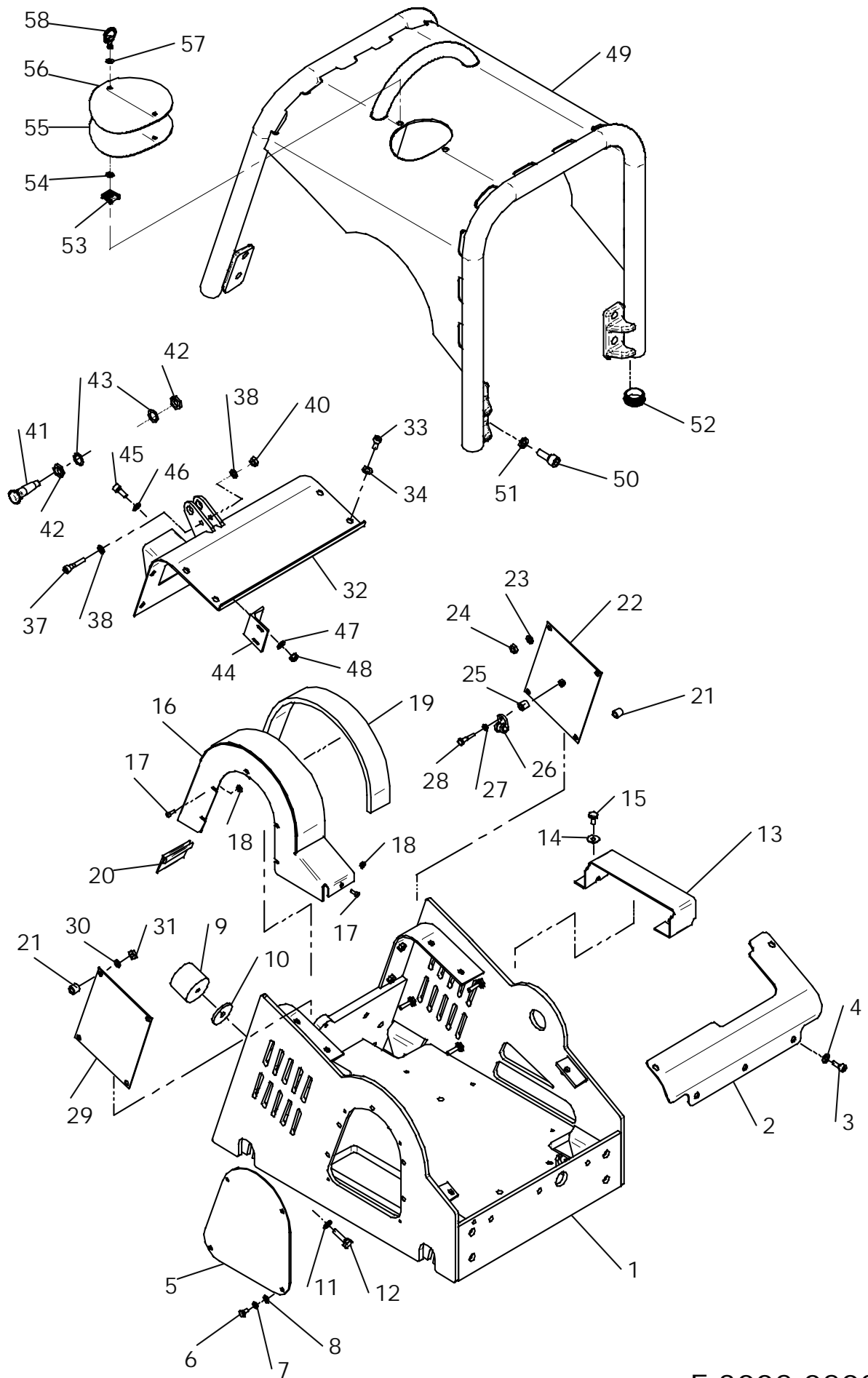

E 3002-0202

E 3003-1001

Position Ref.No. Repère Posizione Posicion	Menge Quantity Quantité Quantità Cantidad	Teile-Nr. Part-No. No. Référence Nr. d'Ordine No. Referenzia	Hinweis Hints Indications Indicazione Indicaciones	Position Ref. No. Repère Posizione Posicion	Menge Quantity Quantité Quantità Cantidad	Teile-Nr. Part-No. No. Référence Nr. d'Ordine No. Referenzia	Hinweis Hints Indications Indicazione Indicaciones
1	1	20001233		30	1	20007007	
2	2	25041065	DIN931-M12x100	31	1	25044003	DIN912-M6x20
3	1	25044066	DIN912-M12x90	32	1	25031002	DIN934-M6
4	1	20025158		33	1	25049034	DIN7349-6,4
5	1	25040079	DIN931-M12x110	34	1	20022001	Tensilock M6
6	3	25048004	DIN125-A13	35	1	10016365	
7	4	20029026		36	1	25033026	
8	4	25031005	DIN934-M12	37	1	20029001	VSK 10
9	2	25048004	DIN125-A13	38	1	25044017	DIN912-M10x65
10	1	25031005	DIN934-M12	39	1	25031024	DIN936-M10
11	1	10016368		40	2	25048010	DIN1440-11x25x3
12	4	20029011	VSKZ 8	41	1	25031004	DIN934-M10
13	4	25044006	DIN912-M8x25	42	1	10009916	
14	1	20002082		43	1	20025047	
15	1	25002175		44	1	20025060	
16	1	25049011	DIN7349-13x30x6	45	1	20025271	
17	1	20029004	VSK 12	46	1	20007077	
18	1	25040033	DIN931-M12x70	47	1	25048003	DIN125-A10,5
19	1	30047269		48	1	25038015	DIN933-M10x30
20	3	20029012	VSKZ 10				
21	3	25044041	DIN912-M10x20				
22	1	10022538					
23	3	20029012	VSKZ 10				
24	3	25044041	DIN912-M10x20				
25	1	20025590					
26	1	10022516					
27	4	20029020	SKB 6				
28	4	25044003	DIN912-M6x20				
29	2	20025485					

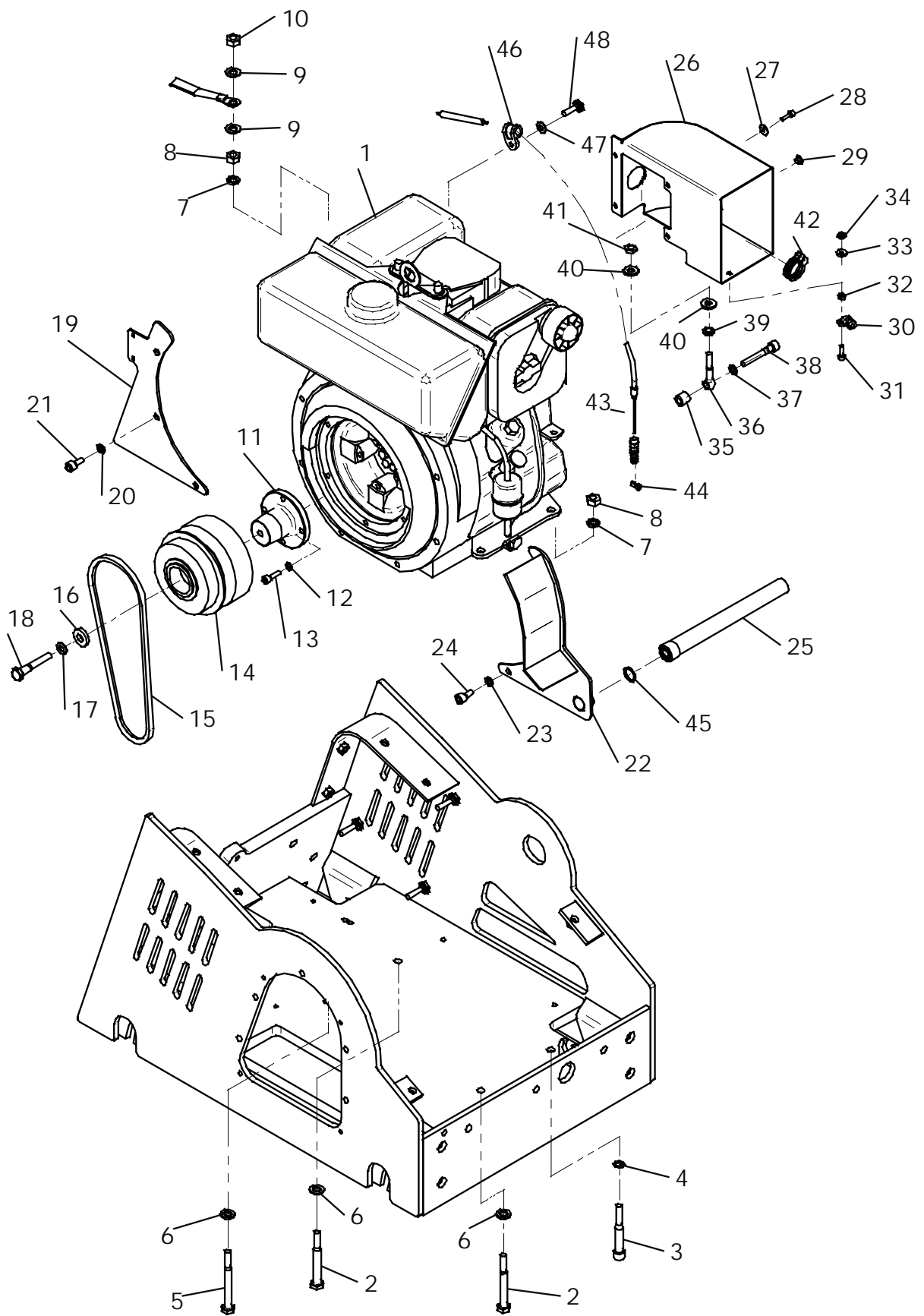

E 3003-1001

E 3004-0202

Position Ref.No. Repère Posizione Posicion	Menge Quantity Quantité Quantita Cantidad	Teile-Nr. Part-No. No. Référence Nr. d'Ordine No. Referenzia	Hinweis Hints Indications Indicazione Indicaciones	Position Ref. No. Repère Posizione Posicion	Menge Quantity Quantité Quantita Cantidad	Teile-Nr. Part-No. No. Référence Nr. d'Ordine No. Referenzia	Hinweis Hints Indications Indicazione Indicaciones
1	1	20002082					
2	2	20002268					
3	2	20002330					

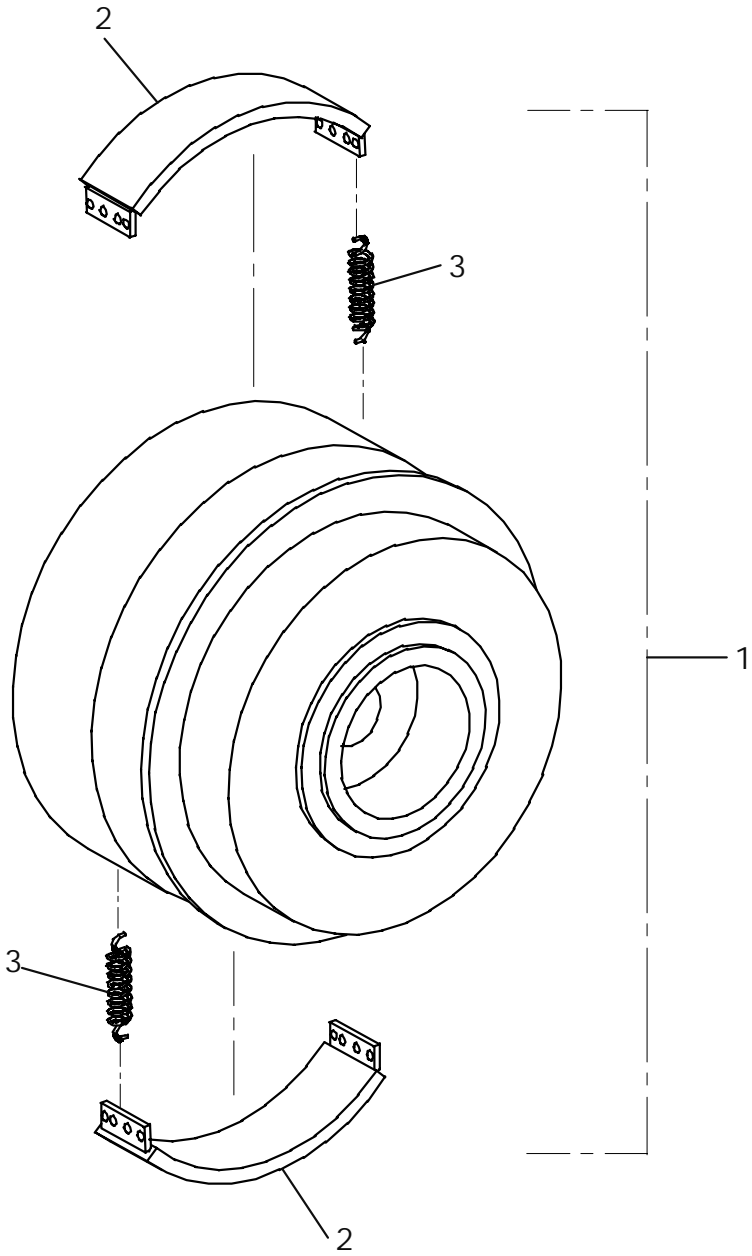

E 3004-0202

E 3005-0202

Position Ref.No. Repère Posizione Posicion	Menge Quantity Quantité Quantità Cantidad	Teile-Nr. Part-No. No. Référence Nr. d'Ordine No. Referenzia	Hinweis Hints Indications Indicazione Indicaciones	Position Ref. No. Repère Posizione Posicion	Menge Quantity Quantité Quantità Cantidad	Teile-Nr. Part-No. No. Référence Nr. d'Ordine No. Referenzia	Hinweis Hints Indications Indicazione Indicaciones
1	1	10022519		36	2	10022521	
2	1	10022520		37	2	20026468	
3	8	20029022	SKB 10	38	2	20029023	SKB 12
4	8	25038013	DIN933-M10x20	39	2	25038020	DIN933-M12x30
5	2	10016290		41	1	20025764	
6	4	25044055	DIN912-M8x50	42	1	20008069	
7	4	20029003	VSK 8	43	1	10016307	
8	4	25031003	DIN934-M8	44	1	20013282	
9	2	20004016		45	2	20013285	
10	2	10016291		46	1	10016305	
11	2	20029002	VSK 16	47	1	20013286	
12	2	25040066	DIN931-M16x55	48	1	10016303	
13	1	10016294		49	1	10016308	
14	2	20029029		50	4	20025122	
15	2	25044102	DIN912-M16x35	51	4	25044006	DIN912-M8x25
16	1	10016295		52	2	25047022	DIN7991-M6x12
17	2	20029029		53	1	20020562	
18	2	25044102	DIN912-M16x35	54	1	20016367	
19	4	20029003	VSK 8	55	1	20018080	
20	4	25040056	DIN931-M8x25	56	1	20018082	
21	1	20007089		57	1	20018081	
22	1	10016402		58	1	20018143	
23	1	25048002	DIN125-A8,4	59	2	20029007	VSK 6
24	1	25040004	DIN931-M8x55	60	2	25040067	DIN931-M6x30
25	1	20007089		61	2	20026492	
26	1	10015676		62	2	20026491	
27	1	20029003	VSK 8	63	1	10016100	
28	1	25040027	DIN931-M8x35				
29	1	10016309					
30	1	25008019					
31	1	25030018	DIN908-M26x1,5				
32	1	10016306					
33	2	20013284					
34	2	10016304					
35	2	20013283					

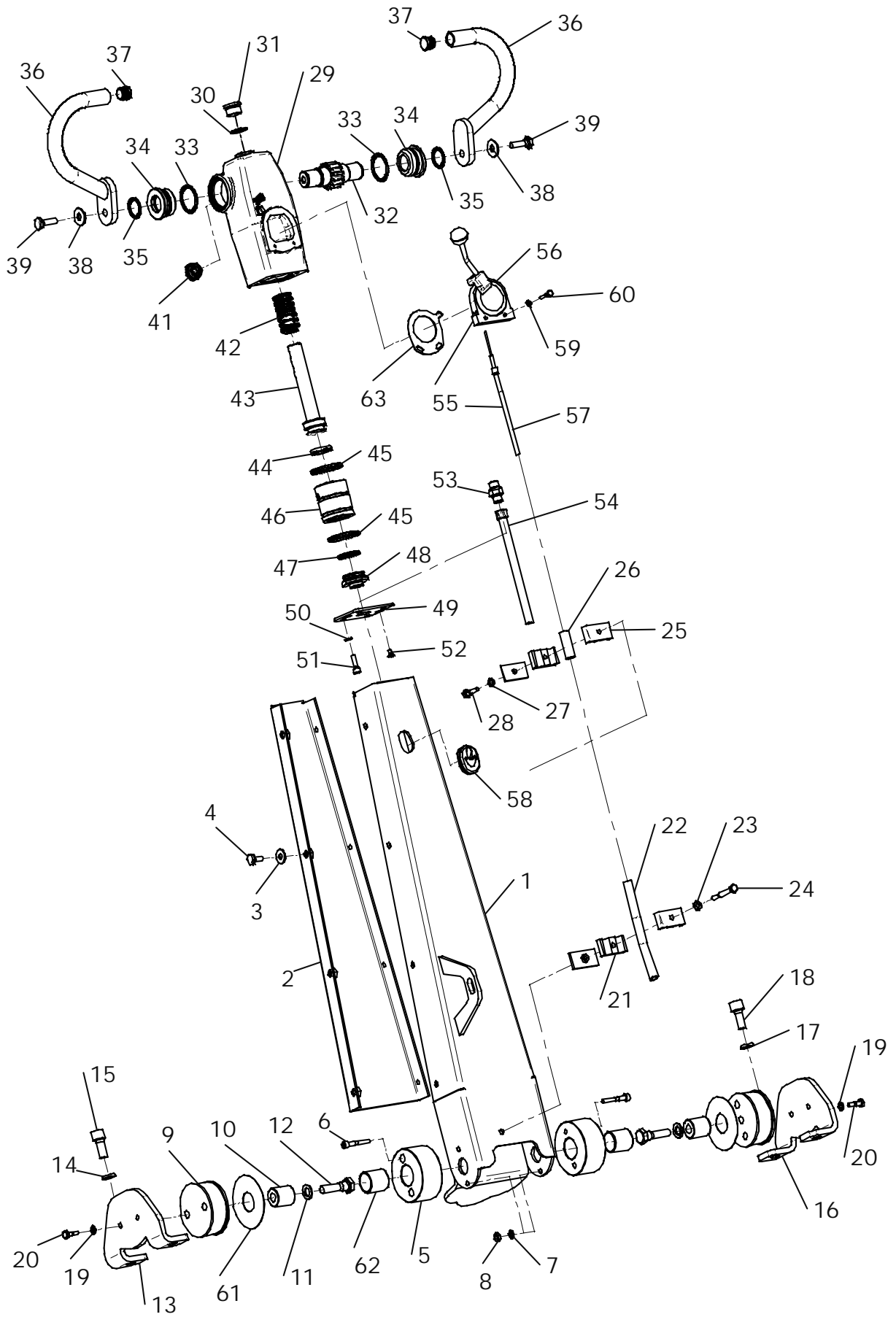

E 3005-0202

E 3006-0502

Position Ref.No. Repère Posizione Posicion	Menge Quantity Quantité Quantità Cantidad	Teile-Nr. Part-No. No. Référence Nr. d'Ordine No. Referenzia	Hinweis Hints Indications Indicazione Indicaciones	Position Ref. No. Repère Posizione Posicion	Menge Quantity Quantité Quantità Cantidad	Teile-Nr. Part-No. No. Référence Nr. d'Ordine No. Referenzia	Hinweis Hints Indications Indicazione Indicaciones
1	1	10003989					
2	2	25038007	DIN933-M8x20				
3	2	20029003	VSK 8				
4	1	20031502					
5	2	10015530					
6	1	10015675					
7	1	10001253					
8	1	10001416					
9	1	20025566					
10	1	10015828					
11	1	10015631					
12	2	25020028					
13	10	25031003	DIN934-M8				
14	4	20029003	VSK 8				
15	1	10001425					
16	2	25038003	DIN933-M6x20				
17	2	20029020	SKB 6				
18	1	10001424					
19	1	10001427					
20	1	20031541					
21	1	20031532					
22	2	25038038	DIN933-M5x16				
23	2	25048017	DIN125-A5,3				
24	2	25031023	DIN985-M5				

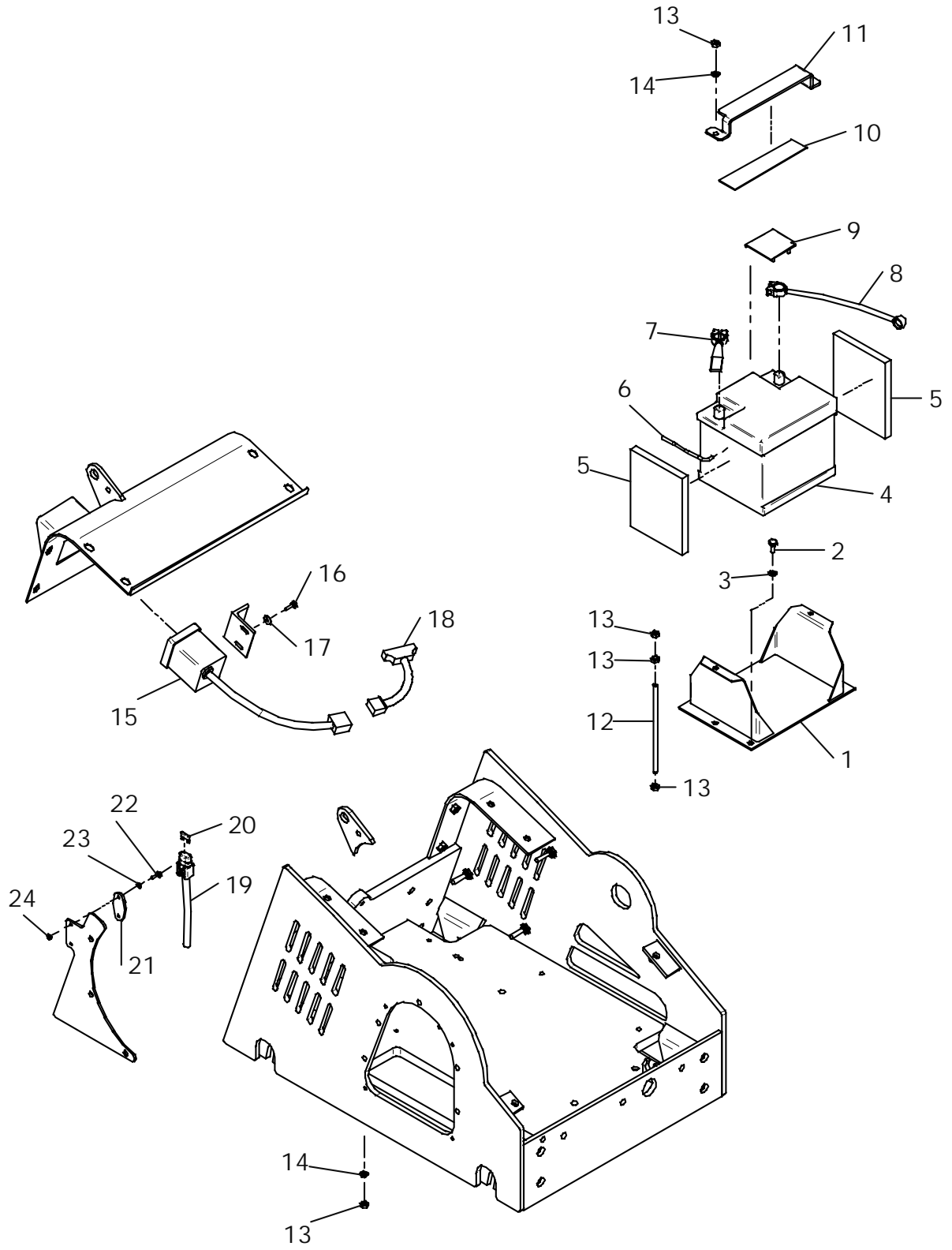

E 3007-0202

Position Ref.No. Repère Posizione Posicion	Menge Quantity Quantité Quantita Cantidad	Teile-Nr. Part-No. No. Référence Nr. d'Ordine No. Referenzia	Hinweis Hints Indications Indicazione Indicaciones	Position Ref. No. Repère Posizione Posicion	Menge Quantity Quantité Quantita Cantidad	Teile-Nr. Part-No. No. Référence Nr. d'Ordine No. Referenzia	Hinweis Hints Indications Indicazione Indicaciones
1	1	10016451					
2	2	10016452					
3	6	25038076	DIN933-M12x100				
4	6	20029004	VSK 12				
5	6	25031005	DIN934-M12				

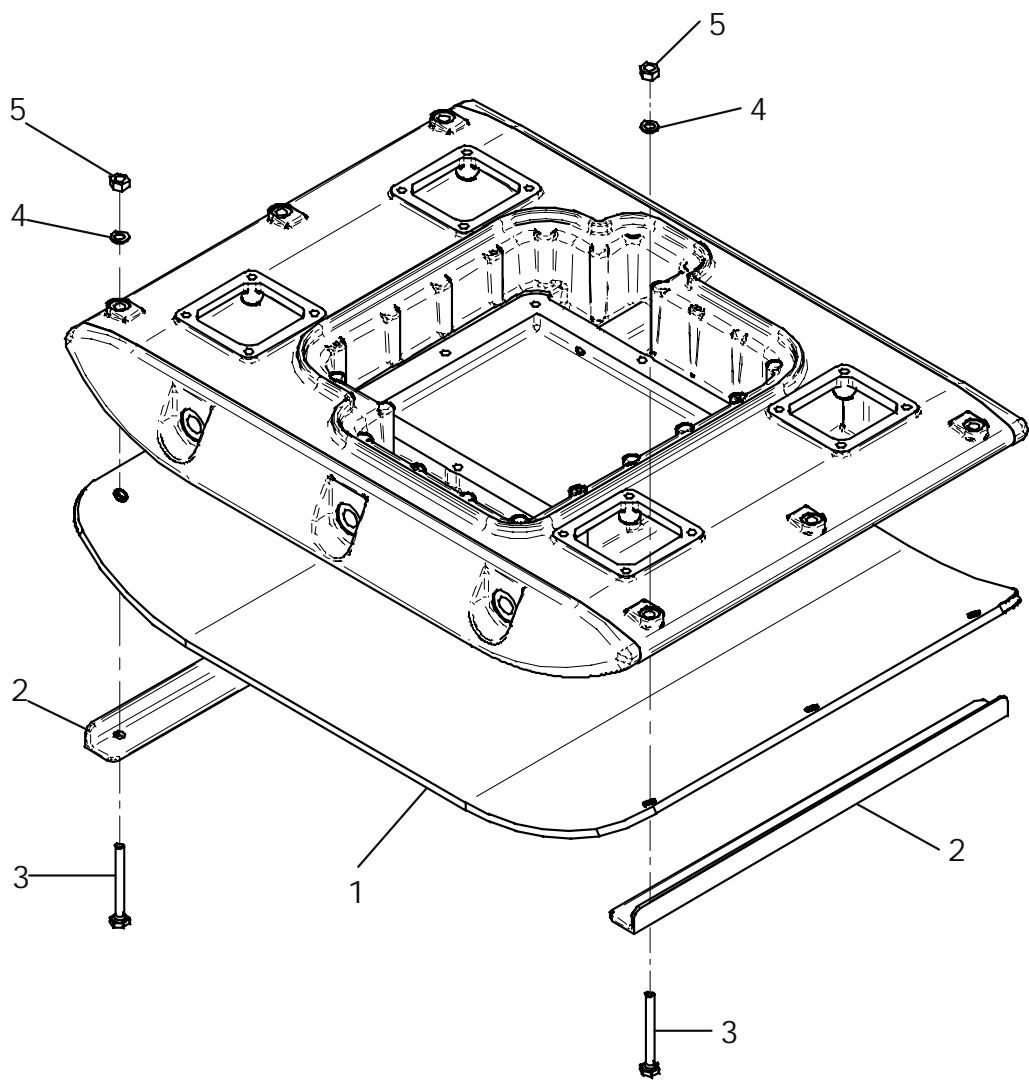

E 3007-0202

E 3041-0402

Position Ref.No. Repère Posizione Posicion	Menge Quantity Quantité Quantita Cantidad	Teile-Nr. Part-No. No. Référence Nr. d'Ordine No. Referenzia	Hinweis Hints Indications Indicazione Indicaciones	Position Ref. No. Repère Posizione Posicion	Menge Quantity Quantité Quantita Cantidad	Teile-Nr. Part-No. No. Référence Nr. d'Ordine No. Referenzia	Hinweis Hints Indications Indicazione Indicaciones
1	2	10016443					
2	6	20029009	VSK 20				
3	6	25038084	DIN933-M20x100				
4	1	10016699					
5	2	10016702					
6	6	25038076	DIN933-M12x100				
7	6	20029004	VSK 12				
8	6	25031005	DIN934-M12				

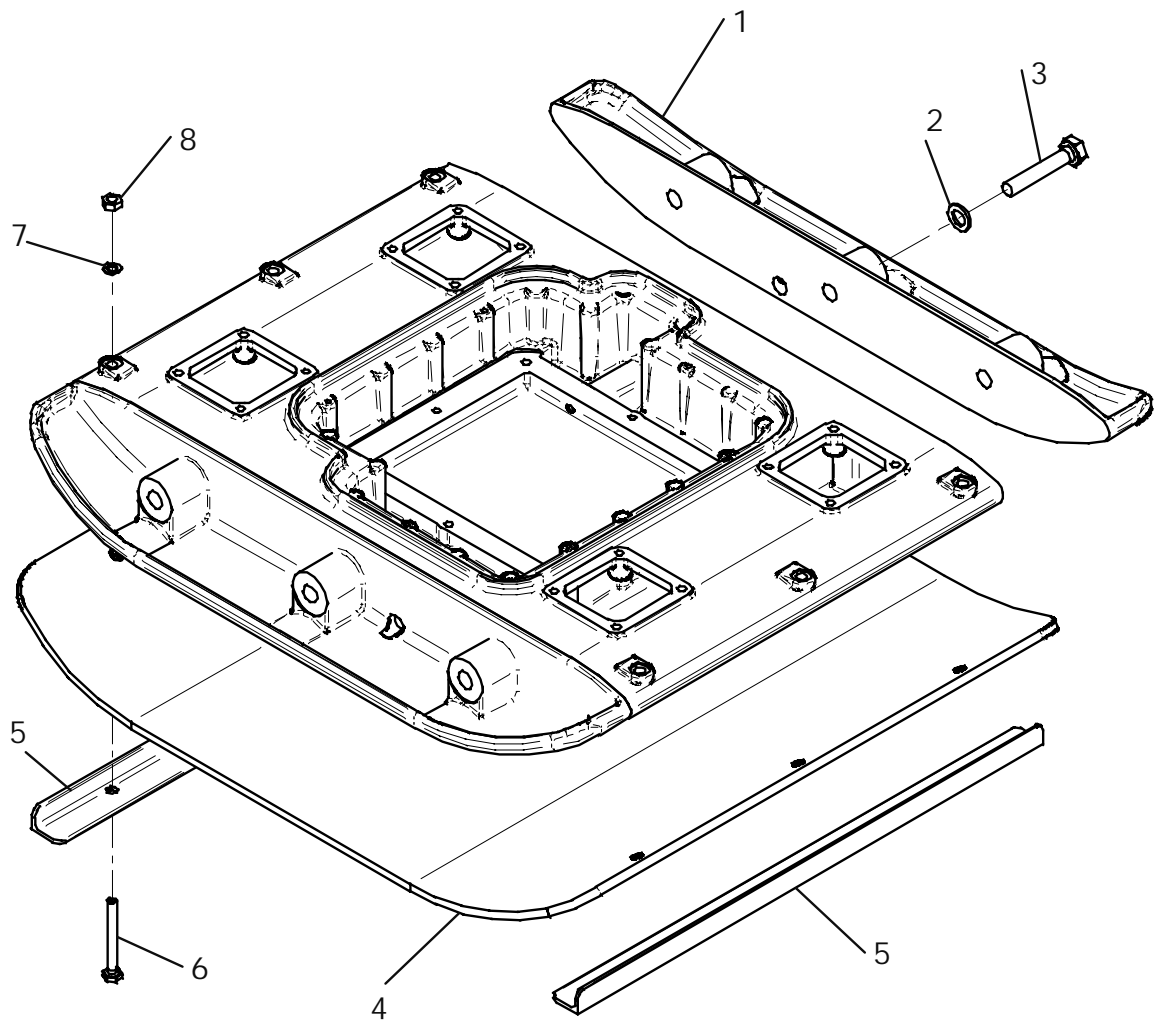

E 3041-0402

E 3042-0402

Position Ref.No. Repère Posizione Posicion	Menge Quantity Quantité Quantita Cantidad	Teile-Nr. Part-No. No. Référence Nr. d'Ordine No. Referenzia	Hinweis Hints Indications Indicazione Indicaciones	Position Ref. No. Repère Posizione Posicion	Menge Quantity Quantité Quantita Cantidad	Teile-Nr. Part-No. No. Référence Nr. d'Ordine No. Referenzia	Hinweis Hints Indications Indicazione Indicaciones
1	1	10006815					
2	2	10006816					
3	1	20005004					
4	1	20029003	VSK 8				
5	1	25031003	DIN934-M8				
6	2	25048002	DIN125-A8,4				
7	2	25038008	DIN933-M8x25				
8	2	20029003	VSK 8				
9	2	25031003	DIN934-M8				
10	1	20015034					
11	1	20015072					

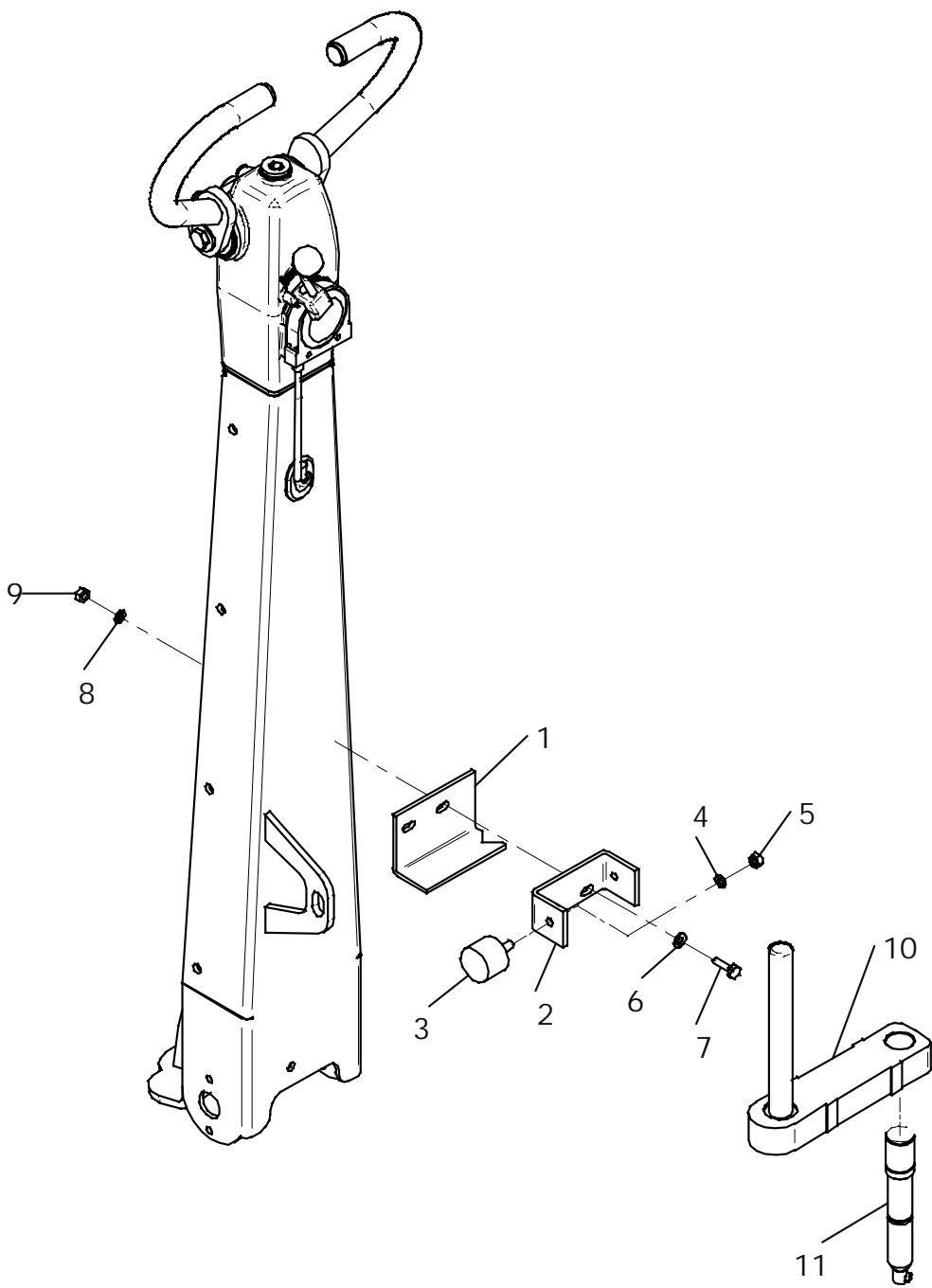

E 3042-0402

For problems, questions and further information refer to one of the following addresses:

in Germany and	WEBER Maschinenteknik GmbH Postfach 2153 57329 Bad Laasphe – Rückershausen	Telefon Telefax Telefax	02754 / 398-0 switchboard 02754 / 398101 02754 / 398102 - spare parts- directlinie
In Netherlands	WEBER Machinetechniek B.V. Graafschap Hornelaan 159 6001 AC Weert	Telefon Telefax	0495 / 530215 0495 / 541839
in France	WEBER Technologie S.a.r.l. 26, rue d'Arsonval 69680 Chassieu	Telefon Telefax	04.72.79.10.20 04.72.79.10.21
in Poland	WEBER Maschinenteknik SP. ZO.O. ul. Grodziska 7 05-830 Stara Wies / Nadarzyn	Telefon Telefax	22 / 739 70 – 80 22 / 739 70 – 81 22 / 739 70 - 82
in USA und Canada	WEBER Machine (USA), Inc. 40 Johnson Ave 112 Bangor, ME 04401	Telefon Telefax	207 / 947 / 4990 207 / 947 / 5452
in South - America	WEBER Maschinenteknik do Brasil Ltda. Rua Sete de Setembro, 275 93332-470 Novo Hamburgo-RS	Telefon Telefax	0055 - 51 - 587 3044 0055 - 51 - 587 2271

