



ERSATZTEILLISTE

SPARE PARTS LIST

**LISTE DES PIECES
DE RECHANGE**

LISTINO RICAMBI

LISTA DE RECAMBIOS

**WYKAZ CZESCI
ZAMIENNYCH**



CR 8

**0116402,
0116701-0116708**

Ab Masch.-Nr. 8004769



Weber Maschinenteknik GmbH
Postfach 2153, 57329 Bad Laasphe-Rückershausen
Telefon 02754 / 398-0
Telefax (02754) 398-101 (Zentrale) u. 398-102 (Ersatzteile)

EG - KONFORMITÄTSERKLÄRUNG

EC DECLARATION OF CONFORMITY/ DECLARATION DE CONFORMITE CE
DICHIAZIONE CE DI CONFORMITA / DECLARACION CE DE CONFORMIDAD
EG-VERKLARING VAN OVEREENSTEMMING / EF-OVERENSSTEMMELSESERKAERING
DECLARACAO CE DE CONFORMIDADE / EG-FÖRSÄKRAN OM ÖVERENSSTÄMMELSE
DEKLARACJA ZGODNOŚCI

im Sinne der EG-Maschinenrichtlinie 98/37/EG
und der EG Richtlinie 2000/14/EG – Geräuschemissionen

- I **Hersteller/ Make / Marque / Marca / Marca / Producent / Merk / Marca /**
Tillverkare / Producent **Weber Maschinentechnik GmbH**
Im Boden 5-8,10
57334 Bad Laasphe
- II **Art / Category / Catégorie / Categoría Tipo / Kategori /**
Soort / Categoría / kategori / Typ **Vibrationsplatte**
- III **Typ / Type / Type / Tipo / Codice / Type / Type / Tipo / Typ /**
CR 8 , CR 8 CCD ,
CR 8 MSM
- IV **Nennleistung / Nominal-performance / La puissance nominale / Prestazione nominale /**
Potencia nominal / Nominaal vermogen / Nominel ydelse / Potência nominal / Nominell
effect / Moc **P = 11 kW**
- V **gemessener Schalleistungspegel / measured sound power level / niveau de**
puissance acoustique mesure / livello di potenza sonora rilevato / nivel de potencia
acústica medido / gemeten geluidsvermogensniveau / målt lydeffektniveau / Nivel de
potência sonora midido / uppmätt ljudeffektnivå / Mierzony poziom dźwięku **LWA = 108 dB (A)**
- VI **garantierter Schalleistungspegel / guaranteed sound power level / niveau de**
puissance acoustique garanti / livello di potenza sonora garantito / nivel de potencia
acustica garantizado / gewaarborgd geluidsvermogensniveau / garanteret lydeffektniveau /
Nivel sonoro garantido / garanterad ljudeffektnivå / Natężenie hałas **LWA = 109 dB (A)**
- VII **beteiligte Zertifizierungsstelle / notified body involved / de l'organisme notifié/**
dell'organismo notificato che l'ha effettuata / dirección del organismo notificado que haya
intervenido / betrokken aangemelde instantie / pågældende bemyndigede organ /
organismo notificado involucrado / berörda anmälda organets namn / Jednostka
certyfikująca **RWTÜV**
Postfach 103161
D-45032 Essen
- VIII **Konformitäts-Bewertungsverfahren / Conformity assessment procedure followed /**
la procédure appliquée pour l'évaluation de la conformité et / procedura di valutazione
della conformità / procedimiento de evaluación de la conformidad / gevolgde
overeenstemmingsbeoordelingsprocedure / den fulgte
overensstemmelssesvurderingsprocedure / procedimento de avaliacao de conformidade
/vilket förfarande för bedömning av överensstämmelse / Przebieg kontroli **interne Fertigungskontrolle**
nach Anhang VI
EG Richtlinie 2000/14/EG

ist in Übereinstimmung mit folgenden Richtlinien hergestellt worden /has been produced in accordance
with following standards / est produit conforme aux dispositions des directives europeenes ci-apres / ha sido
fabricado en conformidad con las siguientes normas / è stato fabbricato in conformità alle seguenti norme / er blevet
fremstillet i overensstemmelse med følgende retningslinier / in overensstemming met de volgende voorschriften
gefabricceerd is / é fabricado conforme as seguintes normas / har tillverkats i överensstämmelse med följande riktlinjer
/ Zgodność z obowiązującymi przepisami

98/37/EG Maschinenrichtlinie des europäischen Parlamentes und des Rates vom 22.
Juni 1998
2000/14/EG EG-Richtlinie Geräuschemissionen vom 8. Mai 2000
2005/88/EG EG-Richtlinie vom 14. Dez. 2005 zur Änderung der Richtlinie 2000/14/EG
EN 500 Teil 1 Bewegliche Straßenbaumaschinen – Sicherheit
Gemeinsame Anforderungen
EN 500 Teil 4 Bewegliche Straßenbaumaschinen – Sicherheit
Besondere Anforderungen an Verdichtungsmaschinen

Bescheinigung bitte sorgfältig aufbewahren / File certificate carefully / Conserver certificat soigneusement /
Conserver certificado cuidadosamente / Pregasi conservare accuratamente certificato / Beviset bedes opbevares
omhyggeligt / Verklaring a.u.b. zorgvuldig bevare / Conserver o certificado com cuidado / Beviset skall om sorgsfullt
bevaras // Deklarację zgodności proszę zachować

Bad Laasphe – Rückershausen, den **02.01.2009**

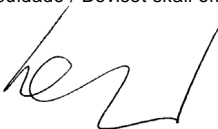
W. Weber, Geschäftsführer

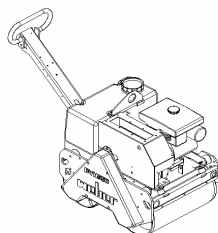

weber_{mt}

WEBER Maschinentechnik GmbH
Im Boden 5-8, 10 – D-57334 Bad Laasphe
Postfach 2153 – D-57329 Bad Laasphe
Telefon: 02754/398-0 – Fax 02754/398-101
E-mail: Verkauf@webermt.de
Internet: <http://www.webermt.de>

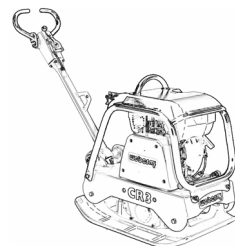

EG - KONFORMITÄTSERKLÄRUNG

EC DECLARATION OF CONFORMITY / DECLARACION DE CONFORMITE CE
DICHIAZIONE CE DI CONFORMITA / DECLARACION CE DE CONFORMIDAD
EG-VERKLARING VAN OVEREENSTEMMING / EF-OVERENSSTEMMELSESERKAERING
DECLARACAO CE DE CONFORMIDADE / EG-FÖRSÄKRAN OM ÖVERENSSTÄMMELSE
DEKLARACJA ZGODNOŚCI

im Sinne der EG-Maschinenrichtlinie 98/37/EG
und der EG Richtlinie 2000/14/EG – Geräuschemissionen

- | | | |
|------|---|--|
| I | Hersteller/ Make / Marque / Marca / Marca / Producent / Merk / Marca /
Tillverkare / Producent | Weber Maschinenteknik GmbH
Im Boden 5-8,10
57334 Bad Laasphe |
| II | Art / Category / Catégorie / Categoria Tipo / Kategori /
Soort / Categoria / kategori / Typ | Vibrationsplatte |
| III | Typ / Type / Type / Tipo / Codice / Type / Type / Tipo / Typ / | CR 8 Hd CCD |
| IV | Nennleistung / Nominal-performance / La puissance nominale / Prestazione nominale /
Potencia nominal / Nominaal vermogen / Nominel ydelse / Potência nominal / Nominell
effect / Moc | P = 9,6 kW |
| V | gemessener Schalleistungspegel / measured sound power level / niveau de
puissance acoustique mesure / livello di potenza sonora rilevato / nivel de potencia
acústica medido / gemeten geluidsvermogensniveau / mált lydeffektniveau / Nivel de
potência sonora midido / uppmått ljudeffektnivå / Mierzony poziom dźwięku | LWA = 108 dB (A) |
| VI | garantierter Schalleistungspegel / guaranteed sound power level / niveau de
puissance acoustique garanti / livello di potenza sonora garantito / nivel de potencia
acústica garantizado / gewaarborgd geluidsvermogensniveau / garanteret lydeffektniveau /
Nivel sonoro garantido / garanterad ljudeffektnivå / Natężenie hałasu | LWA = 109 dB (A) |
| VII | beteiligte Zertifizierungsstelle / notified body involved / de l'organisme notifié/
dell'organismo notificato che l'ha effettuata / dirección del organismo notificado que haya
intervenido / betrokken aangemelde instantie / pagældende bemyndigede organ /
organismo notificado involucrado / berörda anmälda organets namn / Jednostka
certyfikująca | RWTÜV
Postfach 103161
D-45032 Essen |
| VIII | Konformitäts-Bewertungsverfahren / Conformity assessment procedure followed /
la procédure appliquée pour l'évaluation de la conformité et / procedura di valutazione
della conformità / procedimiento de evaluación de la conformidad / gevolgde
overeenstemmingsbeoordelingsprocedure / den fulgte
overensstemmelsesvurderingsprocedure / procedimento de avaliacao de conformidade
/ Vilket förfarande för bedömning av överensstämmelse / Przebieg kontroli | interne Fertigungskontrolle
nach Anhang VI
EG Richtlinie 2000/14/EG |

ist in Übereinstimmung mit folgenden Richtlinien hergestellt worden /has been produced in accordance
with following standards / est produit conforme aux dispositions des directives europeenes ci-apres / ha sido
fabricado en conformidad con las siguientes normas / é stato fabbricato in conformità alle sequenti norme / er blevet
fremstillet i overensstemmelse med følgende retningslinjer / in overeenstemming met de volgende voorschriften
gefabricceerd is / é fabricado conforme as seguintes normas / har tillverkats i överensstämmelse med följande riktlinjer
/ Zgodność z obowiązującymi przepisami

98/37/EG	Maschinenrichtlinie des europäischen Parlamentes und des Rates vom 22. Juni 1998
2000/14/EG	EG-Richtlinie Geräuschemissionen vom 8. Mai 2000
2005/88/EG	EG-Richtlinie vom 14. Dez. 2005 zur Änderung der Richtlinie 2000/14/EG
EN 500 Teil 1	Bewegliche Straßenbaumaschinen – Sicherheit Gemeinsame Anforderungen
EN 500 Teil 4	Bewegliche Straßenbaumaschinen – Sicherheit Besondere Anforderungen an Verdichtungsmaschinen

Bescheinigung bitte sorgfältig aufbewahren / File certificate carefully / Conserver certificat soigneusement /
Conservar certificado cuidadosamente / Pregasi conservare accuratamente certificato / Beviset bedes opbevares
omhyggeligt / Verklaring a.u.b. zorgvuldig beware / Conservar o certificado com cuidado / Beviset skall om sorgsfullt
bevaras // Deklarację zgodności proszę zachować

Bad Laasphe – Rückershausen, den **02.01.2009**

W. Weber, Geschäftsführer

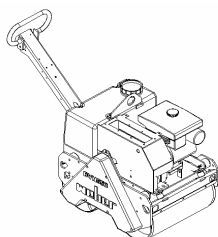

weberm?

WEBER Maschinenteknik GmbH
Im Boden 5-8, 10 – D-57334 Bad Laasphe
Postfach 2153 – D-57329 Bad Laasphe
Telefon: 02754/398-0 – Fax 02754/398-101
E-mail: Verkauf@webermt.de
Internet: <http://www.webermt.de>



BITTE, NOTIEREN SIE SERIENNUMMER UND MOTORNUMMER IHRER MASCHINE:

PLEASE WRITE DOWN SERIALNUMBERS OF MACHINE AND ENGINE:

NOTEZ SVP LE NUMERO DE SERIE ET LE NUMERO DU MOTEUR DE VOTRE MACHINE:

SI PREGA DI ANNOTARE SEMPRE I NUMERI DI SERIE SIA DELLA VS. MACCHINA CHE DEL MOTORE:

MAQUINA: ROGAMOS ANOTEN EL NUMERO DE SERIE Y NUMERO DE MOTOR DE SU MAQUINA:

MASCHINE
MACHINE
MACCHINA
MAQUINA

#

MOTOR
ENGINE
MOTEUR
MOTORE

#

ZUR VERMEIDUNG VON FEHLLIEFERUNGEN UND VERZÖGERUNGEN SIND BEI DER BESTELLUNG VON ERSATZTEILEN FOLGENDE ANGABEN UNBEDINGT ERFORDERLICH:

- MASCHINENTYP
- SERIENNUMMER DER MASCHINE
- SERIENNUMMER DES MOTORS (BEI MOTORTEILEN)
- TEILENUMMER
- BESTELLMENGE

TO AVOID ERRORS IN DELIVERY PLEASE STATE THESE PARTICULARS WHEN ORDERING:

- TYPE OF MACHINE
- SERIAL NO. OF MACHINE
- SERIAL NO. OF ENGINE (ON ENGINE PARTS)
- PART-NO.
- QUANTITY REQUIRED

AFIN D'EVITER DES ERREURS DE COMMANDE ET DES RETARDS DE LIVRAISON IL EST NECESSAIRE D'INDIQUER LES CARACTERISTIQUES SUIVANTES:

- TYPE DE MACHINE
- LE NUMERO DE SERIE DE LA MACHINE
- LE NUMERO DE SERIE DU MOTEUR
- LE NUMERO D'IDENTITE DE LA PIECE
- LA QUANTITE SOUHAITEE

ONDE EVITARE DISGUIDI E RITARDI NELLE CONSEGNE DIE RICAMBI SI PREGA DI INDICARE SEMPRE:

- TIPO DELLA MACCHINA
- NUMERO DI SERIE DELLA MACCHINA
- NUMERO DI SERIE DEL MOTORE (SE SI RICHIEDONO PEZZI DEL MOTORE)
- NUMERO D'ORDINE DIE SINGOLI RICAMBI
- QUANTITA

A FI DE EVITAR ERRORES DE ENTREGA, ROGAMOS INDIQUEN LOS SIGUIENTES DATOS CUANDO PASE PEDIDOS DE RECAMBIO:

- MODELO DE MAQUINA
- NO. DE SERIE DE LA MAQUINA
- NO. DE SERIE DEL MOTOR (EN PIEZAS PARA MOTOR)
- REFERENCIA DEL RECAMBIO
- CANTIDAD PEDIDA

E 3000-0806

Position Ref.No. Repère Posizione Posicion	Menge Quantity Quantité Quantità Cantidad	Teile-Nr. Part-No. No. Référence Nr. d'Ordine No. Referenzia	Hinweis Hints Indications Indicazione Indicaciones	Position Ref. No. Repère Posizione Posicion	Menge Quantity Quantité Quantità Cantidad	Teile-Nr. Part-No. No. Référence Nr. d'Ordine No. Referenzia	Hinweis Hints Indications Indicazione Indicaciones
1	1	10016160					
2	8	20026485					
3	1	25030002	DIN908-M14x1,5				
4	2	10016161					
5	6	20029009	VSK 20				
6	6	25038027	DIN933-M20x50				
7	2	11000288					
8	2	11000289					
9	12	20025158					
10	12	25038021	DIN933-M12x35				
11	4	20004012					
12	8	25049019	DIN7349-17x40x6				
13	8	20029002	VSK 16				
14	4	25031006	DIN934-M16				
15	4	25025009	DIN1587-16				
16	4	10016367					
17	4	10001423					
18	4	20025158					
19	4	20005018					
20	1	20013289					
21	1	20013288					
22	1	20013287					
23	6	20029011	VSKZ 8				
24	6	25044007	DIN912-M8x30				
25	1	10001482					
26	8	20029026					
27	6	25045041	DIN912-M12x140-12.9				
28	2	25045042	DIN912-M12x170-12.9				

Hatz

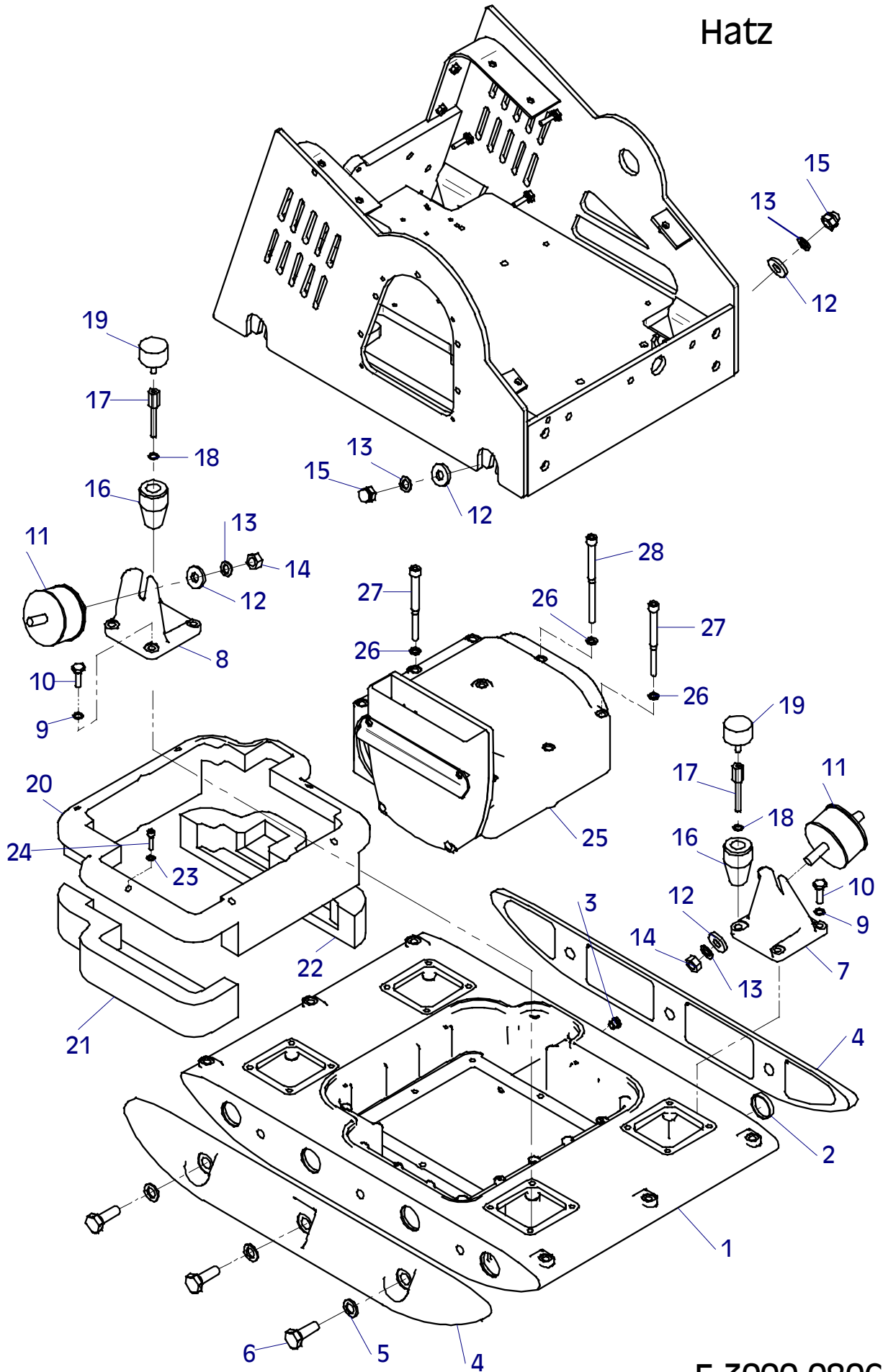

E 3000-0806

E 3177-0806

Position Ref.No. Repère Posizione Posicion	Menge Quantity Quantité Cantidad	Teile-Nr. Part-No. No. Référence Nr. d'Ordine No. Referenzia	Hinweis Hints Indications Indicazione Indicaciones	Position Ref. No. Repère Posizione Posicion	Menge Quantity Quantité Cantidad	Teile-Nr. Part-No. No. Référence Nr. d'Ordine No. Referenzia	Hinweis Hints Indications Indicazione Indicaciones
1	1	10016160		30	2	20025158	
2	8	20026485		31	2	25044047	DIN912-M12x50
3	1	25030002	DIN908-M14x1,5	32	2	10017304	
4	2	10016161		33	2	10017300	
5	6	20029009	VSK 20	34	2	20026576	
6	6	25038027	DIN933-M20x50				
7	2	11000288					
8	2	11000289					
9	12	20025158					
10	12	25038021	DIN933-M12x35				
11	4	20004012					
12	8	25049019	DIN7349-17x40x6				
13	8	20029002	VSK 16				
14	4	25031006	DIN934-M16				
15	4	25025009	DIN1587-16				
16	2	10016367					
17	2	10001423					
18	2	20025158					
19	2	20005018					
20	1	20013289					
21	1	20013288					
22	1	20013287					
23	6	20029011	VSKZ 8				
24	6	25044007	DIN912-M8x30				
25	1	10001482	CR 8 CCD				
25	1	10001465	CR 8 Hd CCD				
26	8	20029026					
27	6	25045041	DIN912-M12x140-12.9				
28	2	25045042	DIN912-M12x170-12.9				
29	2	10017360					

Hatz-CCD / MSM
Honda-CCD

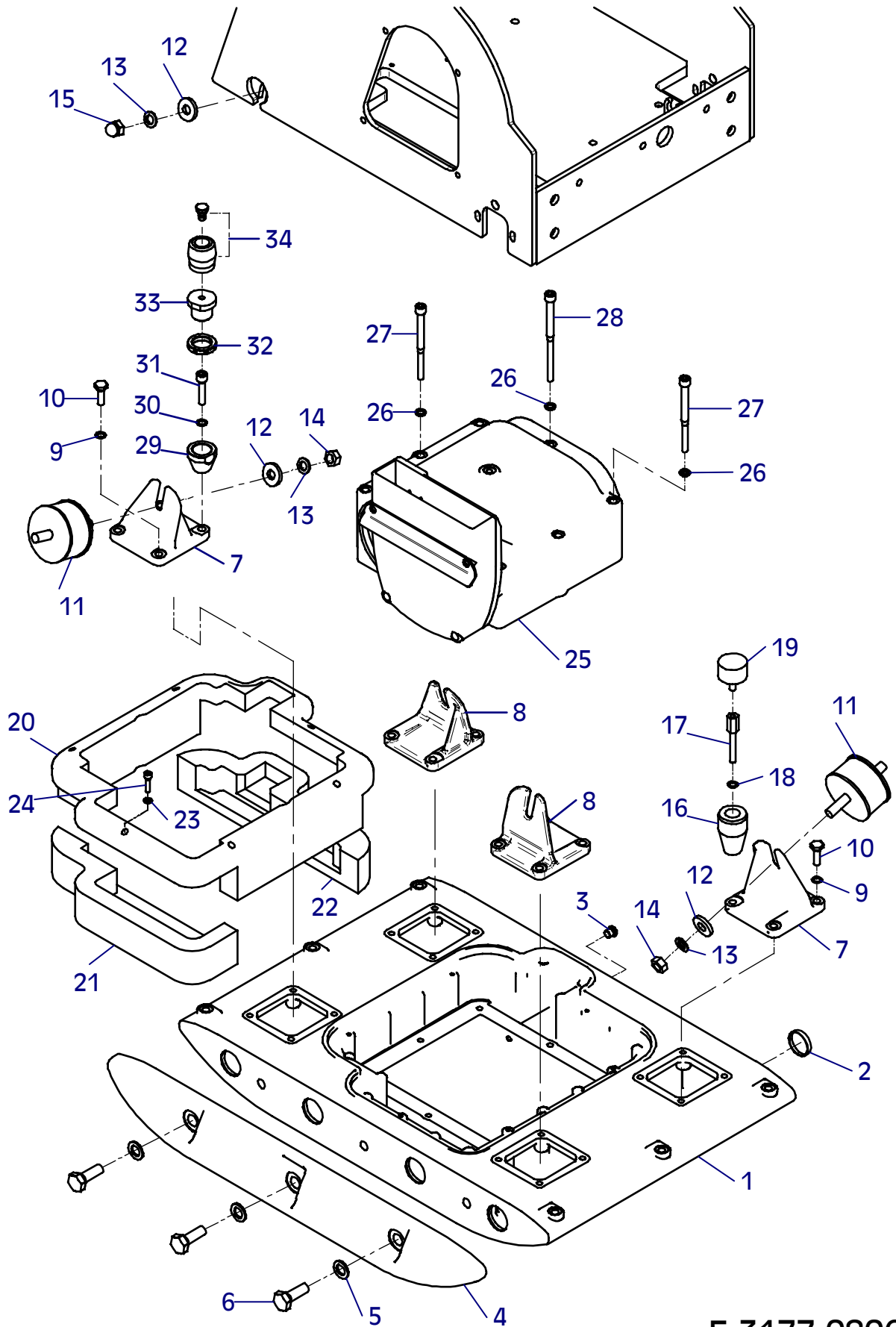

E 3177-0806

E 3001-0205

Position Ref.No. Repère Posizione Posicion	Menge Quantity Quantité Quantita Cantidad	Teile-Nr. Part-No. No. Référence Nr. d'Ordine No. Referenzia	Hinweis Hints Indications Indicazione Indicaciones	Position Ref. No. Repère Posizione Posicion	Menge Quantity Quantité Quantita Cantidad	Teile-Nr. Part-No. No. Référence Nr. d'Ordine No. Referenzia	Hinweis Hints Indications Indicazione Indicaciones
1	1	10016164		29	1	10017035	Honda
2	1	25038042	DIN933-M12x16	30	1	10016388	
3	1	25008011	DIN7603-12x18x1,5	31	1	10007370	
4	1	10016165		32	1	20029001	VSK 10
5	2	25044010	DIN912-M8x65	33	1	10016382	
6	2	20029011	VSKZ 8	34	2	25001701	
7	2	10016167		35	1	10016826	
8	8	25044005	DIN912-M8x20	36	2	25025157	
9	8	20029011	VSKZ 8	37	2	25045035	DIN912-M12x50-10.9
10	2	20013290		38	1	10016386	
11	1	10016166		39	2	25001702	
12	4	25044005	DIN912-M8x20	40	1	10016171	
13	4	20029011	VSKZ 8	41	1	10016383	
14	1	25017201		42	1	10016385	
15	1	20013290		43	1	25029015	
16	1	10016168		44	1	25028004	DIN915-M10x25
17	4	25044005	DIN912-M8x20	45	1	25035018	DIN472-I32
18	4	20029011	VSKZ 8	46	1	25001703	
19	1	25030016	DIN910-M10x1	47	1	25034025	DIN471-A15x1
20	1	25008012	DIN7603-10x16x1	48	1	10016387	
21	1	20013290		49	1	20013275	
22	1	10016379		50	1	25030001	DIN908-M10x1
23	2	25001701		51	1	20020562	
24	1	10016170		52	0	25026027	
25	1	25015076		53	0	25026028	
26	2	10016827		54	0	25026029	
27	2	25025157		55	1	20013305	
28	2	25045035	DIN912-M12x50-10.9	56	1	10017386	
29	1	10017338	Hatz	57	2	25047065	DIN7991-M8x80

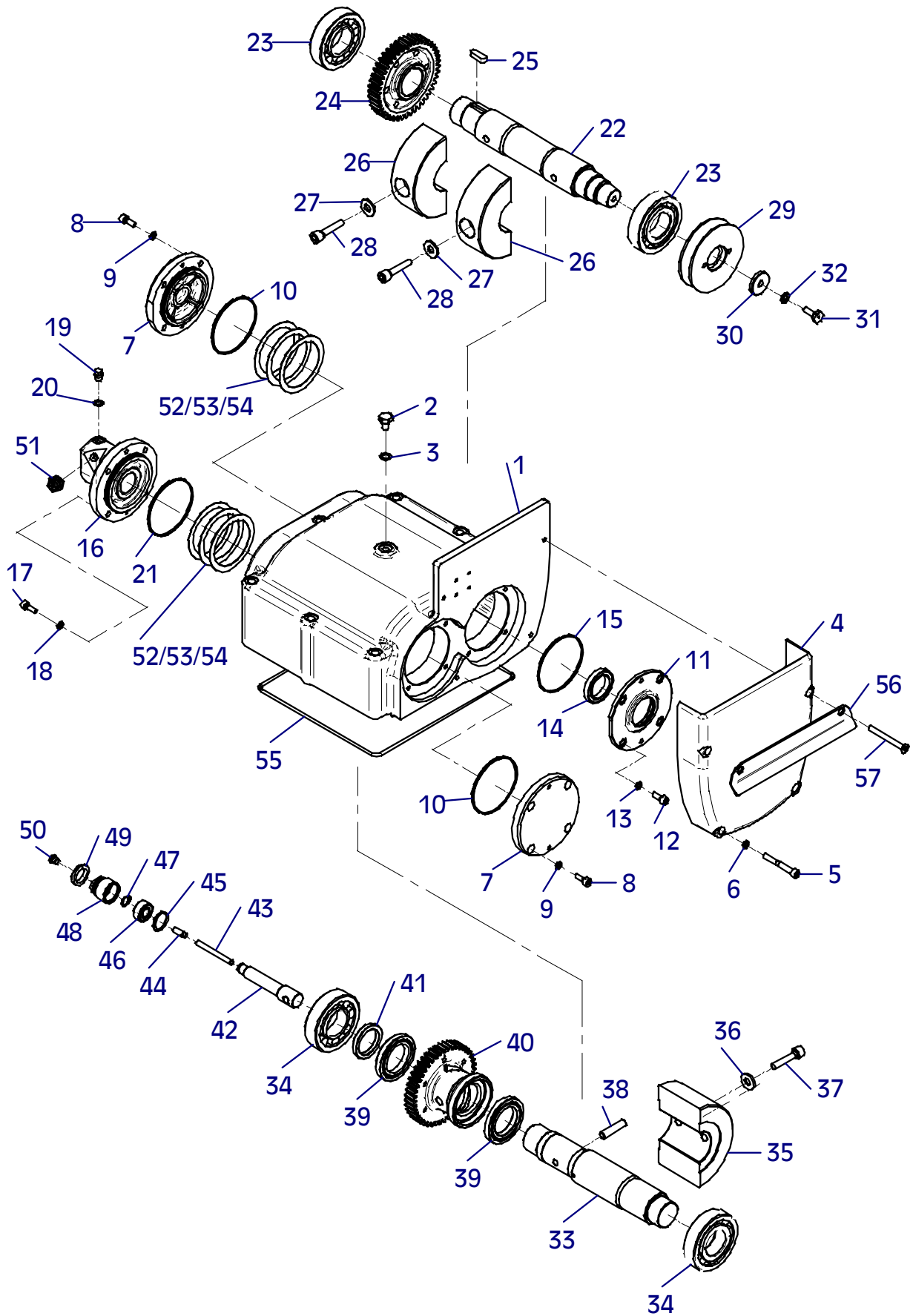

E 3001-0205

E 3193-0707

Position Ref.No. Repère Posizione Posicion	Menge Quantity Quantité Quantita Cantidad	Teile-Nr. Part-No. No. Référence Nr. d'Ordine No. Referenzia	Hinweis Hints Indications Indicazione Indicaciones	Position Ref. No. Repère Posizione Posicion	Menge Quantity Quantité Quantita Cantidad	Teile-Nr. Part-No. No. Référence Nr. d'Ordine No. Referenzia	Hinweis Hints Indications Indicazione Indicaciones
1	1	11000550		31	8	20029029	
2	1	10016301		32	4	20026565	
3	4	25038008	DIN933-M8x25	33	1	10017377	
4	4	20029003	VSK 8	34	2	25033029	ISO7380-M6x16-10.9
5	4	25048002	DIN125-A8,4	35	2	25048001	DIN125-A6,4
6	2	10017392		36	2	20022001	Tensilock M6
7	2	11000043		37	1	40030706	
8	4	25038014	DIN933-M10x25	38	2	20029020	SKB 6
9	4	20029033	SKM 10	39	2	25033038	DIN1587-M6
10	1	10017374		40	1	11000030	
11	5	25038014	DIN933-M10x25	41	1	20005001	
12	5	20029033	SKM 10	42	1	25031012	DIN985-M6
13	1	20025590		43	1	21000004	DIN71803-M6
14	1	11000433		44	1	25031012	DIN985-M6
15	5	25038014	DIN933-M10x25	45	1	10017337	
16	5	20029033	SKM 10	46	2	21000031	
17	3	25049013	DIN440-R11,5	47	2	11000148	
18	1	20026544		48	1	20026481	
19	1	25044063	DIN912-M8x35	49	2	25025191	DIN80705-M20x1,5
20	1	20026545		50	2	20025019	
21	1	11000484		51	1	20022002	Tensilock M8
22	4	25047020	DIN7991-M6x16	52	2	25048001	DIN125-A6,4
23	4	20029007	VSK 6	53	2	25040022	DIN931-M16x70
24	4	25031002	DIN934-M6	54	2	25031017	DIN985-M16
25	1	10017320		55	1	10015839	
26	2	25033030	ISO7380-M6x20-10.9	56	1	25044037	DIN912-M10x55
27	2	25049033	DIN9021-6,4/18x1,6	57	1	25048003	DIN125-A10,5
28	2	25031012	DIN985-M6	58	1	20029001	VSK 10
29	1	11000164		59	1	25031004	DIN934-M10
30	8	25044045	DIN912-M16x40-10.9				

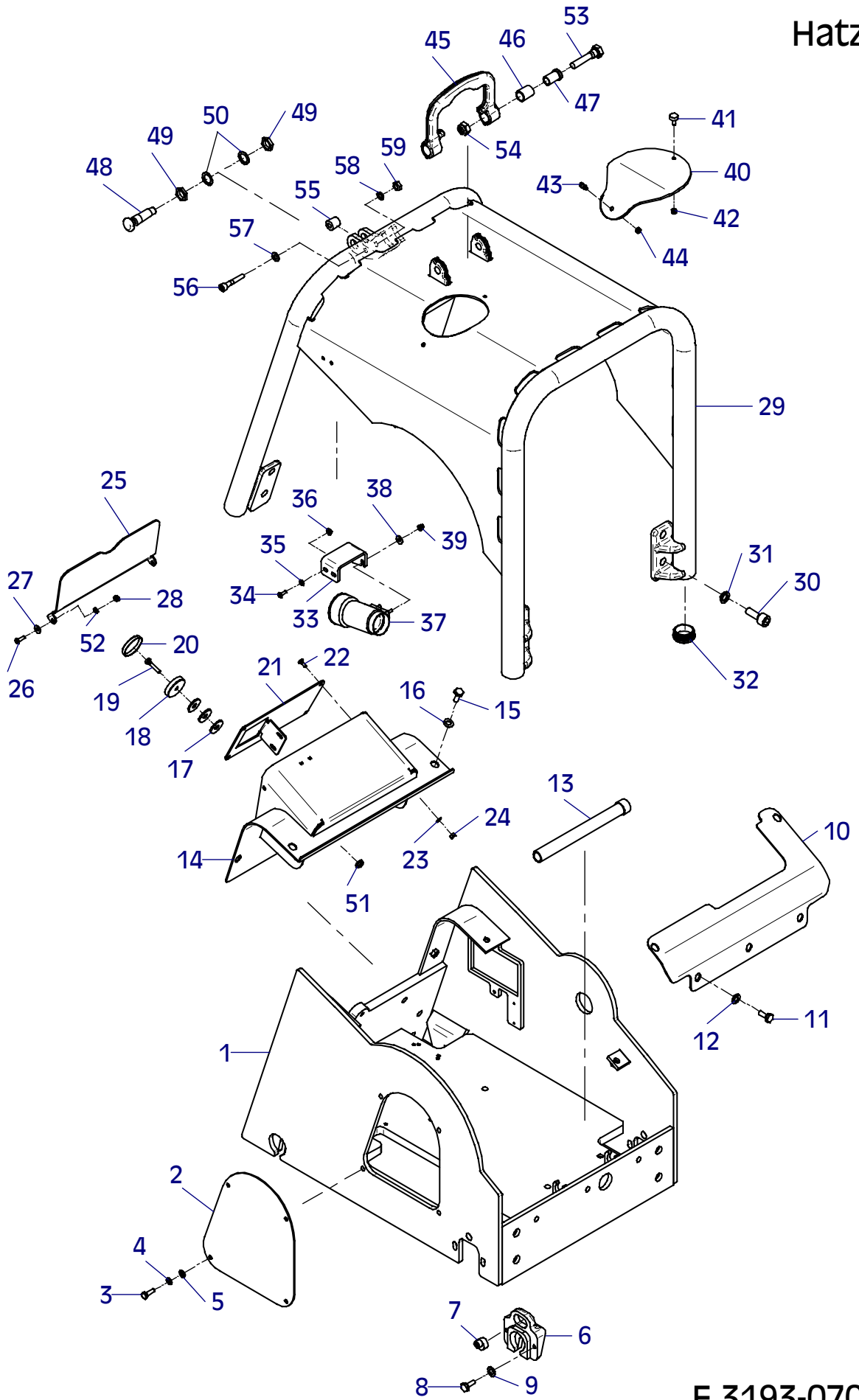

E 3194-0707

Position Ref.No. Repère Posizione Posicion	Menge Quantity Quantité Cantidad	Teile-Nr. Part-No. No. Référence Nr. d'Ordine No. Referenzia	Hinweis Hints Indications Indicazione Indicaciones	Position Ref. No. Repère Posizione Posicion	Menge Quantity Quantité Cantidad	Teile-Nr. Part-No. No. Référence Nr. d'Ordine No. Referenzia	Hinweis Hints Indications Indicazione Indicaciones
1	1	11000550		36	2	20022001	Tensilock M6
2	1	10016301		37	1	40030706	
3	4	25038008	DIN933-M8x25	38	2	20029020	SKB 6
4	4	20029003	VSK 8	39	2	25033038	DIN1587-M6
5	4	25048002	DIN125-A8,4	40	1	11000030	
6	2	10017392		41	1	20005001	
7	2	11000043		42	1	25031012	DIN985-M6
8	4	25038014	DIN933-M10x25	43	1	21000004	DIN71803-M6
9	4	20029033	SKM 10	44	1	25031012	DIN985-M6
10	1	10017374		45	1	10017337	
11	5	25038014	DIN933-M10x25	46	2	21000031	
12	5	20029033	SKM 10	47	2	11000148	
13	1	20025590		48	1	20026481	
14	1	11000433		49	2	25025191	DIN80705-M20x1,5
15	5	25038014	DIN933-M10x25	50	2	20025019	
16	5	20029033	SKM 10	51	1	20022002	Tensilock M8
17	3	25049013	DIN440-R11,5	52	2	25048001	DIN125-A6,4
18	1	20026544		53	2	25040022	DIN931-M16x70
19	1	25044063	DIN912-M8x35	54	2	25031017	DIN985-M16
20	1	20026545		55	1	10015839	
21	1	11000436		56	1	25044037	DIN912-M10x55
22	4	25047020	DIN7991-M6x16	57	1	25048003	DIN125-A10,5
23	4	20029007	VSK 6	58	1	20029001	VSK 10
24	4	25031002	DIN934-M6	59	1	25031004	DIN934-M10
25	1	10017320		60	2	10017359	
26	2	25033030	ISO7380-M6x20-10.9	61	8	25038006	DIN933-M8x16
27	2	25049033	DIN9021-6,4/18x1,6	62	8	20029031	SKM 8
28	2	25031012	DIN985-M6				
29	1	11000164					
30	8	25044045	DIN912-M16x40-10.9				
31	8	20029029					
32	4	20026565					
33	1	10017377					
34	2	25033029	ISO7380-M6x16-10.9				
35	2	25048001	DIN125-A6,4				

Hatz-CCD

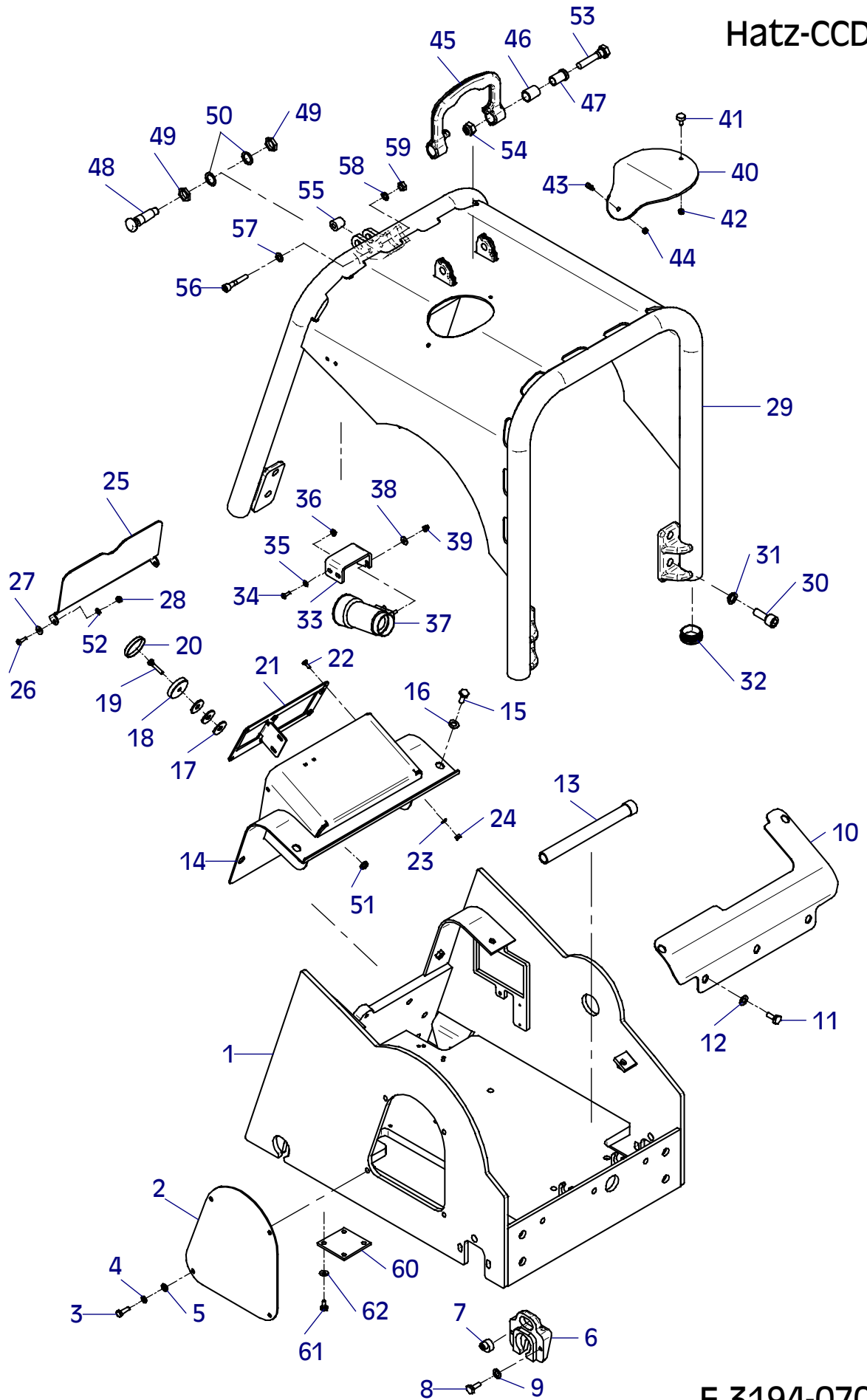

E 3194-0707

E 3282-0807

Position Ref.No. Repère Posizione Posicion	Menge Quantity Quantité Cantidad	Teile-Nr. Part-No. No. Référence Nr. d'Ordine No. Referenzia	Hinweis Hints Indications Indicazione Indicaciones	Position Ref. No. Repère Posizione Posicion	Menge Quantity Quantité Cantidad	Teile-Nr. Part-No. No. Référence Nr. d'Ordine No. Referenzia	Hinweis Hints Indications Indicazione Indicaciones
1	1	11000550		36	2	20022001	Tensilock M6
2	1	10016301		37	1	40030706	
3	4	25038008	DIN933-M8x25	38	2	20029020	SKB 6
4	4	20029003	VSK 8	39	2	25033038	DIN1587-M6
5	4	25048002	DIN125-A8,4	40	1	11000030	
6	2	10017392		41	1	20005001	
7	2	11000043		42	1	25031012	DIN985-M6
8	4	25038014	DIN933-M10x25	43	1	21000004	DIN71803-M6
9	4	20029033	SKM 10	44	1	25031012	DIN985-M6
10	1	10017374		45	1	10017337	
11	5	25038014	DIN933-M10x25	46	2	21000031	
12	5	20029033	SKM 10	47	2	11000148	
13	1	20025590		48	1	20026481	
14	1	11000433		49	2	25025191	DIN80705-M20x1,5
15	5	25038014	DIN933-M10x25	50	2	20025019	
16	5	20029033	SKM 10	51			
17	3	25049013	DIN440-R11,5	52	2	25048001	DIN125-A6,4
18	1	20026544		53	2	25040022	DIN931-M16x70
19	1	25044063	DIN912-M8x35	54	2	25031017	DIN985-M16
20	1	20026545		55	1	10015839	
21	1	20022002	Tensilock M8	56	1	25044037	DIN912-M10x55
22	2	10017359		57	1	25048003	DIN125-A10,5
23	8	25038006	DIN933-M8x16	58	1	20029001	VSK 10
24	8	20029031	SKM 8	59	1	25031004	DIN934-M10
25	1	10017320					
26	2	25033030	ISO7380-M6x20-10.9				
27	2	25049033	DIN9021-6,4/18x1,6				
28	2	25031012	DIN985-M6				
29	1	11000164					
30	8	25044045	DIN912-M16x40-10.9				
31	8	20029029					
32	4	20026565					
33	1	10017377					
34	2	25033029	ISO7380-M6x16-10.9				
35	2	25048001	DIN125-A6,4				

Hatz-MSM

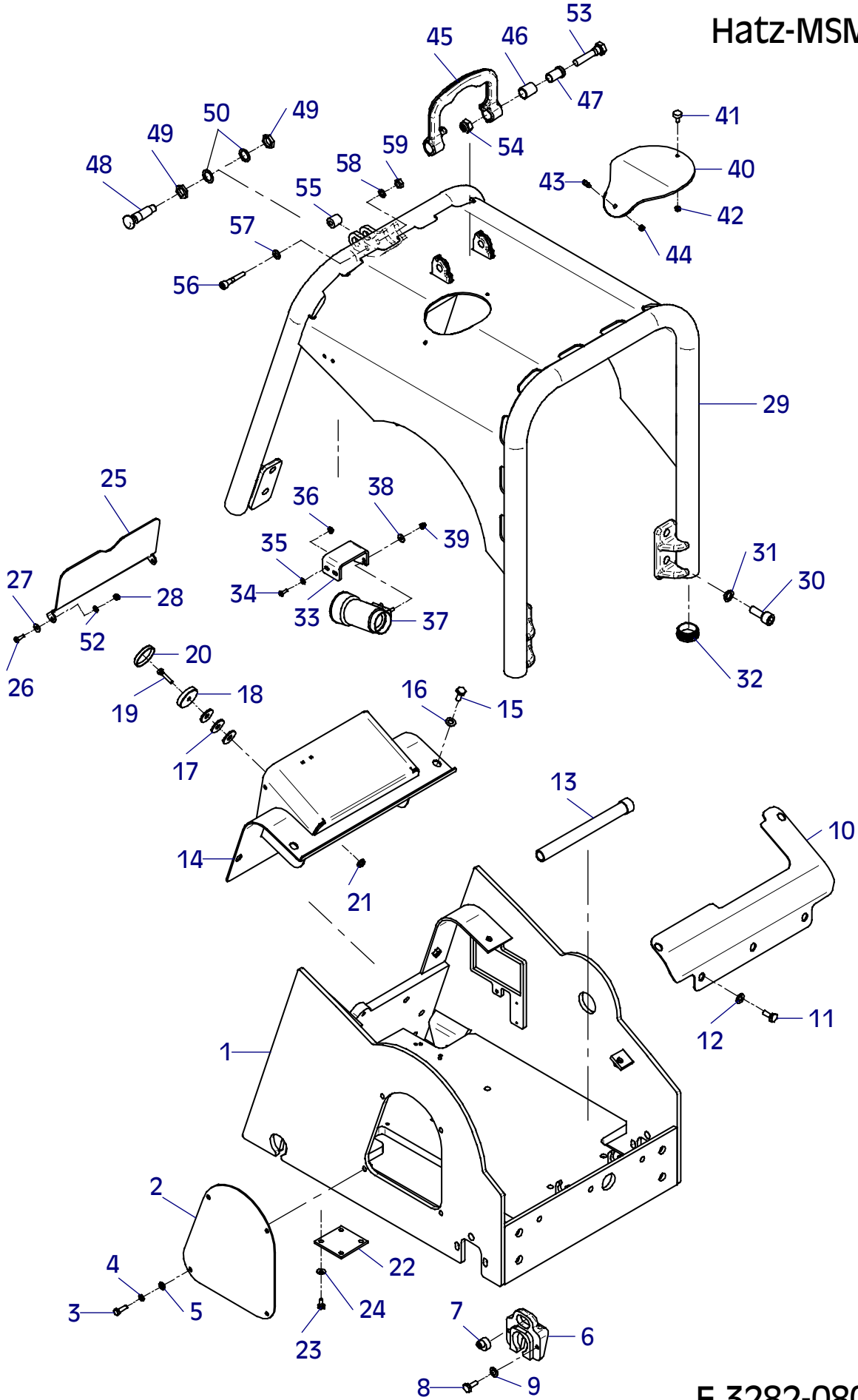

E 3282-0807

E 3195-1108

Position Ref.No. Repère Posizione Posicion	Menge Quantity Quantité Quantita Cantidad	Teile-Nr. Part-No. No. Référence Nr. d'Ordine No. Referenzia	Hinweis Hints Indications Indicazione Indicaciones	Position Ref. No. Repère Posizione Posicion	Menge Quantity Quantité Quantita Cantidad	Teile-Nr. Part-No. No. Référence Nr. d'Ordine No. Referenzia	Hinweis Hints Indications Indicazione Indicaciones
1	1	20001249		32	1	25044065	DIN912-M6x25
1	1	21000061	EPA	33	2	25049034	DIN7349-6,4
1	1	21000311	MSM	34	1	20022001	Tensilock M6
2	3	10017393		35	1	11000047	
3	3	25040079	DIN931-M12x110	36	4	25044002	DIN912-M6x16
4	1	25044067	DIN912-M12x100	37	4	20029007	VSK 6
5	4	20025158		38	4	25048001	DIN125-A6,4
7	1	11000624		39	2	20025485	
8	4	20029026		40	1	11000041	
9	4	25031005	DIN934-M12	41	1	11000040	
12	1	10016368		42	4	25038007	DIN933-M8x20
13	4	25044006	DIN912-M8x25	43	4	20029021	SKB 8
14	4	20029011	VSKZ 8	44	1	20007228	
15	1	21000388		45	2	11000036	
16	1	25002180		46	1	20026556	
17	1	25040033	DIN931-M12x70	47	1	25040001	DIN931-M6x60
18	1	20029004	VSK 12	48	2	25049034	DIN7349-6,4
19	1	25049011	DIN7349-13x30x6	49	1	20007007	
20	1	11000002		50	1	20022001	Tensilock M6
21	8	25044041	DIN912-M10x20	52	1	21000314	DIN913-M10x60
22	8	20029012	VSKZ 10	53	1	20007001	
23	1	20026578	0,97 m	54	1	25048003	DIN125-A10,5
24	2	20026578	0,105 m	55	1	25031004	DIN934-M10
25	2	20007007		56	1	20025047	
26	2	25044003	DIN912-M6x20	57	1	20025359	
27	2	25049034	DIN7349-6,4	58	1	40030707	
28	1	25031002	DIN934-M6	59	4	20007233	
29	1	20029007	VSK 6	60	1	10017354	
30	1	21000001		61	1	10017357	
31	1	20007232		62	2	41000414	

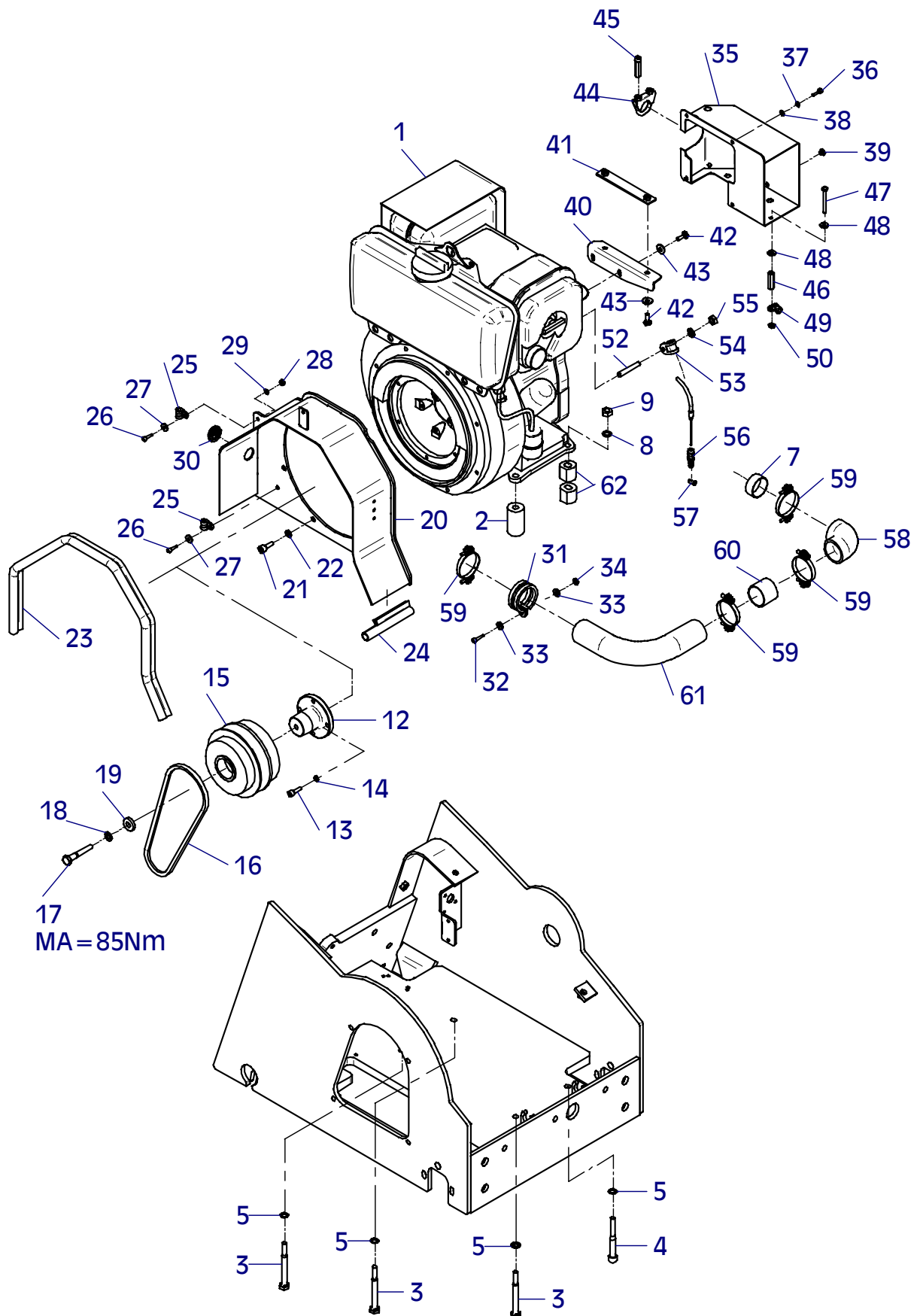

E 3317-1108

Position Ref.No. Repère Posizione Posicion	Menge Quantity Quantité Quantita Cantidad	Teile-Nr. Part-No. No. Référence Nr. d'Ordine No. Referenzia	Hinweis Hints Indications Indicazione Indicaciones	Position Ref. No. Repère Posizione Posicion	Menge Quantity Quantité Quantita Cantidad	Teile-Nr. Part-No. No. Référence Nr. d'Ordine No. Referenzia	Hinweis Hints Indications Indicazione Indicaciones
1	1	21000388					
2	2	20002268					
3	2	20002330					
4	2	21000117					
5	3	21000473					

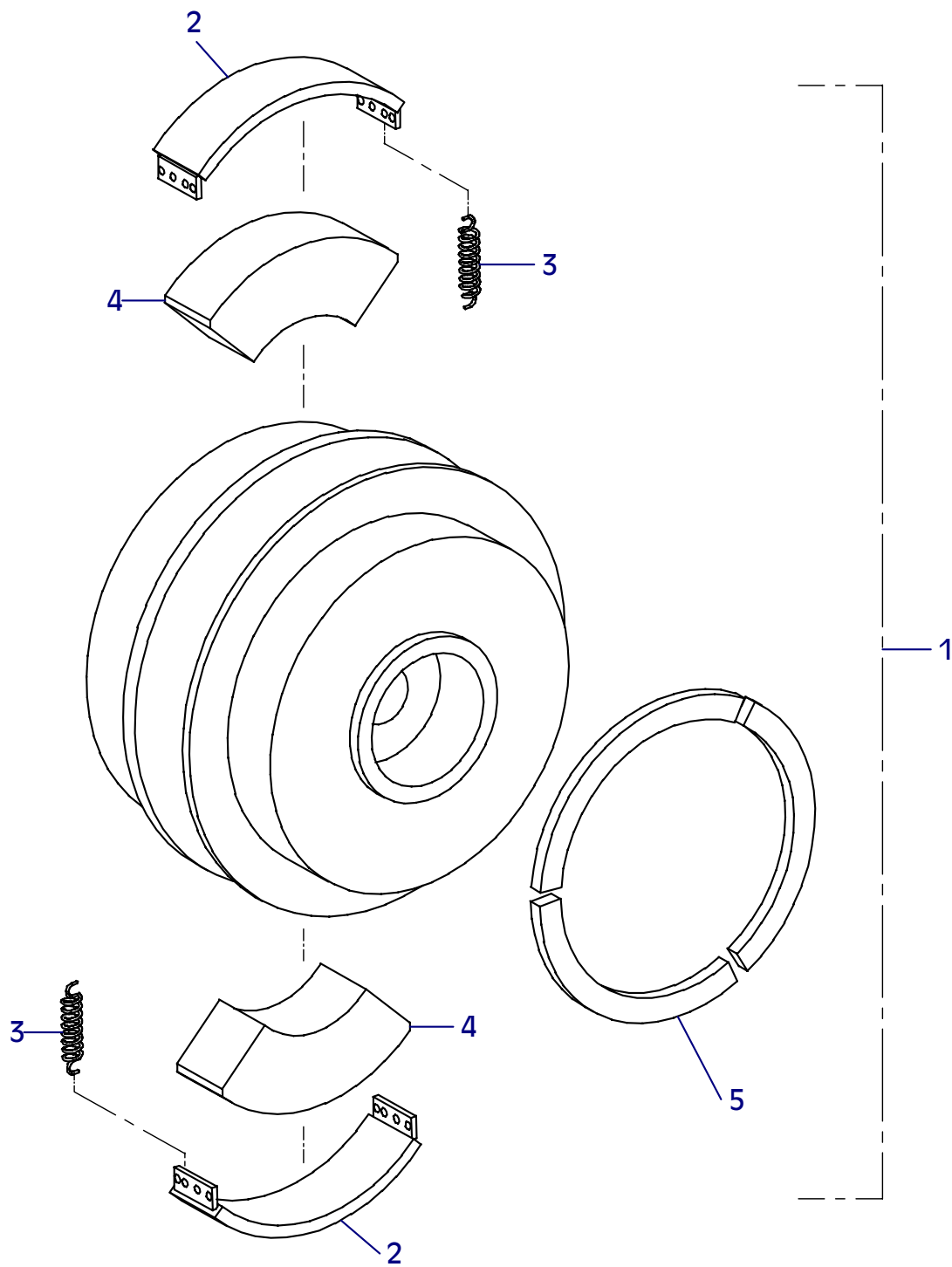

E 3317-1108

E 3197-0807

Position Ref.No. Repère Posizione Posicion	Menge Quantity Quantité Quantita Cantidad	Teile-Nr. Part-No. No. Référence Nr. d'Ordine No. Referenzia	Hinweis Hints Indications Indicazione Indicaciones	Position Ref. No. Repère Posizione Posicion	Menge Quantity Quantité Quantita Cantidad	Teile-Nr. Part-No. No. Référence Nr. d'Ordine No. Referenzia	Hinweis Hints Indications Indicazione Indicaciones
1	1	10003989					
2	2	25038007	DIN933-M8x20				
3	2	20029003	VSK 8				
4	1	20031502					
5	2	10017185					
6	2	10015530					
7	1	20016289	0,4 m				
8	1	10001406					
9	1	10001416					
10	1	20025566					
11	1	30025028	0,19 m				
12	1	10015631					
13	2	25020028	DIN976-M8x200				
14	8	25031003	DIN934-M8				
15	2	20029003	VSK 8				
16	1	10001469					
17	2	25038002	DIN933-M6x16				
18	2	20029020	SKB 6				
19	1	10001476					
20	1	10001427					
21	1	20031541					
22	1	20031532					
23	2	25038035	DIN933-M5x12				
24	2	25048017	DIN125-A5,3				
25	1	20007062					
26	1	25044119	DIN912-M5x10				
27	1	25048017	DIN125-A5,3				
28	1	21000353					

Hatz

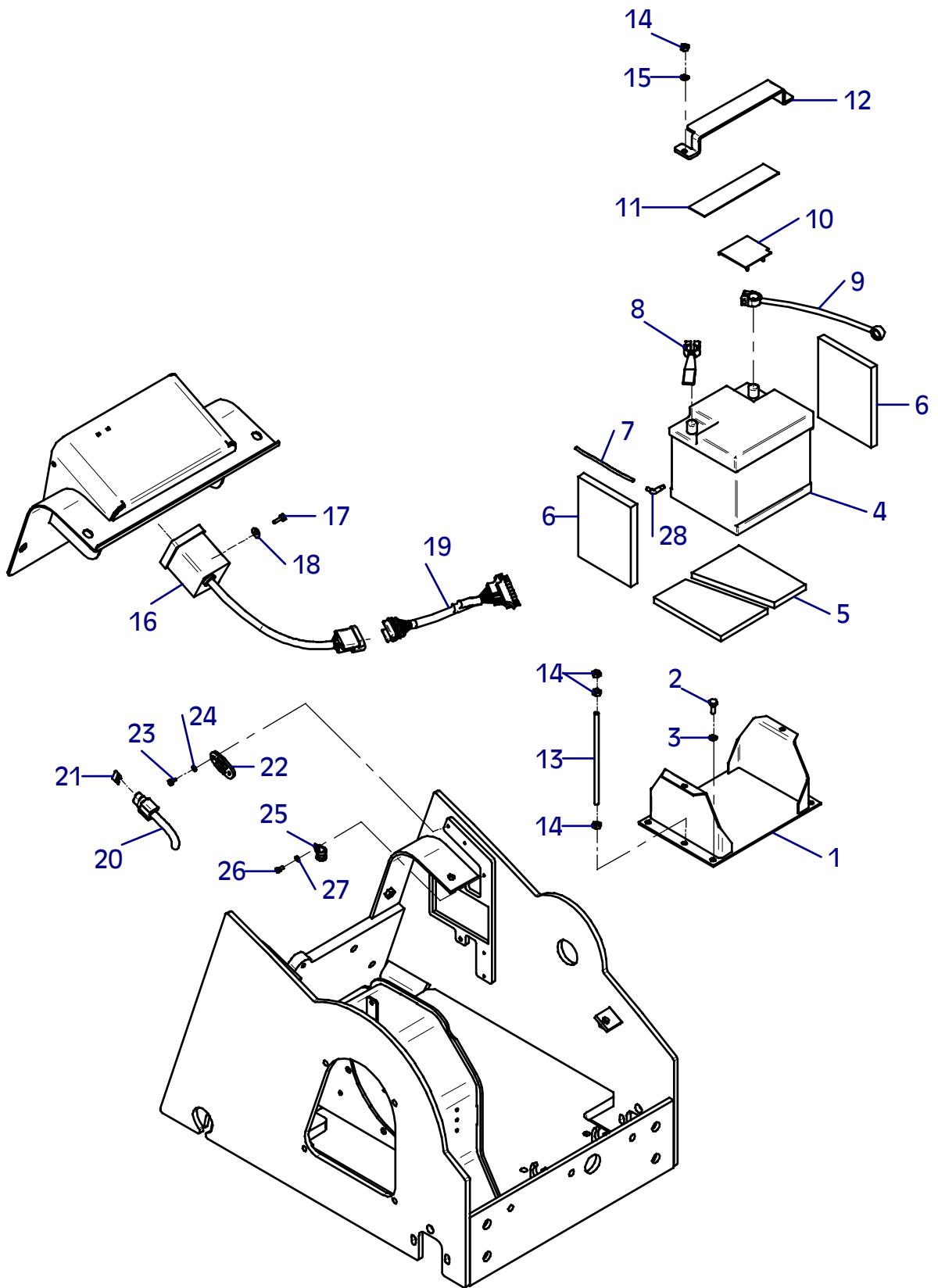

E 3197-0807

E 3198-0807

Position Ref.No. Repère Posizione Posicion	Menge Quantity Quantité Cantidad	Teile-Nr. Part-No. No. Référence Nr. d'Ordine No. Referenzia	Hinweis Hints Indications Indicazione Indicaciones	Position Ref. No. Repère Posizione Posicion	Menge Quantity Quantité Cantidad	Teile-Nr. Part-No. No. Référence Nr. d'Ordine No. Referenzia	Hinweis Hints Indications Indicazione Indicaciones
1	1	10003989		31	1	25048017	DIN125-A5,3
2	2	25038007	DIN933-M8x20	32	1	20026574	
3	2	20029003	VSK 8	33	4	25044080	DIN912-M5x25
4	1	20031502		34	4	20029006	VSK 5
5	2	10017185		35	1	21000353	
6	2	10015530					
7	1	20016289	0,4 m				
8	1	10001406					
9	1	10001416					
10	1	20025566					
11	1	30025028	0,19 m				
12	1	10015631					
13	2	25020028	DIN976-M8x200				
14	8	25031003	DIN934-M8				
15	2	20029003	VSK 8				
16	1	10001469					
17	2	25038002	DIN933-M6x16				
18	2	20029020	SKB 6				
19	1	11000620					
20	1	20026573					
21	4	25033029	ISO7380-M6x16-10.9				
22	4	20022001	Tensilock M6				
23	1	10001475					
24	1	20031579					
25	1	20031541					
26	1	20031532					
27	2	25038035	DIN933-M5x12				
28	2	25048017	DIN125-A5,3				
29	1	20007062					
30	1	25044119	DIN912-M5x10				

Hatz-CCD

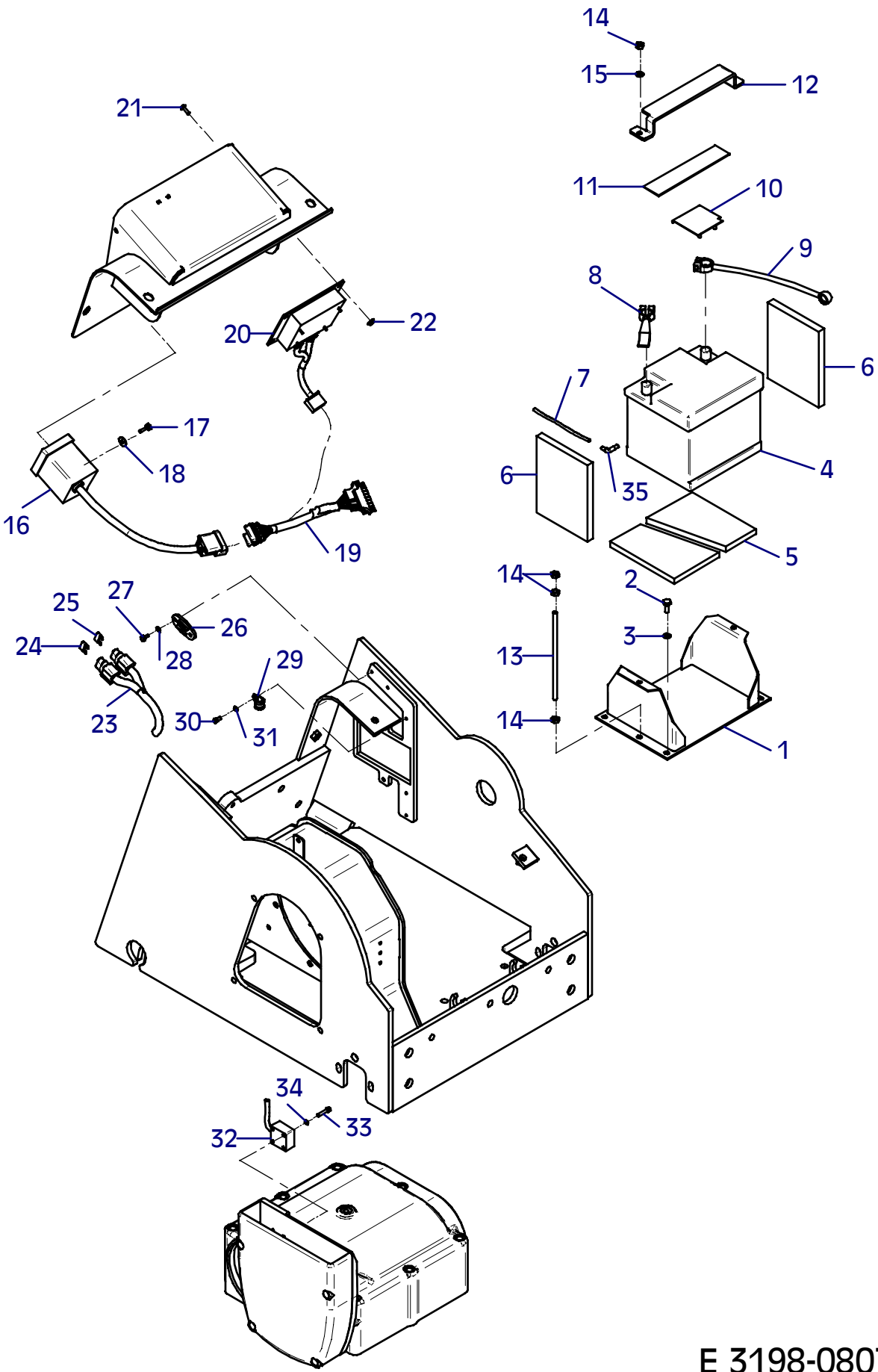

E 3283-0807

Position Ref.No. Repère Posizione Posicion	Menge Quantity Quantité Quantita Cantidad	Teile-Nr. Part-No. No. Référence Nr. d'Ordine No. Referenzia	Hinweis Hints Indications Indicazione Indicaciones	Position Ref. No. Repère Posizione Posicion	Menge Quantity Quantité Quantita Cantidad	Teile-Nr. Part-No. No. Référence Nr. d'Ordine No. Referenzia	Hinweis Hints Indications Indicazione Indicaciones
1	1	10003989		31	1	20026574	
2	2	25038007	DIN933-M8x20	32	4	25044080	DIN912-M5x25
3	2	20029003	VSK 8	33	4	20029006	VSK 5
4	1	20031502		34	1	21000353	
5	2	10017185		35	1	31000038	0,82 m
6	2	10015530		36	1	25044119	DIN912-M5x10
7	1	20016289	0,4 m	37	3	21000249	
8	1	10001406		38	1	21000407	
9	1	10001416					
10	1	20025566					
11	1	30025028	0,19 m				
12	1	10015631					
13	2	25020028	DIN976-M8x200				
14	8	25031003	DIN934-M8				
15	2	20029003	VSK 8				
16	1	11000552					
17	2	25038006	DIN933-M8x16				
18	2	20029003	VSK 8				
19	1	21000247					
20	3	20022022	Tensilock M5x12				
21	1	21000246					
22	4	25033029	ISO7380-M6x16-10.9				
23	4	20022001	Tensilock M6				
24	1	20031532					
25	2	25038035	DIN933-M5x12				
26	2	25048017	DIN125-A5,3				
27	1	20007062					
28	1	30025021	0,74 m				
29	1	20031541					
30	1	11000591					

Hatz-MSM

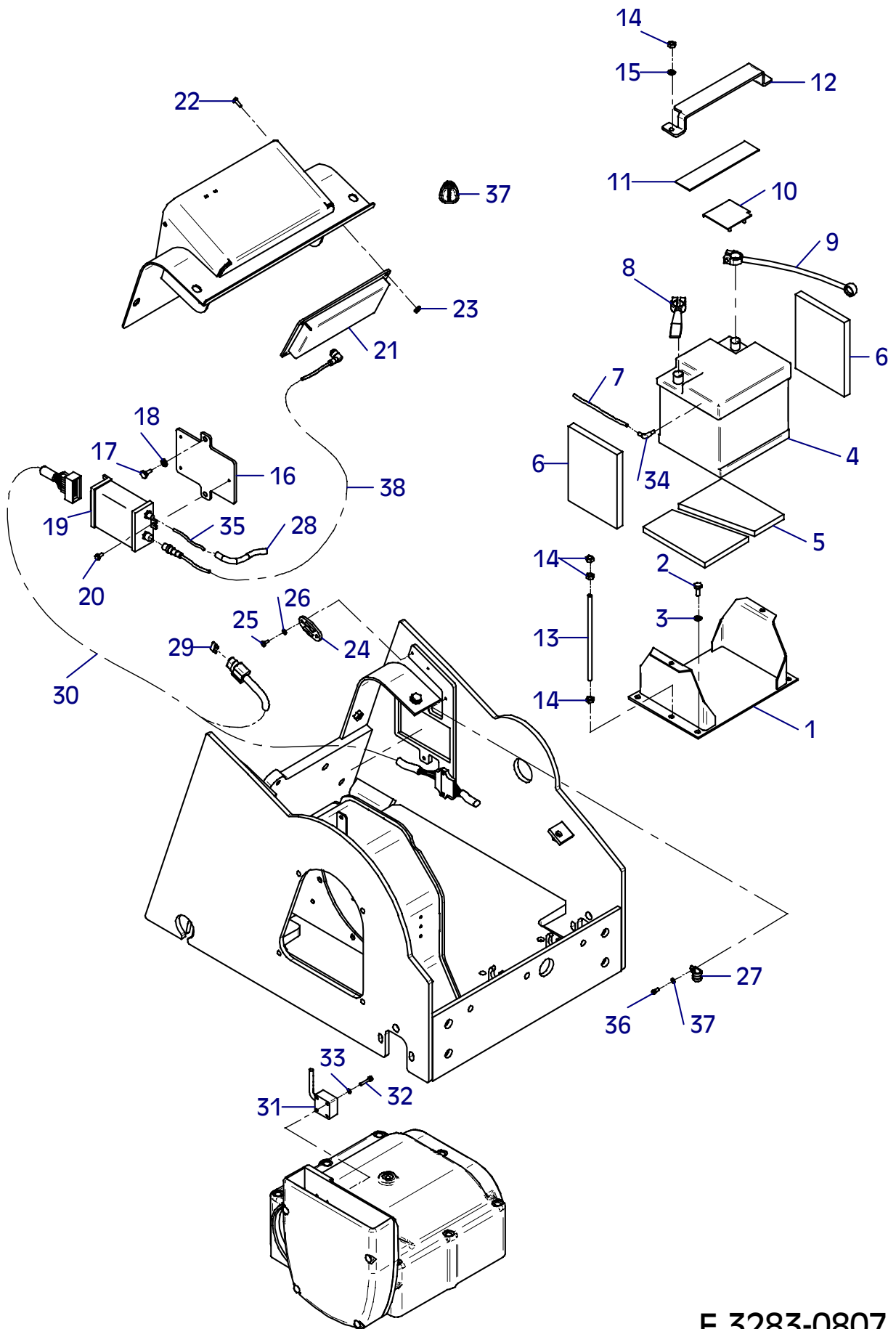

E 3283-0807

E 3199-0807

Position Ref.No. Repère Posizione Posicion	Menge Quantity Quantité Quantita Cantidad	Teile-Nr. Part-No. No. Référence Nr. d'Ordine No. Referenzia	Hinweis Hints Indications Indicazione Indicaciones	Position Ref. No. Repère Posizione Posicion	Menge Quantity Quantité Quantita Cantidad	Teile-Nr. Part-No. No. Référence Nr. d'Ordine No. Referenzia	Hinweis Hints Indications Indicazione Indicaciones
1	1	11000059		36	1	20022002	Tensilock M8
2	1	10017164		37	1	11000167	
3	5	25038014	DIN933-M10x25	38	8	25044045	DIN912-M16x40-10.9
4	5	20029033	SKM 10	39	8	20029029	
5	1	30047532		40	4	20026565	
6	4	25038006	DIN933-M8x16	41	1	11000078	
7	4	20029003	VSK 8	42	1	30047480	
8	4	25048002	DIN125-A8,4	43	3	25033030	ISO7380-M6x20-10.9
9	2	10017392		44	2	21000004	DIN71803-M6
10	2	11000043		45	2	25031012	DIN985-M6
11	4	25038014	DIN933-M10x25	46	1	11000079	
12	4	20029033	SKM 10	47	1	20005001	
13	2	10017359		48	1	25031012	DIN985-M6
14	8	25038006	DIN933-M8x16	49	1	21000004	DIN71803-M6
15	8	20029031	SKM 8	50	1	25031012	DIN985-M6
16	1	10022644		51	1	10017337	
17	1	20025680	0,76 m	52	2	21000031	
18	5	25044002	DIN912-M6x16	53	2	11000148	
19	5	20022001	Tensilock M6	54	1	25044037	DIN912-M10x55
20	1	11000435		55	2	25048003	DIN125-A10,5
21	5	25038014	DIN933-M10x25	56	1	25031014	DIN985-M10
22	5	20029033	SKM 10	57	1	20026481	
23	2	20007226		58	2	25025191	DIN80705-M20x1,5
24	1	25038003	DIN933-M6x20	59	2	20025019	
25	1	25048001	DIN125-A6,4	60	2	25048001	DIN125-A6,4
26	1	20029007	VSK 6	61	2	25040022	DIN931-M16x70
27	1	25031002	DIN934-M6	62	2	25031017	DIN985-M16
28	1	10017320		63	1	11000436	
29	2	25033030	ISO7380-M6x20-10.9	64	4	25047020	DIN7991-M6x16
30	2	25049033	DIN9021-6,4/18x1,6	65	4	20029007	VSK 6
31	2	25031012	DIN985-M6	66	4	25031002	DIN934-M6
32	1	20026544					
33	1	20026545					
34	1	25044063	DIN912-M8x35				
35	3	25049013	DIN440-R11,5				

Honda-CCD

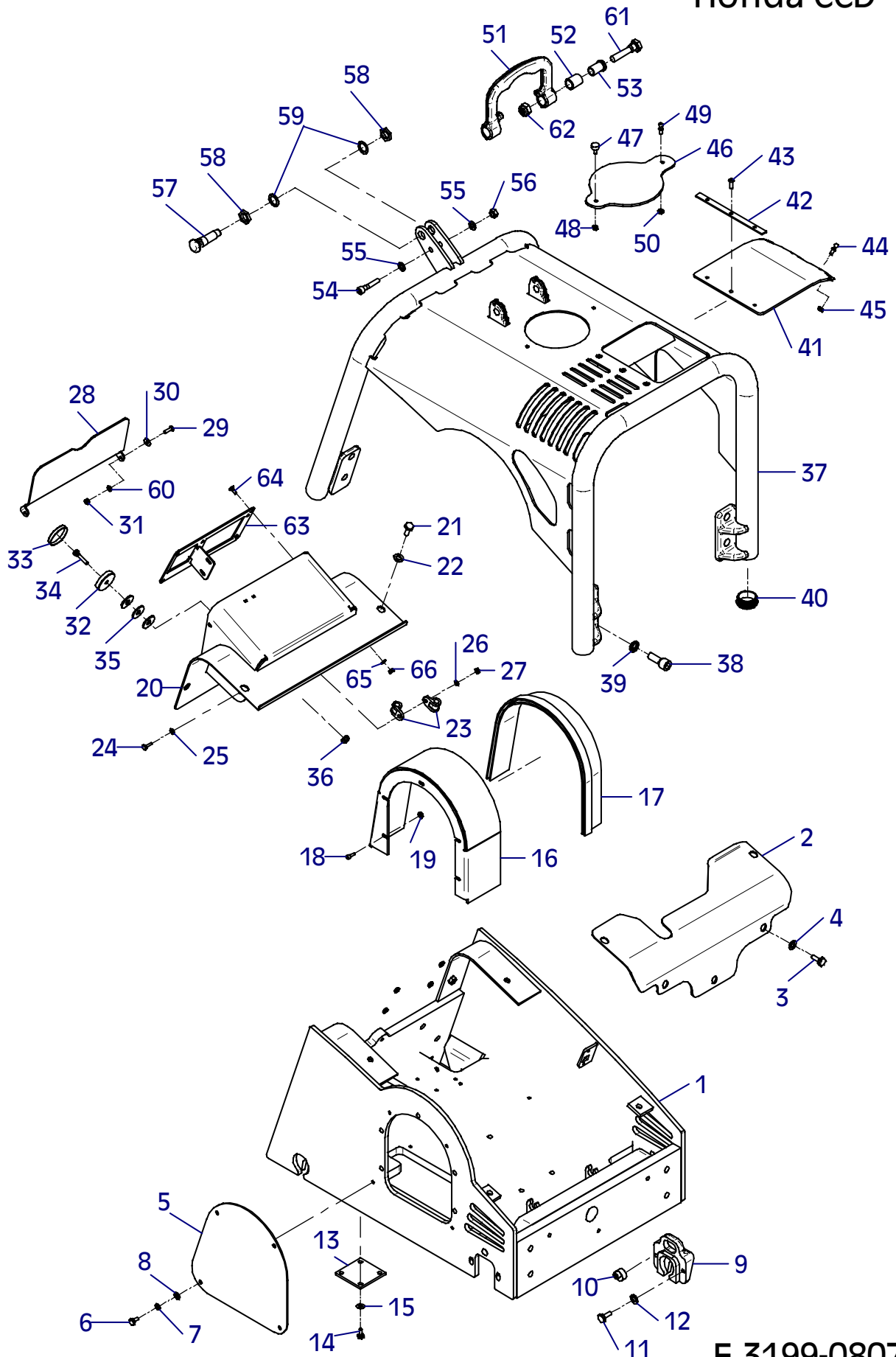

E 3199-0807

E 3138-1108

Position Ref.No. Repère Posizione Posicion	Menge Quantity Quantité Quantita Cantidad	Teile-Nr. Part-No. No. Référence Nr. d'Ordine No. Referenzia	Hinweis Hints Indications Indicazione Indicaciones	Position Ref. No. Repère Posizione Posicion	Menge Quantity Quantité Quantita Cantidad	Teile-Nr. Part-No. No. Référence Nr. d'Ordine No. Referenzia	Hinweis Hints Indications Indicazione Indicaciones
1	1	20001247		31	1	25031002	DIN934-M6
2	2	10017175		32	1	20007007	
3	4	20025158		33	1	25048001	DIN125-A6,4
4	4	21000472	DIN931-M10x75	34	1	25038002	DIN933-M6x16
5	4	25049020	DIN7349-10,5	35	1	21000335	
6	4	20029025		36	1	20026383	
7	3	25031004	DIN934-M10	37	1	21000023	
8	2	25031024	DIN936-M10	38	1	11000104	
9	1	20026204					
10	1	25008011	DIN7603-12x18x1,5				
11	1	10017191					
12	4	25038006	DIN933-M8x16				
13	4	20025122					
14	1	21000387					
15	1	25002175					
16	1	10017040					
17	1	20026475					
18	1	25040065	DIN931-M8x40				
19	1	20007226					
20	1	25038002	DIN933-M6x16				
21	1	20025704					
22	1	20025434					
23	1	20026559					
24	1	20007024					
25	1	10017036					
26	1	25038002	DIN933-M6x16				
27	1	20029007	VSK 6				
28	1	20015175					
29	1	25044065	DIN912-M6x25				
30	1	20029007	VSK 6				

Honda-CCD

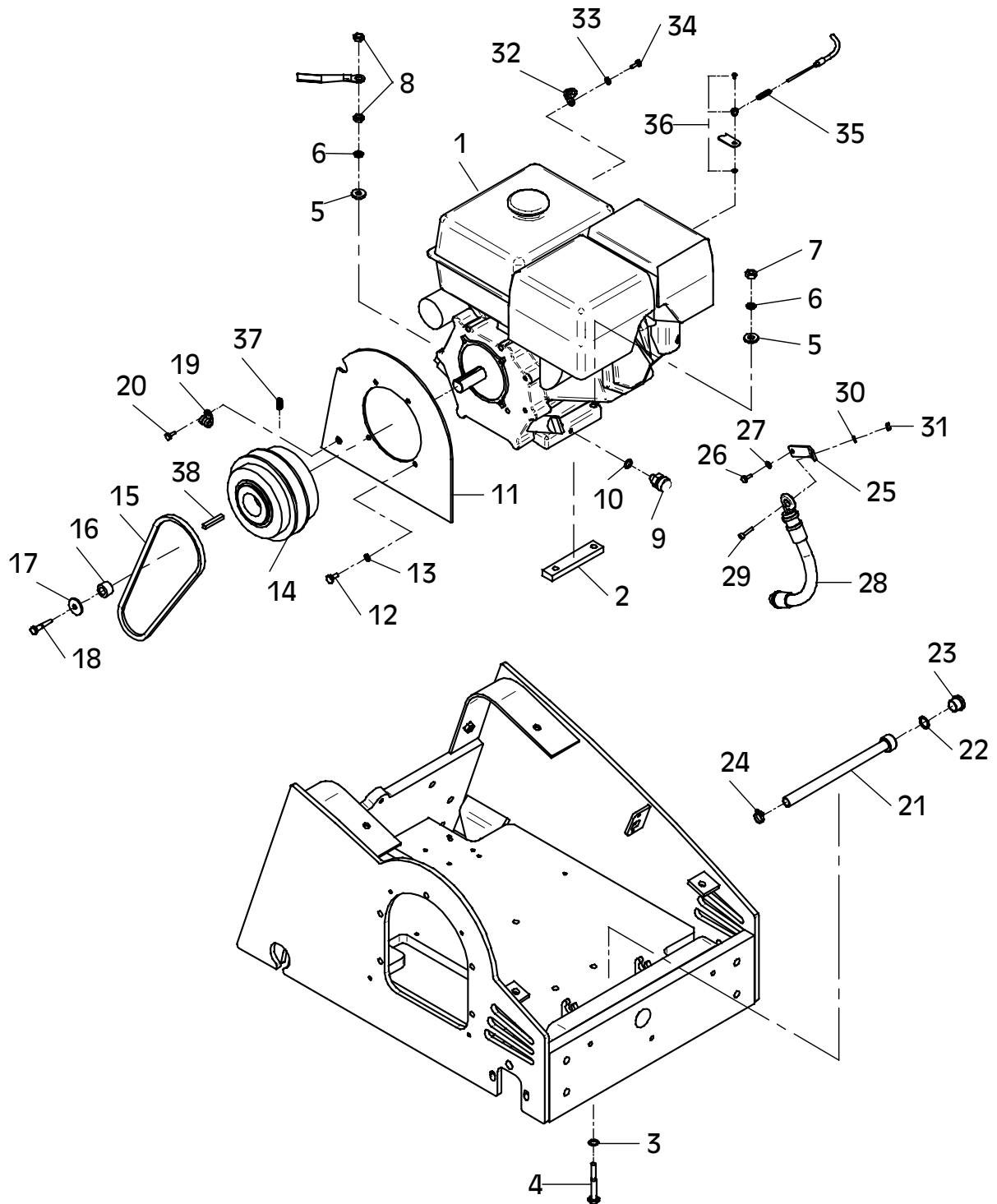

E 3138-1108

E 3316-0708

Position Ref.No. Repère Posizione Posicion	Menge Quantity Quantité Quantita Cantidad	Teile-Nr. Part-No. No. Référence Nr. d'Ordine No. Referenzia	Hinweis Hints Indications Indicazione Indicaciones	Position Ref. No. Repère Posizione Posicion	Menge Quantity Quantité Quantita Cantidad	Teile-Nr. Part-No. No. Référence Nr. d'Ordine No. Referenzia	Hinweis Hints Indications Indicazione Indicaciones
1	1	21000387					
2	2	20002268					
3	2	20002289					
4	2	21000117					
5	3	21000433					

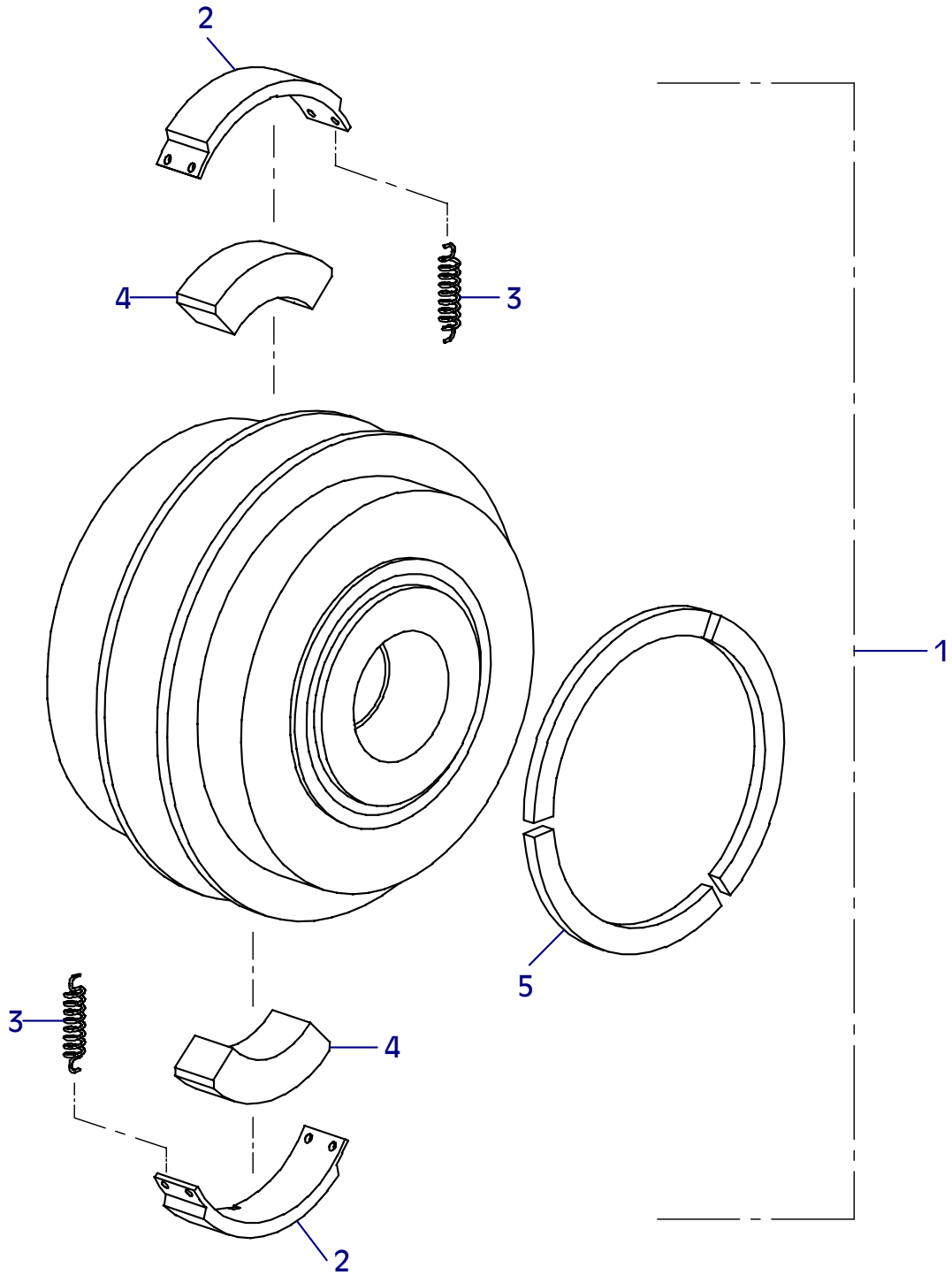

E 3316-0708

E 3139-0807

Position Ref.No. Repère Posizione Posicion	Menge Quantity Quantité Cantidad	Teile-Nr. Part-No. No. Référence Nr. d'Ordine No. Referenzia	Hinweis Hints Indications Indicazione Indicaciones	Position Ref. No. Repère Posizione Posicion	Menge Quantity Quantité Cantidad	Teile-Nr. Part-No. No. Référence Nr. d'Ordine No. Referenzia	Hinweis Hints Indications Indicazione Indicaciones
1	1	10003989		31	2	25044119	DIN912-M5x10
2	2	25038007	DIN933-M8x20	32	2	25048017	DIN125-A5,3
3	2	20029003	VSK 8	33	1	20031526	
4	2	10017185		34	1	25044119	DIN912-M5x10
5	1	20031502		35	1	25048017	DIN125-A5,3
6	2	10015530		36	1	20031034	
7	1	20016289	0,4 m	37	1	20026514	
8	1	10001470		38	1	20007033	
9	1	10001472		39	1	25044076	DIN912-M5x16
10	1	20025566		40	1	20029006	VSK 5
11	1	30025028	0,19 m	41	2	25044003	DIN912-M6x20
12	1	10015631		42	2	20029007	VSK 6
13	2	25020028	DIN976-M8x200	43	1	20007062	
14	8	25031003	DIN934-M8	44	1	25038013	DIN933-M10x20
15	2	20029003	VSK 8	45	1	25048003	DIN125-A10,5
16	1	25049026	DIN7349-8,4	46	1	21000353	
17	1	20007077					
18	1	25048002	DIN125-A8,4				
19	1	25038007	DIN933-M8x20				
20	1	10001469					
21	2	25038002	DIN933-M6x16				
22	2	20029020	SKB 6				
23	1	20026573					
24	4	25033029	ISO7380-M6x16-10.9				
25	1	10001473					
26	1	20026574					
27	4	25044080	DIN912-M5x25				
28	4	20029006	VSK 5				
29	1	10001471					
30	1	20031532					

E 3200-0807

Position Ref.No. Repère Posizione Posicion	Menge Quantity Quantité Quantita Cantidad	Teile-Nr. Part-No. No. Référence Nr. d'Ordine No. Referenzia	Hinweis Hints Indications Indicazione Indicaciones	Position Ref. No. Repère Posizione Posicion	Menge Quantity Quantité Quantita Cantidad	Teile-Nr. Part-No. No. Référence Nr. d'Ordine No. Referenzia	Hinweis Hints Indications Indicazione Indicaciones
1	1	11000017		41	2	20013284	
2	1	10022520		42	2	21000009	
3	8	25038013	DIN933-M10x20	43	2	10017396	
4	8	20029033	SKM 10	44	2	25044035	DIN912-M12x25
5	2	10016290		45	2	20029013	VSKZ 12
6	4	25044055	DIN912-M8x50	46	2	20025593	
7	4	20029003	VSK 8	47	1	11000038	
8	4	25031003	DIN934-M8	48	4	25038007	DIN933-M8x20
9	2	20026491		49	4	20029003	VSK 8
10	2	20004023		50	1	20008069	
11	2	20026492		51	1	10016307	
12	2	10016291		52	1	10016305	
13	2	25040066	DIN931-M16x55	53	2	20013285	
14	2	20029002	VSK 16	54	1	20013282	
15	1	11000050		55	1	20013286	
16	2	25044039	DIN912-M16x40	56	1	10016303	
17	2	20029029		57	1	10016308	
18	1	11000051		58	4	25044006	DIN912-M8x25
19	2	25044039	DIN912-M16x40	59	4	20025122	
20	2	20029029		60	2	25047022	DIN7991-M6x12
21	4	25038008	DIN933-M8x25	61	1	20020562	
22	4	20029003	VSK 8	62	1	10016358	Hatz
23	1	11000037		62	1	10016100	Honda
24	1	25025305		63	1	20018080	Hatz
25	1	21000033	DIN936-M20	63	1	20018160	Honda
26	1	21000008		64	1	20018082	
27	1	20007089		65	1	20018081	Hatz
28	1	25040004	DIN931-M8x55	65	1	20018161	Honda
29	1	25048002	DIN125-A8,4	66	2	25038070	DIN933-M6x30
30	1	20016135	0,56 m	67	2	20029007	VSK 6
31	1	20007089		68	1	20016367	
32	1	25040027	DIN931-M8x35	69	1	20018143	
33	1	20029003	VSK 8	70	2	25038008	DIN933-M8x25
34	1	20016135	0,05 m	71	2	25048002	DIN125-A8,4
35	1	10016309					
36	1	25030003	DIN908-M24x1,5				
37	1	25008008	DIN7603-24x32x2				
38	1	20025764					
39	1	10017395					
40	2	10017398					

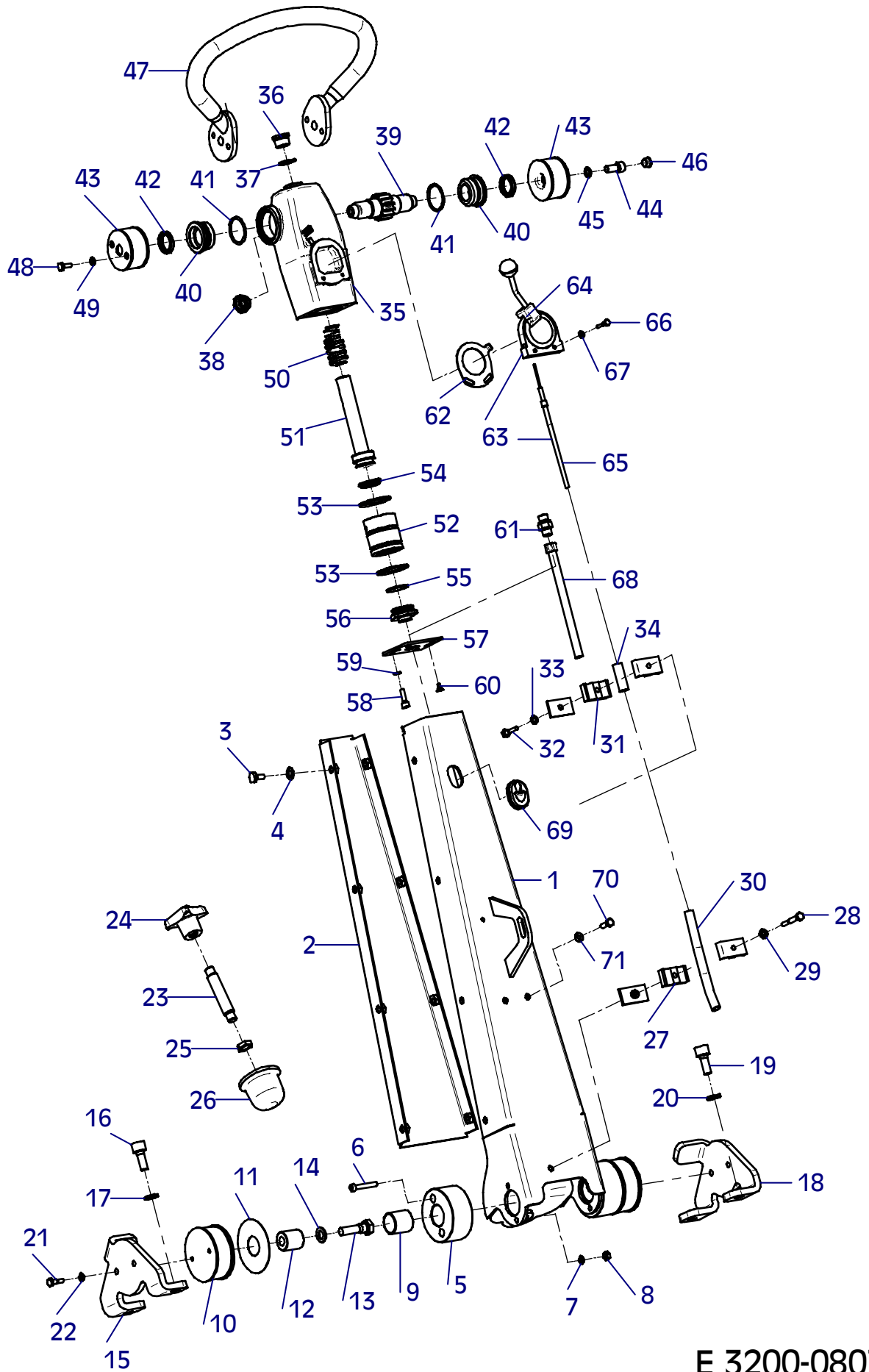

E 3200-0807

E 3007-0202

Position Ref.No. Repère Posizione Posicion	Menge Quantity Quantité Quantita Cantidad	Teile-Nr. Part-No. No. Référence Nr. d'Ordine No. Referenzia	Hinweis Hints Indications Indicazione Indicaciones	Position Ref. No. Repère Posizione Posicion	Menge Quantity Quantité Quantita Cantidad	Teile-Nr. Part-No. No. Référence Nr. d'Ordine No. Referenzia	Hinweis Hints Indications Indicazione Indicaciones
1	1	10016451					
2	2	10016452					
3	6	25038076	DIN933-M12x100				
4	6	20029004	VSK 12				
5	6	25031005	DIN934-M12				

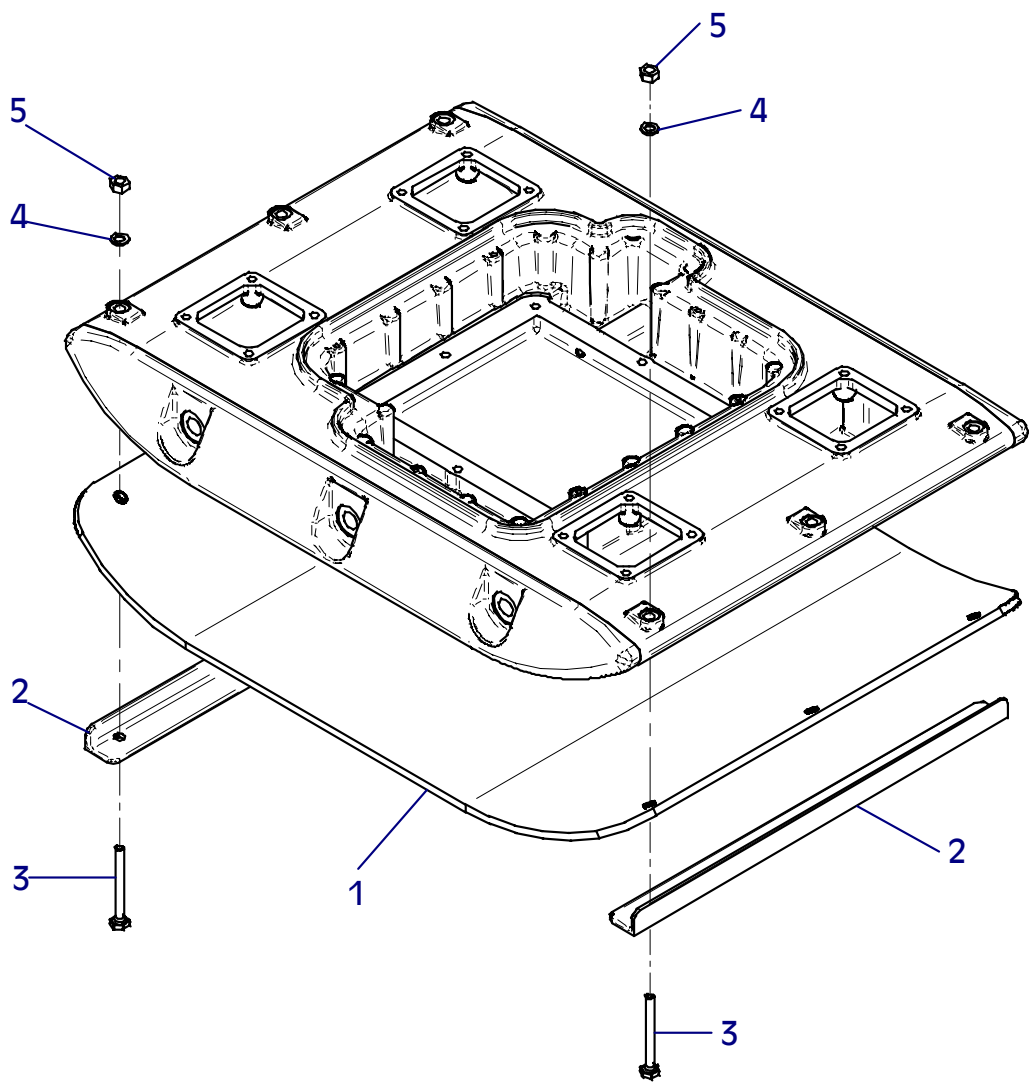

E 3007-0202

E 3041-0402

Position Ref.No. Repère Posizione Posicion	Menge Quantity Quantité Quantita Cantidad	Teile-Nr. Part-No. No. Référence Nr. d'Ordine No. Referenzia	Hinweis Hints Indications Indicazione Indicaciones	Position Ref. No. Repère Posizione Posicion	Menge Quantity Quantité Quantita Cantidad	Teile-Nr. Part-No. No. Référence Nr. d'Ordine No. Referenzia	Hinweis Hints Indications Indicazione Indicaciones
1	2	10016443					
2	6	20029009	VSK 20				
3	6	25038085	DIN933-M20x100-10.9				
4	1	10016699					
5	2	10016702					
6	6	25038076	DIN933-M12x100				
7	6	20029004	VSK 12				
8	6	25031005	DIN934-M12				

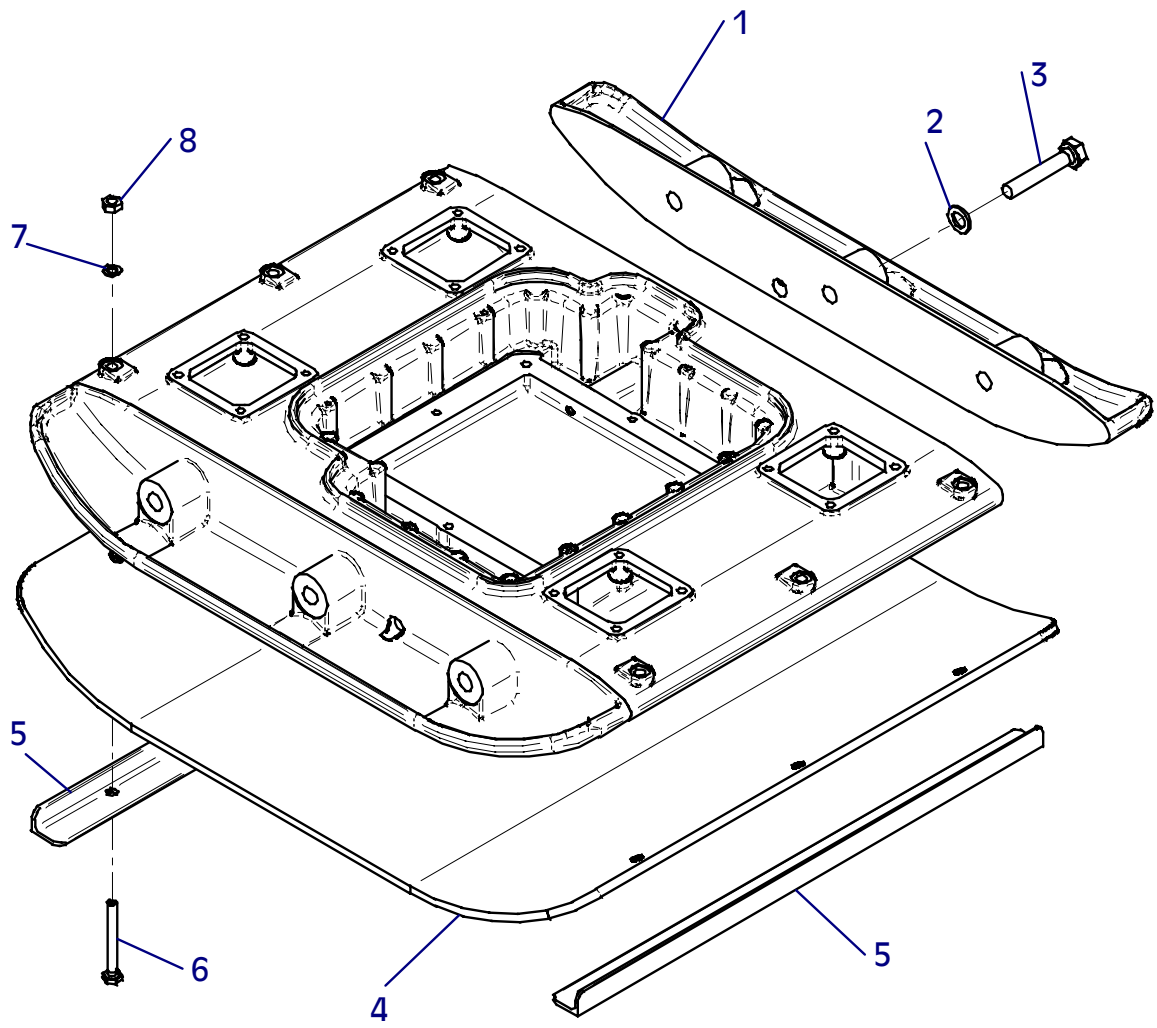

E 3041-0402

E 3134-0304

Position Ref.No. Repère Posizione Posicion	Menge Quantity Quantité Quantita Cantidad	Teile-Nr. Part-No. No. Référence Nr. d'Ordine No. Referenzia	Hinweis Hints Indications Indicazione Indicaciones	Position Ref. No. Repère Posizione Posicion	Menge Quantity Quantité Quantita Cantidad	Teile-Nr. Part-No. No. Référence Nr. d'Ordine No. Referenzia	Hinweis Hints Indications Indicazione Indicaciones
1	2	10016746					
2	6	25038032	DIN933-M20x40				
3	6	20029009	VSK 20				

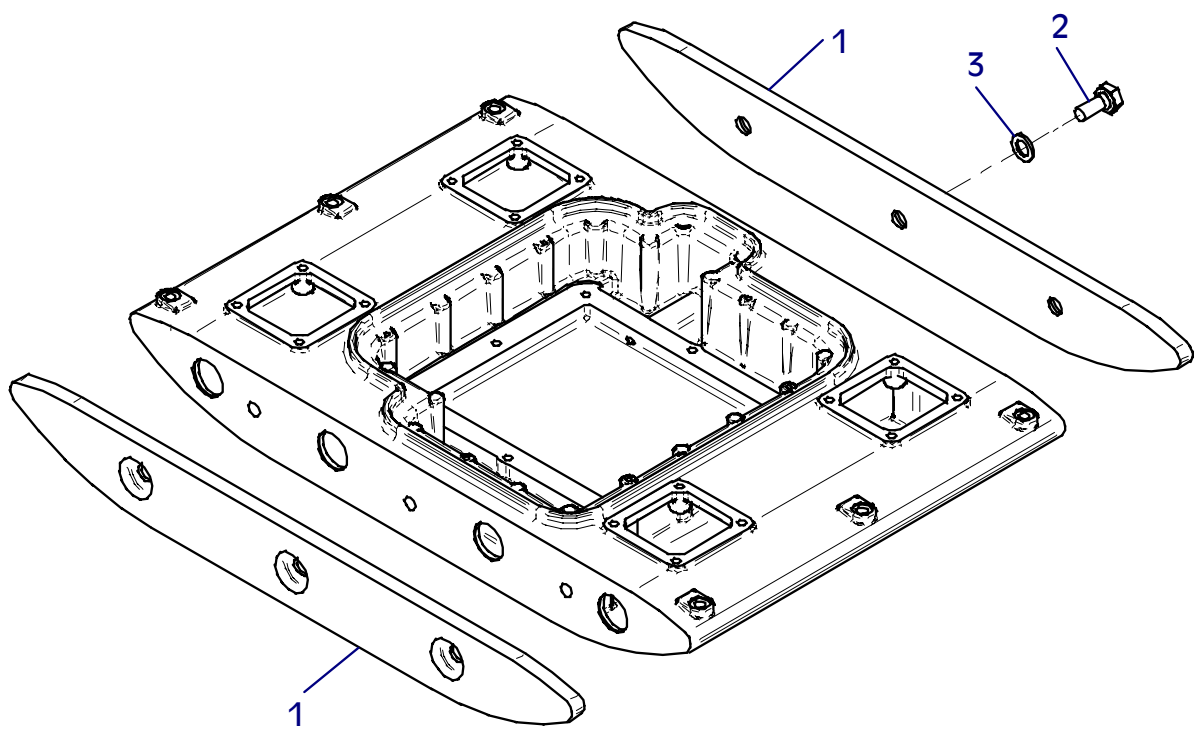

E 3134-0304

E 3042-0805

Position Ref.No. Repère Posizione Posicion	Menge Quantity Quantité Quantita Cantidad	Teile-Nr. Part-No. No. Référence Nr. d'Ordine No. Referenzia	Hinweis Hints Indications Indicazione Indicaciones	Position Ref. No. Repère Posizione Posicion	Menge Quantity Quantité Quantita Cantidad	Teile-Nr. Part-No. No. Référence Nr. d'Ordine No. Referenzia	Hinweis Hints Indications Indicazione Indicaciones
1	1	10006815					
2	1	10006816					
3	1	20005004					
4	1	20029003	VSK 8				
5	1	25031003	DIN934-M8				
6	2	25048002	DIN125-A8,4				
7	2	25038008	DIN933-M8x25				
8	2	20029003	VSK 8				
9	2	25031003	DIN934-M8				
10	1	20015034					
11	1	20015072					

Hatz / Hatz-CCD

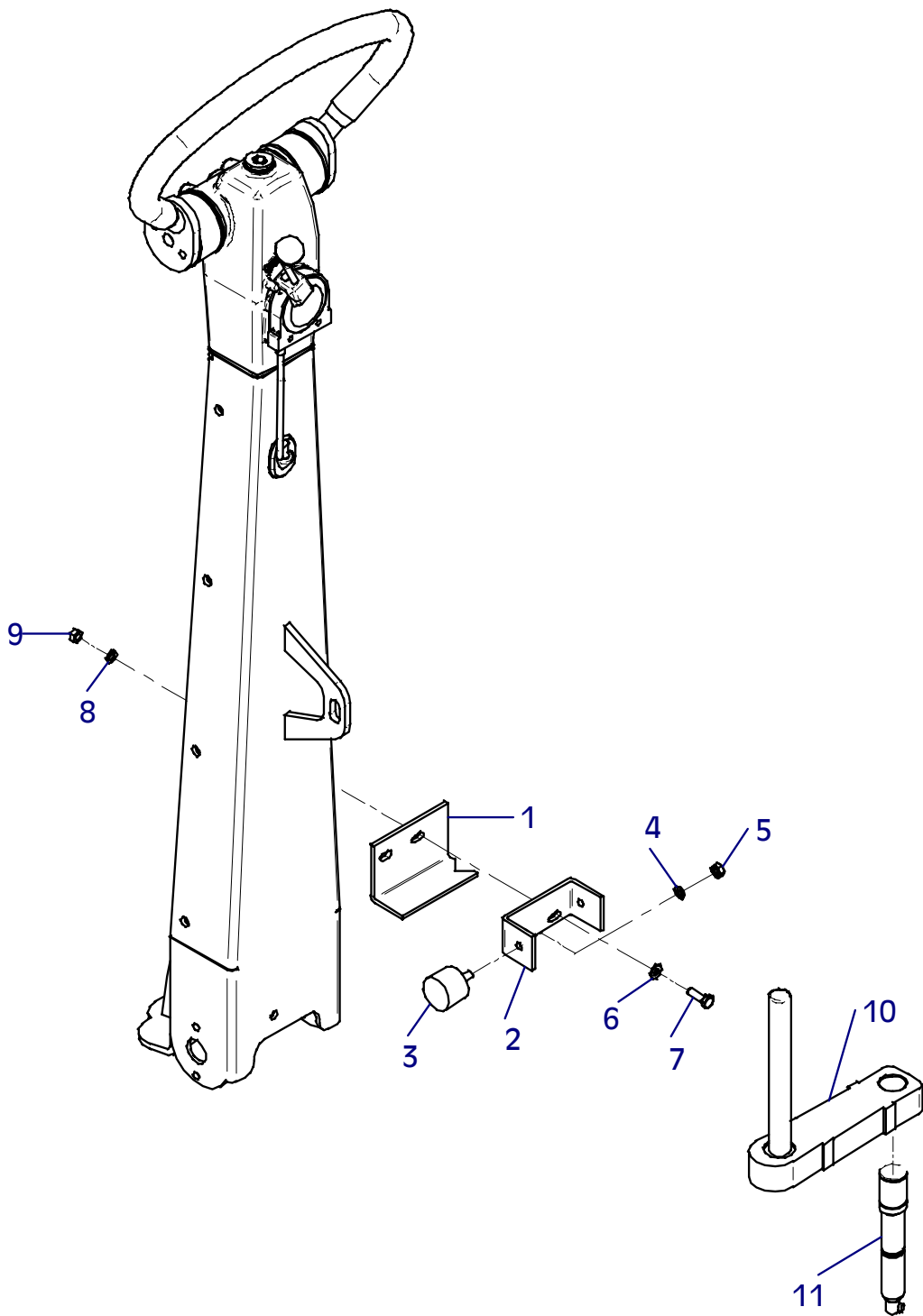

E 3042-0805

**Wenn Sie Fragen und Anregungen haben, oder sonstige Informationen benötigen,
wenden Sie sich bitte an eine der unten genannten Adressen:**

**For questions and further information refer to one of the
following addresses:**

<p>In Deutschland</p> <p>In Germany</p>	<p>WEBER Maschinenteknik GmbH Postfach 2153 57329 Bad Laasphe – Rückershausen</p> <p>Information / information: E-mail: info@webermt.de</p> <p>Ersatzteile / spare parts: E-mail: parts@webermt.de</p>	<p>Telefon / phone:</p> <p>Telefax / fax:</p> <p>Telefax / fax:</p>	<p>+49 (0) 2754 / 3980 Zentrale / switchboard</p> <p>+49 (0) 2754 / 398101 Zentrale / switchboard</p> <p>+49 (0) 2754 / 398102 Ersatzteile / spare parts direct dial</p>
<p>In Holland</p> <p>In Netherlands</p>	<p>WEBER Maschinenteknik B.V. Graafschap Hornelaan 159 6001 AC Weert</p> <p>E-mail: info@webermt.nl</p>	<p>Telefon / phone:</p> <p>Telefax / fax:</p>	<p>+31 (0) 495 / 530215</p> <p>+31 (0) 495 / 541839</p>
<p>In Frankreich</p> <p>In France</p>	<p>WEBER Technologie S.A.R.L. 26, rue d'Arsonval 69680 Chassieu</p> <p>E-mail: france@webermt.com</p>	<p>Telefon / phone:</p> <p>Telefax / fax:</p>	<p>+33 (0) 472 / 791020</p> <p>+33 (0) 472 / 791021</p>
<p>In Polen</p> <p>In Poland</p>	<p>WEBER Maschinenteknik SP.ZO.O. ul. Grodziska 7 05-830 Stara Wies / Nadarzyn</p> <p>E-mail: info@webermt.com.pl</p>	<p>Telefon / phone:</p> <p>Telefax / fax:</p>	<p>+48 (0) 22 / 7397080</p> <p>+48 (0) 22 / 7397081</p> <p>+48 (0) 22 / 7397082</p>
<p>In USA, Kanada</p> <p>In USA, Canada</p>	<p>WEBER Machine (USA), Inc. 40 Johnson Ave 112 Bangor, ME 04401 USA</p> <p>E-mail: usa@webermt.com</p>	<p>Telefon / phone:</p> <p>Telefax / fax:</p>	<p>+1 (0) 207 / 9474990</p> <p>+1 (0) 207 / 9475452</p>
<p>In Südamerika</p> <p>In South America</p>	<p>WEBER Maschinenteknik do Brasil Máquinas Para Construção Ltda. Rua Curt Wacker, nº 45 93332 – 200 Novo Hamburgo, RS Brasil</p> <p>E-mail: webermt@webermt.com.br</p>	<p>Telefon / phone:</p> <p>Telefax / fax:</p>	<p>+55 (0) 51 / 5873044</p> <p>+55 (0) 51 / 5872271</p>

<http://www.webermt.com>

