

SRV 650

0170351



Spare parts
Spares
Pièces de rechange
Piezas de recambio
Ricambi
Peças de reposição
Pieșe de schimb
Náhradných dielov
Reserve Teile
Części zamienne



Weber Maschinenteknik GmbH
D- 57334 Bad Laasphe / Germany
Tel. +49 (0) 2754 / 398-0
Fax. +49 (0)2754 / 398-101
E-Mail: info@webermt.de
www.webermt.com

BITTE, NOTIEREN SIE SERIENNUMMER UND MOTORNUMMER IHRER MASCHINE:

PLEASE WRITE DOWN SERIALNUMBERS OF MACHINE AND ENGINE:

NOTEZ SVP LE NUMERO DE SERIE ET LE NUMERO DU MOTEUR DE VOTRE MACHINE:

SI PREGA DI ANNOTARE SEMPRE I NUMERI DI SERIE SIA DELLA VS. MACCHINA CHE DEL MOTORE:

MAQUINA: ROGAMOS ANOTEN EL NUMERO DE SERIE Y NUMERO DE MOTOR DE SU MAQUINA:

MASCHINE
MACHINE
MACCHINA
MAQUINA

#

MOTOR
ENGINE
MOTEUR
MOTORE

#

ZUR VERMEIDUNG VON FEHLLIEFERUNGEN UND VERZÖGERUNGEN SIND BEI DER BESTELLUNG VON ERSATZTEILEN FOLGENDE ANGABEN UNBEDINGT ERFORDERLICH:

- MASCHINENTYP
- SERIENNUMMER DER MASCHINE
- SERIENNUMMER DES MOTORS (BEI MOTORTEILEN)
- TEILENUMMER
- BESTELLMENGE

TO AVOID ERRORS IN DELIVERY PLEASE STATE THESE PARTICULARS WHEN ORDERING:

- TYPE OF MACHINE
- SERIAL NO. OF MACHINE
- SERIAL NO. OF ENGINE (ON ENGINE PARTS)
- PART-NO.
- QUANTITY REQUIRED

AFIN D'EVITER DES ERREURS DE COMMANDE ET DES RETARDS DE LIVRAISON IL EST NECESSAIRE D'INDIQUER LES CARACTERISTIQUES SUIVANTES:

- TYPE DE MACHINE
- LE NUMERO DE SERIE DE LA MACHINE
- LE NUMERO DE SERIE DU MOTEUR
- LE NUMERO D'IDENTITE DE LA PIECE
- LA QUANTITE SOUHAITEE

ONDE EVITARE DISGUIDI E RITARDI NELLE CONSEGNE DIE RICAMBI SI PREGA DI INDICARE SEMPRE:

- TIPO DELLA MACCHINA
- NUMERO DI SERIE DELLA MACCHINA
- NUMERO DI SERIE DEL MOTORE (SE SI RICHIEDONO PEZZI DEL MOTORE)
- NUMERO D'ORDINE DIE SINGOLI RICAMBI
- QUANTITA

A FI DE EVITAR ERRORES DE ENTREGA, ROGAMOS INDIQUEN LOS SIGUIENTES DATOS CUANDO PASE PEDIDOS DE RECAMBIO:

- MODELO DE MAQUINA
- NO. DE SERIE DE LA MAQUINA
- NO. DE SERIE DEL MOTOR (EN PIEZAS PARA MOTOR)
- REFERENCIA DEL RECAMBIO
- CANTIDAD PEDIDA

E 3269-1007

Position Ref.No. Repère Posizione Posicion	Menge Quantity Quantité Quantita Cantidad	Teile-Nr. Part-No. No. Référence Nr. d'Ordine No. Referenzia	Hinweis Hints Indications Indicazione Indicaciones	Position Ref. No. Repère Posizione Posicion	Menge Quantity Quantité Quantita Cantidad	Teile-Nr. Part-No. No. Référence Nr. d'Ordine No. Referenzia	Hinweis Hints Indications Indicazione Indicaciones
1	1	10001478					
2	1	10017003					
3	2	21000351	DIN608-M12x95				
4	2	21000352	DIN608-M12x150				
5	12	20029032	SKM 12				
6	4	25031015	DIN985-M12				

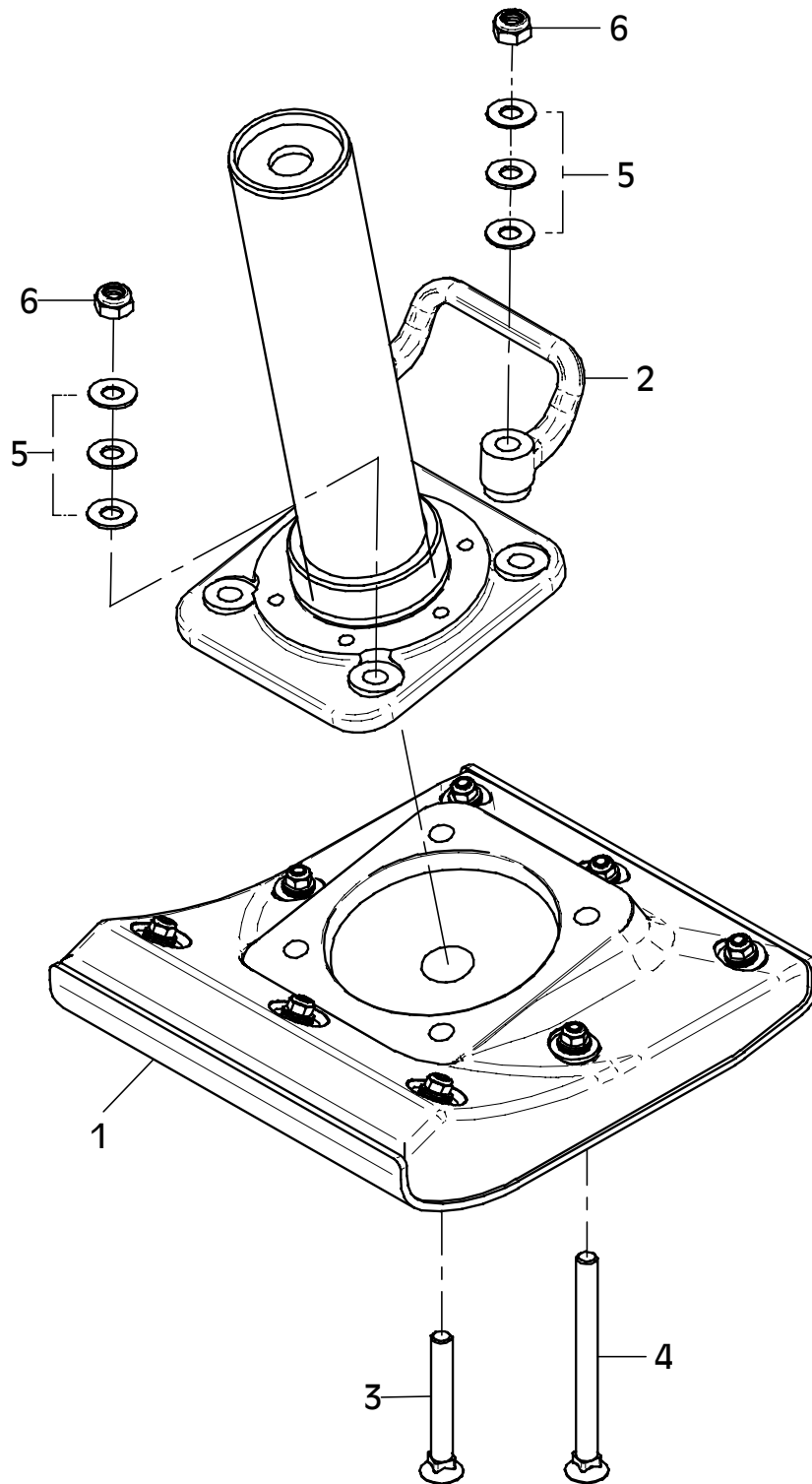

E 3460-0312

Position Ref.No. Repère Posizione Posicion	Menge Quantity Quantité Quantità Cantidad	Teile-Nr. Part-No. No. Référence Nr. d'Ordine No. Referenzia	Hinweis Hints Indications Indicazione Indicaciones	Position Ref. No. Repère Posizione Posicion	Menge Quantity Quantité Quantità Cantidad	Teile-Nr. Part-No. No. Référence Nr. d'Ordine No. Referenzia	Hinweis Hints Indications Indicazione Indicaciones
1	1	11001147					
2	4	25038016	DIN933-M10x35				
3	4	20029001	VSK 10				
4	1	10006970					
5	1	25025157					
6	1	10006969					
7	1	10006972					
8	2	10006971					
9	1	20025520					
10	2	20007039					
11	1	10006973					
12	1	25030014	DIN910-G1/2"				
13	1	25008007	DIN7603-21x26x1,5				
14	1	20013068					
15	1	11000574					
16	1	20013067					
17	1	11000334					
18	6	25038011	DIN933-M8x40				
19	6	20029003	VSK 8				
20	1	10022668					
21	1	10006965					
22	2	20008053					
23	2	20008035					
24	1	21000297					

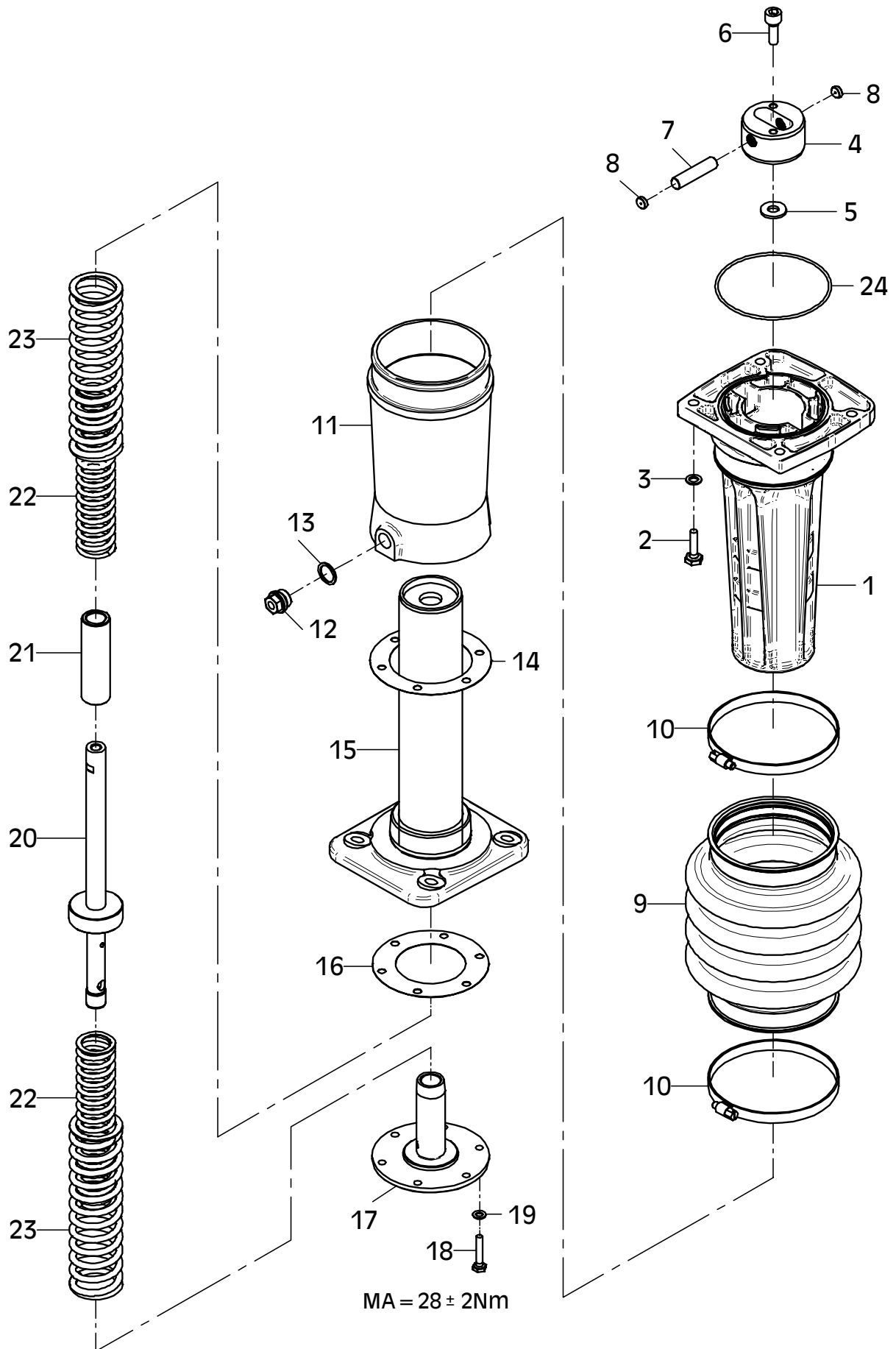

E 3460-0312

E 3461-0312

Position Ref.No. Repère Posizione Posicion	Menge Quantity Quantité Quantita Cantidad	Teile-Nr. Part-No. No. Référence Nr. d'Ordine No. Referenzia	Hinweis Hints Indications Indicazione Indicaciones	Position Ref. No. Repère Posizione Posicion	Menge Quantity Quantité Quantita Cantidad	Teile-Nr. Part-No. No. Référence Nr. d'Ordine No. Referenzia	Hinweis Hints Indications Indicazione Indicaciones
1	1	11000379					
2	1	11000380					
3	1	21000298					
4	2	25044007	DIN912-M8x30				
5	2	25044009	DIN912-M8x45				
6	2	25044046	DIN912-M8x55				
7	6	20029003	VSK 8				
8	6	25048002	DIN125-A8,4				
9	1	10007093					
10	1	25001257					
11	1	25035025	DIN472-l24x1,2				
12	1	11000383					
13	1	25001206					
14	1	25034003	DIN471-A20x1,2				
15	1	25035008	DIN472-l42x1,75				
16	1	21000330					
17	1	11000333					
18	1	25035010	DIN472-l72x2,5				
19	1	25001012					
20	1	25034006	DIN471-A35x1,5				
21	1	25001047					
22	1	25034016	DIN471-A25x1,2				

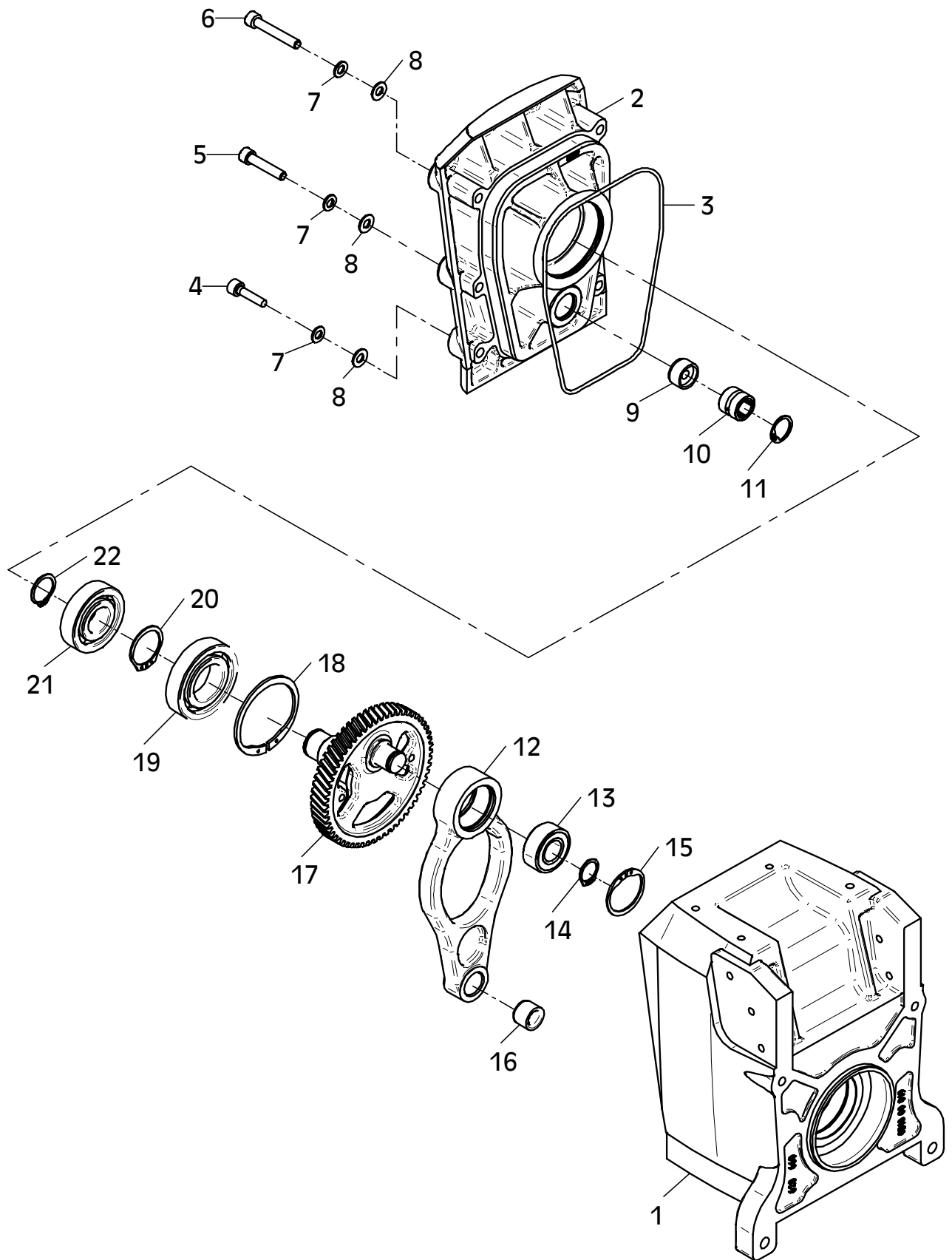

E 3461-0312

E 3462-0312

Position Ref.No. Repère Posizione Posicion	Menge Quantity Quantité Quantita Cantidad	Teile-Nr. Part-No. No. Référence Nr. d'Ordine No. Referenzia	Hinweis Hints Indications Indicazione Indicaciones	Position Ref. No. Repère Posizione Posicion	Menge Quantity Quantité Quantita Cantidad	Teile-Nr. Part-No. No. Référence Nr. d'Ordine No. Referenzia	Hinweis Hints Indications Indicazione Indicaciones
1	1	10009652					
2	1	25017033					
3	1	25035003	DIN472-I62x2				
4	1	25001045					
5	1	25034006	DIN471-A35x1,5				
6	1	11000750					
7	1	11000749					
8	5	25038008	DIN933-M8x25				
9	5	20029003	VSK 8				
10	1	20007004					
11	1	25038012	DIN933-M8x45				
12	1	25048002	DIN125-A8,4				
13	2	25049026	DIN7349-8,4				
14	2	20005021					
15	2	20022002	Tensilock M8				
16	1	21000459					
17	1	21000460					
18	1	41000757					
19	4	25044007	DIN912-M8x30				
20	4	20029003	VSK 8				
21	4	25048002	DIN125-A8,4				

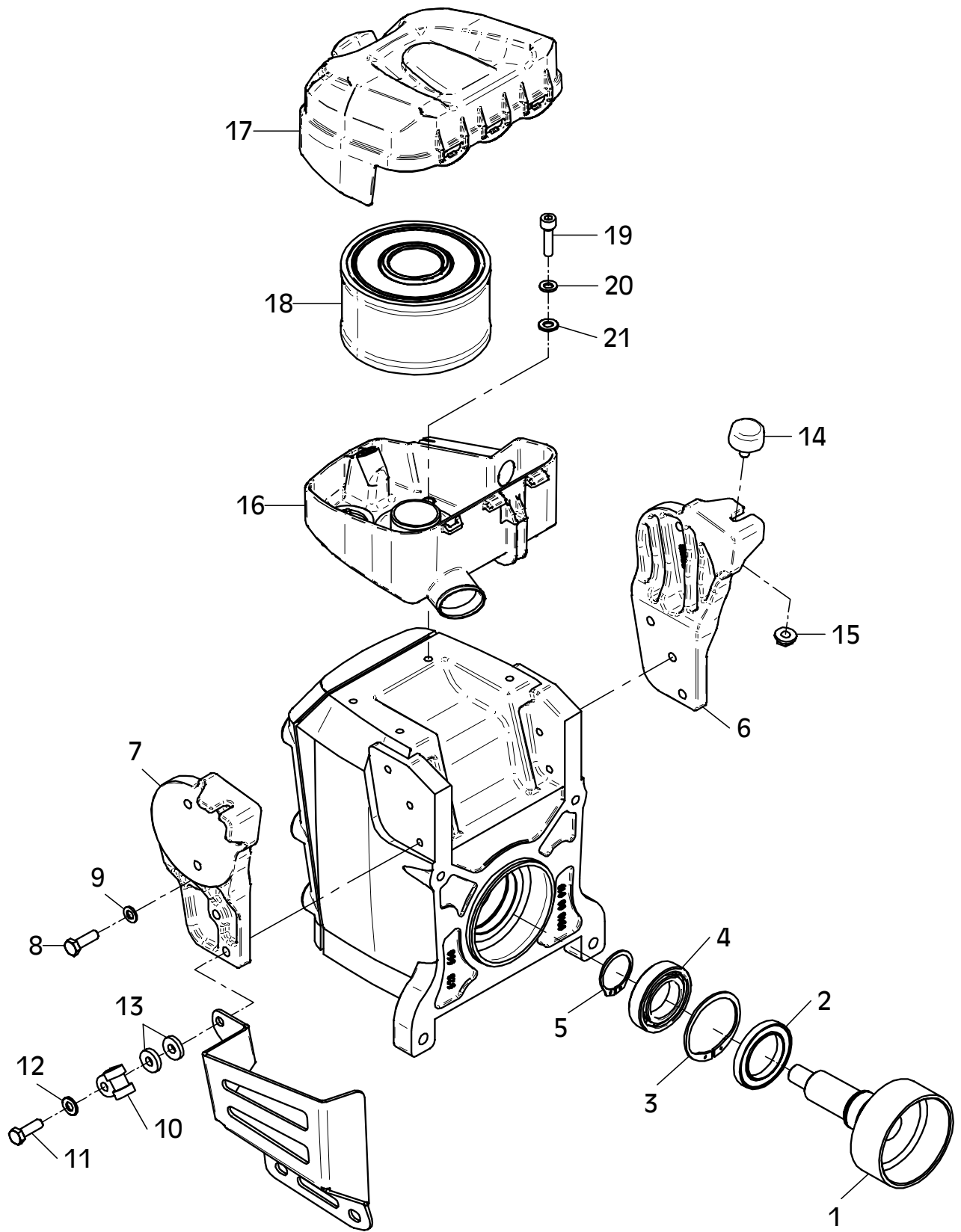

E 3463-0612

Position Ref.No. Repère Posizione Posicion	Menge Quantity Quantité Quantita Cantidad	Teile-Nr. Part-No. No. Référence Nr. d'Ordine No. Referenzia	Hinweis Hints Indications Indicazione Indicaciones	Position Ref. No. Repère Posizione Posicion	Menge Quantity Quantité Quantita Cantidad	Teile-Nr. Part-No. No. Référence Nr. d'Ordine No. Referenzia	Hinweis Hints Indications Indicazione Indicaciones
1	1	21000696					
2	1	21000710					
3	1	20022018	Tensilock M8x20				
4	1	25049016	DIN440-R9				
5	1	11001237					
6	4	25044007	DIN912-M8x30				
7	4	20029003	VSK 8				
8	2	25038016	DIN933-M10x35				
9	2	25038017	DIN933-M10x40				
10	4	20029001	VSK 10				
11	1	11001259					
12	4	25038007	DIN933-M8x20				
13	2	25038006	DIN933-M8x16				
14	6	20029031	SKM 8				
15	1	11001260					
16	2	25038006	DIN933-M8x16				
17	2	20029031	SKM 8				
18	1	21000668					
19	1	21000360	DIN6799-5				
20							
21	1	41001125					
22	1	21000487					

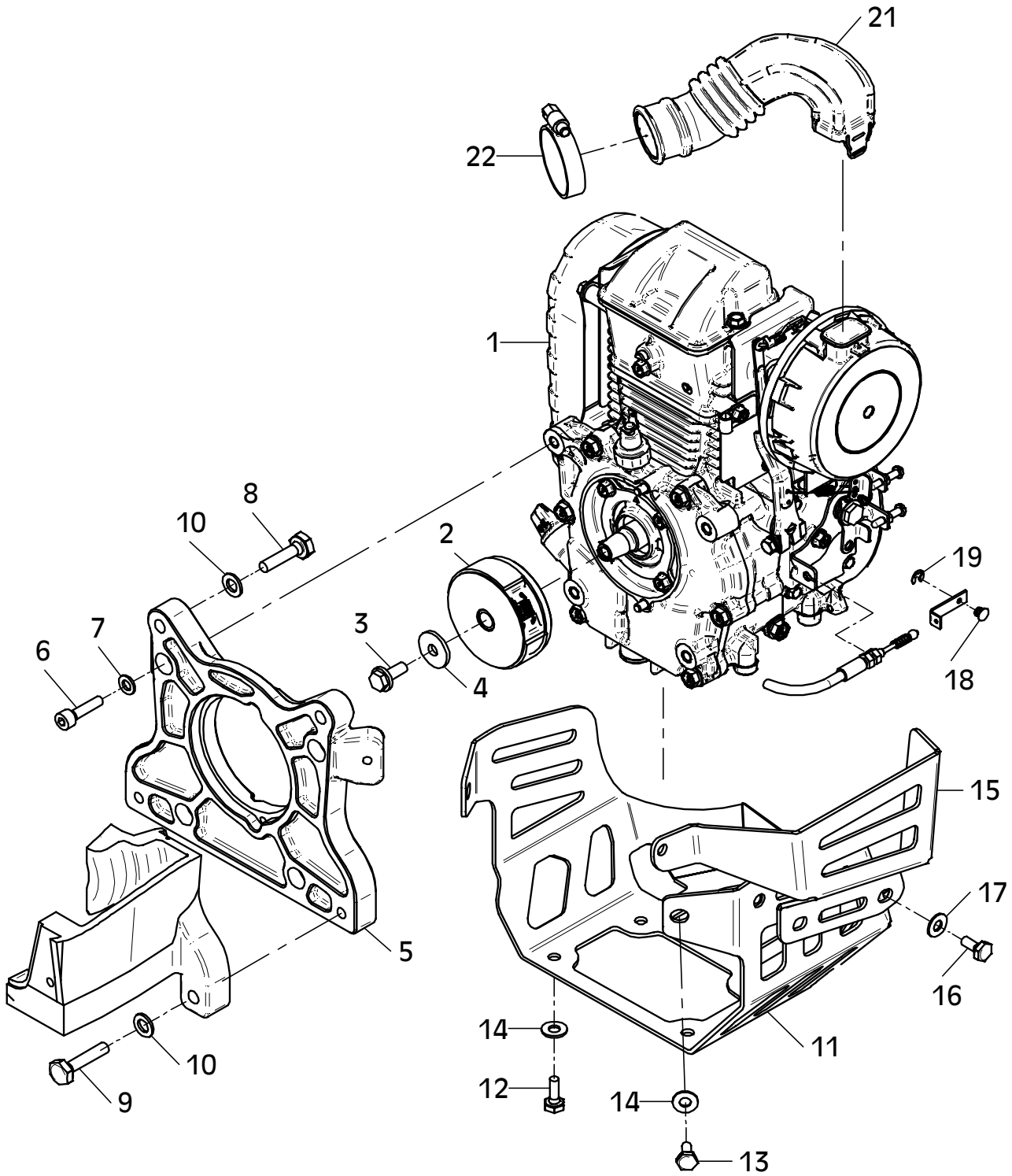

E 3464-0312

Position Ref.No. Repère Posizione Posicion	Menge Quantity Quantité Quantita Cantidad	Teile-Nr. Part-No. No. Référence Nr. d'Ordine No. Referenzia	Hinweis Hints Indications Indicazione Indicaciones	Position Ref. No. Repère Posizione Posicion	Menge Quantity Quantité Quantita Cantidad	Teile-Nr. Part-No. No. Référence Nr. d'Ordine No. Referenzia	Hinweis Hints Indications Indicazione Indicaciones
1	1	21000710					
2	2	21000525					
3	4	20002232					

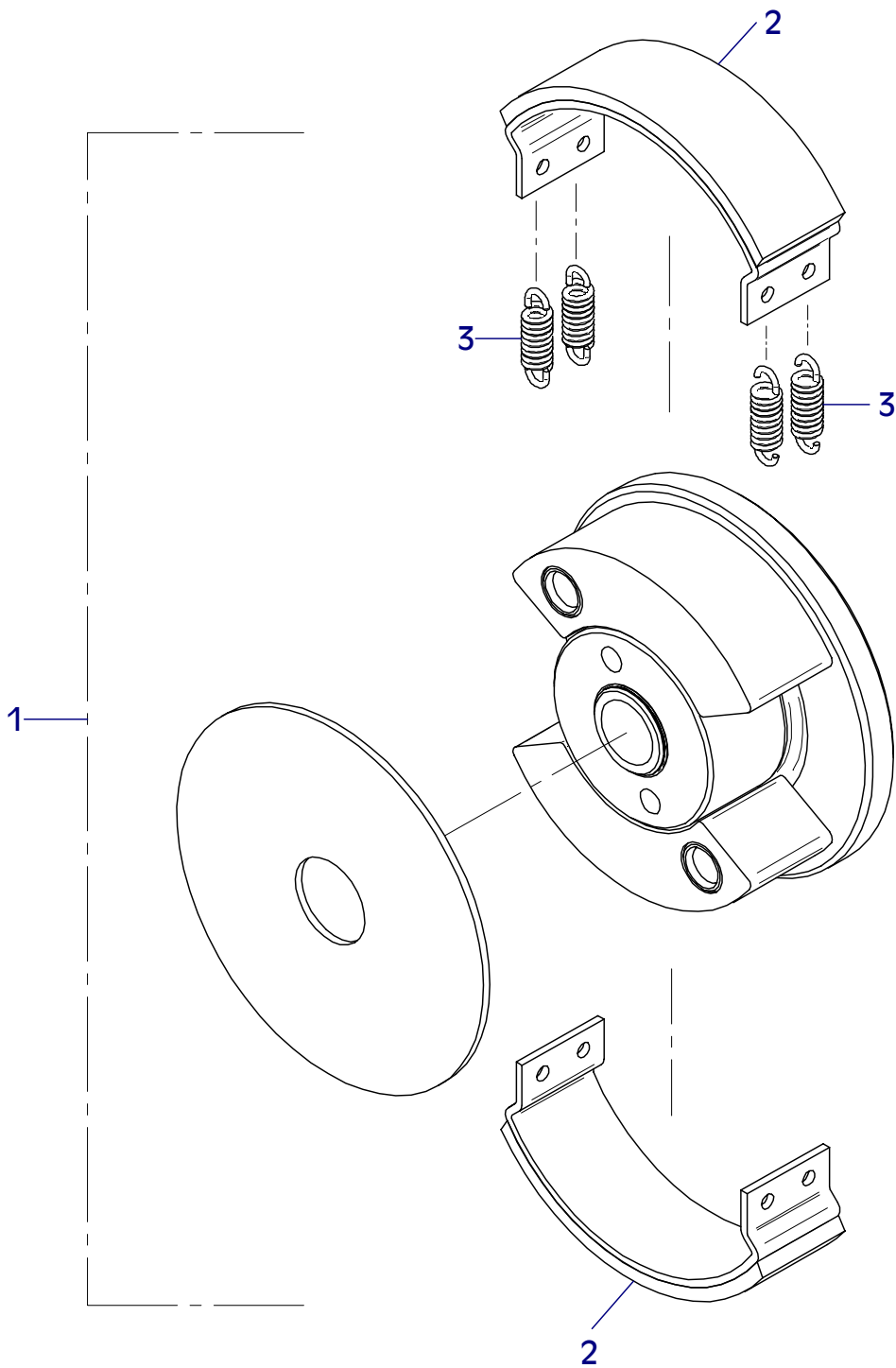

E 3464-0312

E 3465-0312

Position Ref.No. Repère Posizione Posicion	Menge Quantity Quantité Quantità Cantidad	Teile-Nr. Part-No. No. Référence Nr. d'Ordine No. Referenzia	Hinweis Hints Indications Indicazione Indicaciones	Position Ref. No. Repère Posizione Posicion	Menge Quantity Quantité Quantità Cantidad	Teile-Nr. Part-No. No. Référence Nr. d'Ordine No. Referenzia	Hinweis Hints Indications Indicazione Indicaciones
1	1	11001081					
2	2	10017001					
3	2	11000504					
4	4	25044065	DIN912-M6x25				
5	4	25031012	DIN985-M6				
6	2	21000540					
7	8	25038007	DIN933-M8x20				
8	8	20029003	VSK 8				
9	1	21000708					
10	2	21000398	DIN7991-M5x10				
11	2	25005001	DIN6798-V5,1				
12	1	21000632					
13	1	25033030	ISO7380-M6x20-10.9				
14	1	25048001	DIN125-A6,4				
15	1	20022001	Tensilock M6				
16	1	21000632					
17	1	25033030	ISO7380-M6x20-10.9				
18	1	25048001	DIN125-A6,4				
19	1	20022001	Tensilock M6				
20	1	21000659					
21	1	11001004					

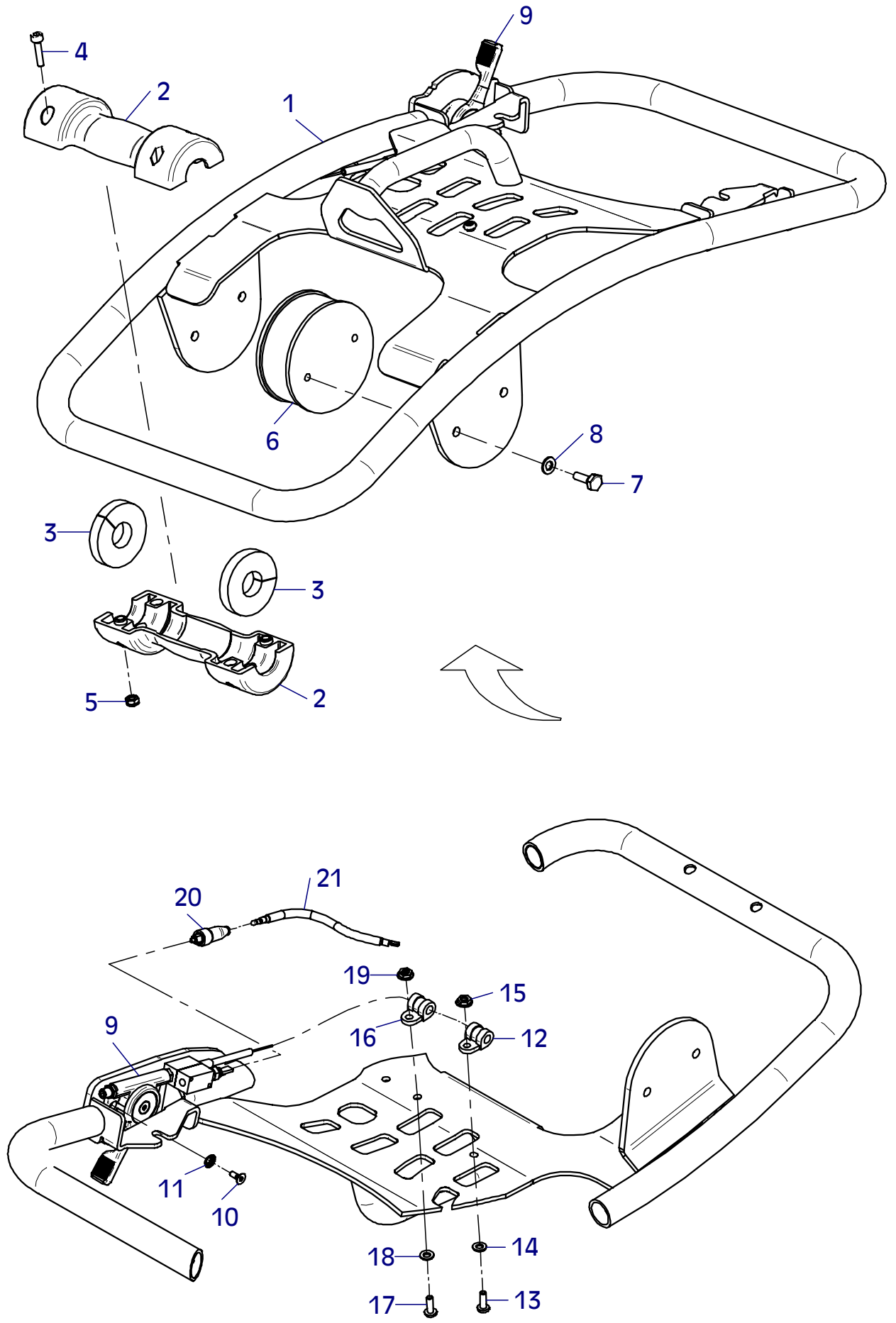

E 3465-0312

E 3466-0712

Position Ref.No. Repère Posizione Posicion	Menge Quantity Quantité Quantita Cantidad	Teile-Nr. Part-No. No. Référence Nr. d'Ordine No. Referenzia	Hinweis Hints Indications Indicazione Indicaciones	Position Ref. No. Repère Posizione Posicion	Menge Quantity Quantité Quantita Cantidad	Teile-Nr. Part-No. No. Référence Nr. d'Ordine No. Referenzia	Hinweis Hints Indications Indicazione Indicaciones
1	1	11001261					
2	2	25049026	DIN7349-8,4				
3	2	25031013	DIN985-M8				
4	1	11001262					
5	1	20026587					
6	1	20019423					
7	4	20026434					
8	1	20026588					
9	1	21000012					
10	1	20013072					
11	0	25025188	DIN988-PS-14x20x0,3				
12	1	20025612					
13	1	31000068	0,28m				
14	2	20007056					
15	1	31000068	0,04m				
16	1	20025634					

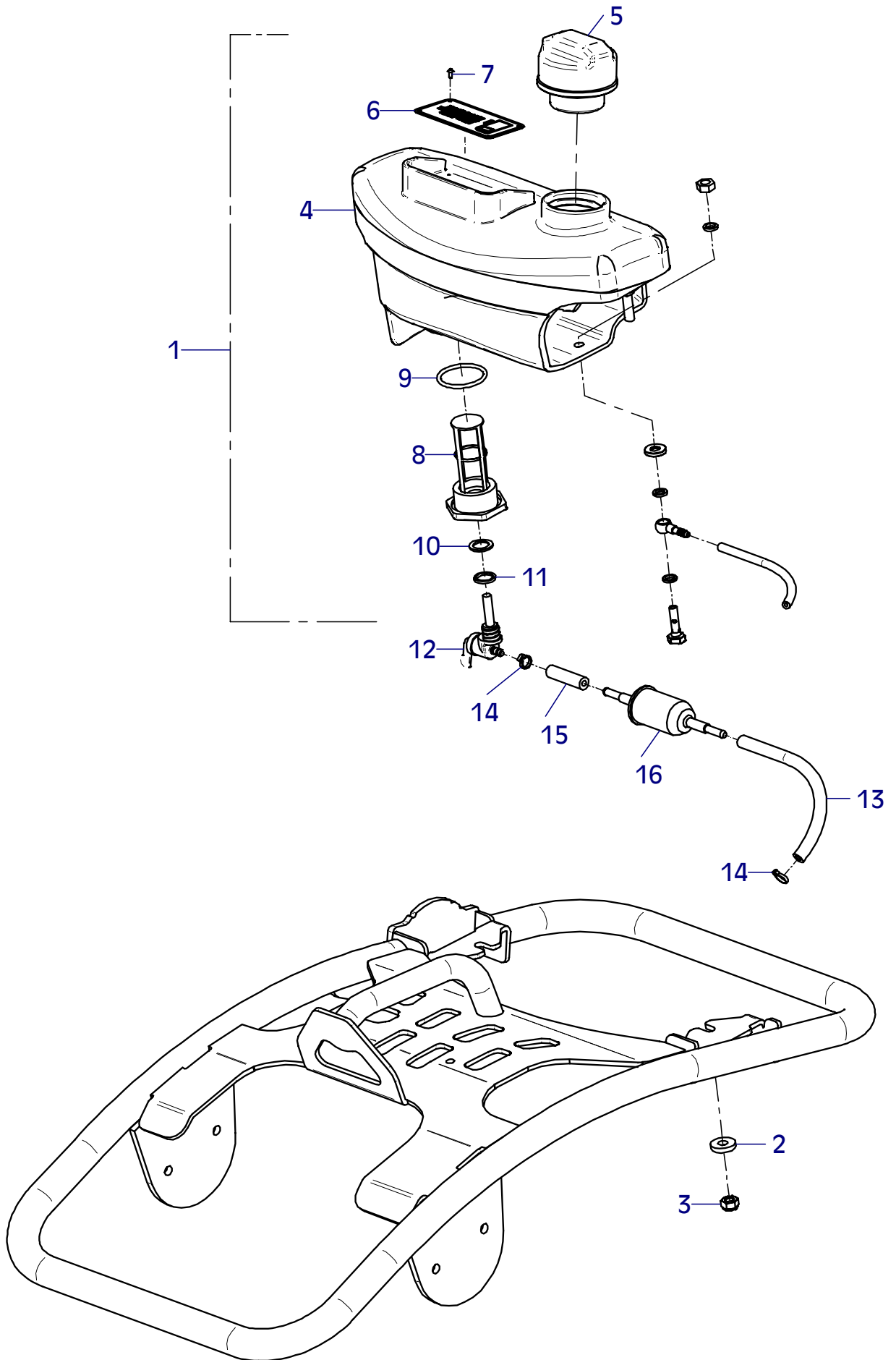

E 3466-0712

E 3400-0111

Position Ref.No. Repère Posizione Posicion	Menge Quantity Quantité Quantita Cantidad	Teile-Nr. Part-No. No. Référence Nr. d'Ordine No. Referenzia	Hinweis Hints Indications Indicazione Indicaciones	Position Ref. No. Repère Posizione Posicion	Menge Quantity Quantité Quantita Cantidad	Teile-Nr. Part-No. No. Référence Nr. d'Ordine No. Referenzia	Hinweis Hints Indications Indicazione Indicaciones
1	1	11001085					
2	2	25033030	ISO7380-M6x20-10.9				
3	2	25048001	DIN125-A6,4				
4	2	25031012	DIN985-M6				
5	1	21000575					
6	2	21000584	DIN912-M4x12				
7	2	25048023	DIN125-B4,3				
8	2	25031011	DIN985-M4				

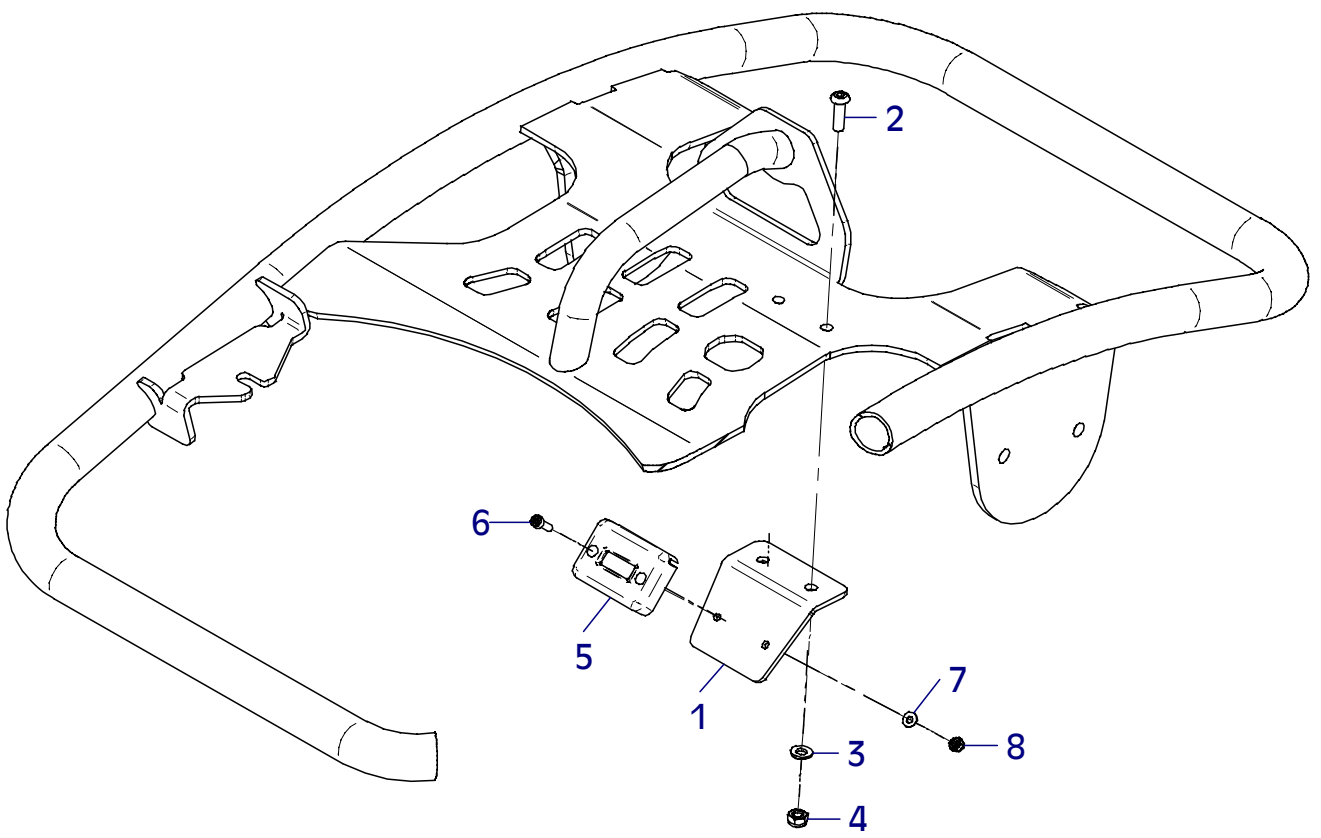

E 3414-0610

Position Ref.No. Repère Posizione Posicion	Menge Quantity Quantité Quantita Cantidad	Teile-Nr. Part-No. No. Référence Nr. d'Ordine No. Referenzia	Hinweis Hints Indications Indicazione Indicaciones	Position Ref. No. Repère Posizione Posicion	Menge Quantity Quantité Quantita Cantidad	Teile-Nr. Part-No. No. Référence Nr. d'Ordine No. Referenzia	Hinweis Hints Indications Indicazione Indicaciones
1	1	11000986					

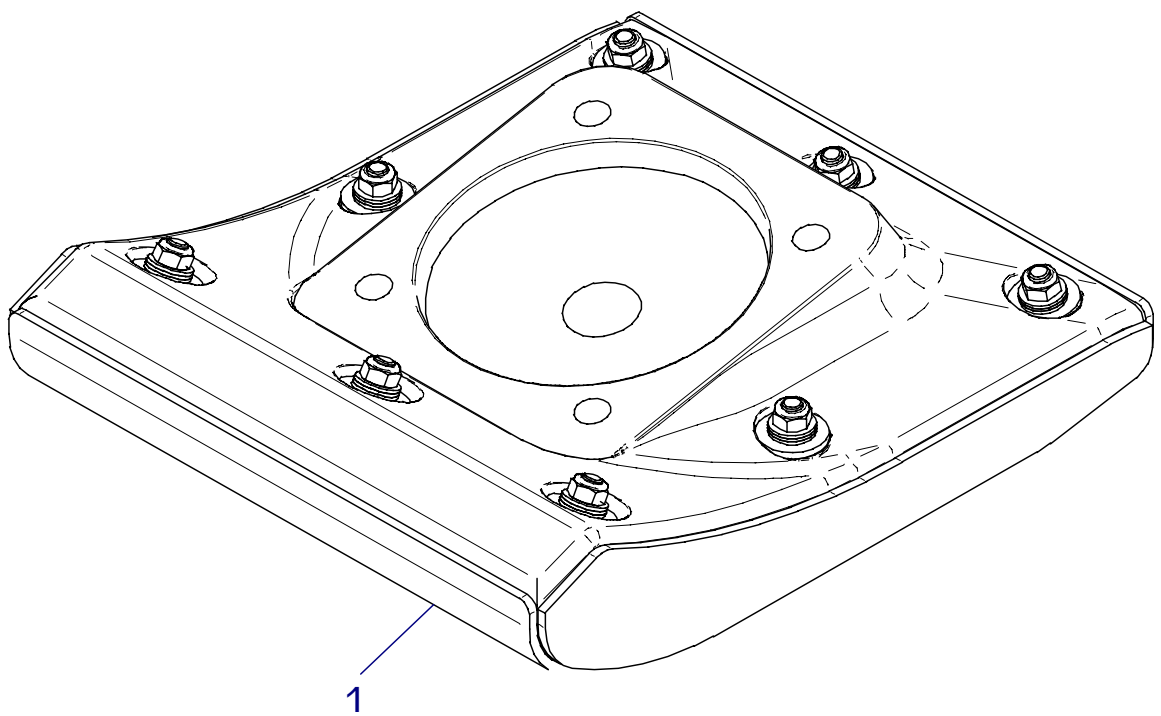

1

E 3414-0610

E 3426-0211

Position Ref.No. Repère Posizione Posicion	Menge Quantity Quantité Quantita Cantidad	Teile-Nr. Part-No. No. Référence Nr. d'Ordine No. Referenzia	Hinweis Hints Indications Indicazione Indicaciones	Position Ref. No. Repère Posizione Posicion	Menge Quantity Quantité Quantita Cantidad	Teile-Nr. Part-No. No. Référence Nr. d'Ordine No. Referenzia	Hinweis Hints Indications Indicazione Indicaciones
1	1	11001074					
2	1	11001080					
3	2	25038059	DIN933-M12x65				
4	2	25040033	DIN931-M12x70				
5	4	25048004	DIN125-A13				
6	4	25049027	DIN435-DM14				
7	4	25031015	DIN985-M12				

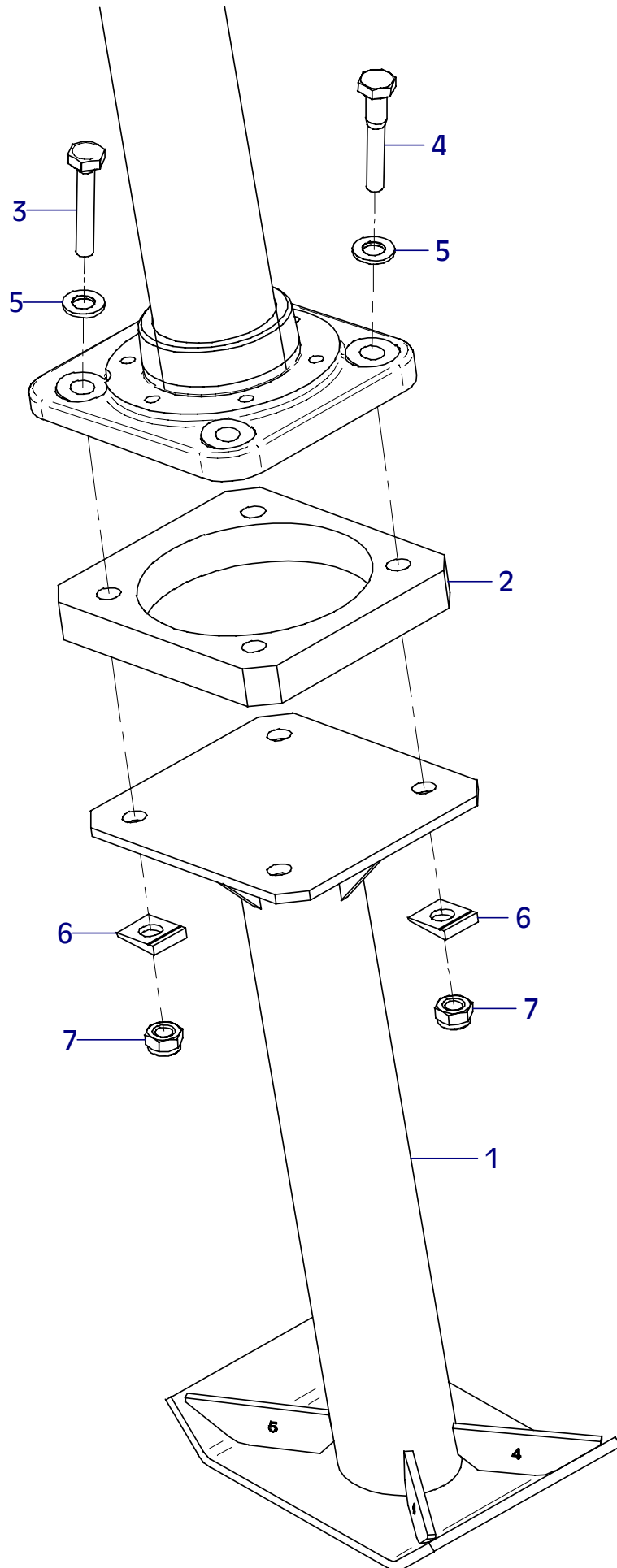

E 3426-0211

Wenn Sie Fragen, Anregungen, Probleme, usw. haben, wenden Sie sich bitte an eine der unten genannten Adressen:

For problems, questions and further information refer to one of the following addresses:

Si des questions, des suggestions, des problèmes ... survenaient, veuillez vous adresser a l'une des adresses - ci dessous

<p>in Deutschland</p> <p>in Germany</p> <p>Pour l' Allemagne</p>	<p>WEBER Maschinentechnik GmbH 57334 Bad Laasphe – Rückershausen Im Boden 5-8, 10</p>	<p>Telefon + 49 (0) 2754 - 398-0 Telefax + 49 (0) 2754 - 398101- Zentrale switchboard Central + 49 (0) 2754 - 398102- Ersatzteil-Direktlinie spare parts-directlinie Ligne direct pièces détachées</p> <p>E-Mail g.voelkel@webermt.de</p>
<p>in Frankreich</p> <p>in France</p> <p>Pour la France</p>	<p>WEBER Technologie SARL 26' rue d' Arsonval 69680 Chassieu</p>	<p>Telefon + 33 (0) 472 - 791020 Telefax + 33 (0) 472 - 791021</p> <p>E-Mail france@webermt.com</p>
<p>in Polen</p> <p>in Poland</p> <p>Pour la Pologne</p>	<p>WEBER Maschinentechnik Sp. zo.o. Ul. Grodziska 7 05-830 Stara Wies</p>	<p>Telefon + 48 (0) 22 - 739 70 - 80 Telefax + 48 (0) 22 - 739 70 - 81 + 48 (0) 22 - 739 70 - 82</p> <p>E-Mail info@webermt.com.pl</p>
<p>in USA und Kanada</p> <p>in USA and Canada</p> <p>Pour les Etats Unis Et le Canada</p>	<p>WEBER MT, Inc. 45 Dowd Road Bangor, ME 04401</p>	<p>Telefon + 1(207) - 947 - 4990 Telefax + 1(207) - 947 - 5452</p> <p>E-Mail sales@webermt.com service@webermt.com</p>
<p>in Süd – Amerika</p> <p>in South – America</p> <p>Pour l' Amérique du sud</p>	<p>WEBER Maschinentechnik do Brasil Máquinas Para Construção Ltda. Rua Curt Wacker, n° 45 93332 – 200 Novo Hamburgo, RS Brasil</p>	<p>Telefon + 55 (0) 51- 587 3044 Telefax + 55 (0) 51- 587 2271</p> <p>E-Mail webermt@webermt.com.br</p>

