

SRV 66

0170411 - 0170412

Ab Masch.-Nr.



Spare parts
Spares
Piezas de recambio
Ricambi
Peças de reposição
Pieșe de schimb
Náhradných dielov
Reservedele
Części zamienne



Weber Maschinenteknik GmbH
D- 57334 Bad Laasphe / Germany
Tel. +49 (0) 2754 / 398-0
Fax. +49 (0) 2754 / 398-101
E-Mail: info@webermt.de
www.webermt.com

BITTE, NOTIEREN SIE SERIENNUMMER UND MOTORNUMMER IHRER MASCHINE:

PLEASE WRITE DOWN SERIALNUMBERS OF MACHINE AND ENGINE:

NOTEZ SVP LE NUMERO DE SERIE ET LE NUMERO DU MOTEUR DE VOTRE MACHINE:

SI PREGA DI ANNOTARE SEMPRE I NUMERI DI SERIE SIA DELLA VS. MACCHINA CHE DEL MOTORE:

MAQUINA: ROGAMOS ANOTEN EL NUMERO DE SERIE Y NUMERO DE MOTOR DE SU MAQUINA:

MASCHINE
MACHINE
MACCHINA
MAQUINA

#

MOTOR
ENGINE
MOTEUR
MOTORE

#

ZUR VERMEIDUNG VON FEHLLIEFERUNGEN UND VERZÖGERUNGEN SIND BEI DER BESTELLUNG VON ERSATZTEILEN FOLGENDE ANGABEN UNBEDINGT ERFORDERLICH:

- MASCHINENTYP
- SERIENNUMMER DER MASCHINE
- SERIENNUMMER DES MOTORS (BEI MOTORTEILEN)
- TEILENUMMER
- BESTELLMENGE

TO AVOID ERRORS IN DELIVERY PLEASE STATE THESE PARTICULARS WHEN ORDERING:

- TYPE OF MACHINE
- SERIAL NO. OF MACHINE
- SERIAL NO. OF ENGINE (ON ENGINE PARTS)
- PART-NO.
- QUANTITY REQUIRED

AFIN D'EVITER DES ERREURS DE COMMANDE ET DES RETARDS DE LIVRAISON IL EST NECESSAIRE D'INDIQUER LES CARACTERISTIQUES SUIVANTES:

- TYPE DE MACHINE
- LE NUMERO DE SERIE DE LA MACHINE
- LE NUMERO DE SERIE DU MOTEUR
- LE NUMERO D'IDENTITE DE LA PIECE
- LA QUANTITE SOUHAITEE

ONDE EVITARE DISGUIDI E RITARDI NELLE CONSEGNE DIE RICAMBI SI PREGA DI INDICARE SEMPRE:

- TIPO DELLA MACCHINA
- NUMERO DI SERIE DELLA MACCHINA
- NUMERO DI SERIE DEL MOTORE (SE SI RICHIEDONO PEZZI DEL MOTORE)
- NUMERO D'ORDINE DIE SINGOLI RICAMBI
- QUANTITA

A FI DE EVITAR ERRORES DE ENTREGA, ROGAMOS INDIQUEN LOS SIGUIENTES DATOS CUANDO PASE PEDIDOS DE RECAMBIO:

- MODELO DE MAQUINA
- NO. DE SERIE DE LA MAQUINA
- NO. DE SERIE DEL MOTOR (EN PIEZAS PARA MOTOR)
- REFERENCIA DEL RECAMBIO
- CANTIDAD PEDIDA

E 3154-0604

Position Ref.No. Repère Posizione Posicion	Menge Quantity Quantité Quantita Cantidad	Teile-Nr. Part-No. No. Référence Nr. d'Ordine No. Referenzia	Hinweis Hints Indications Indicazione Indicaciones	Position Ref. No. Repère Posizione Posicion	Menge Quantity Quantité Quantita Cantidad	Teile-Nr. Part-No. No. Référence Nr. d'Ordine No. Referenzia	Hinweis Hints Indications Indicazione Indicaciones
1	1	10001478					
2	1	10017003					
3	2	25025247	DIN608-M12x90				
4	2	25025248	DIN608-M12x145				
5	12	20029032	SKM 12				
6	4	25031015	DIN985-M12				

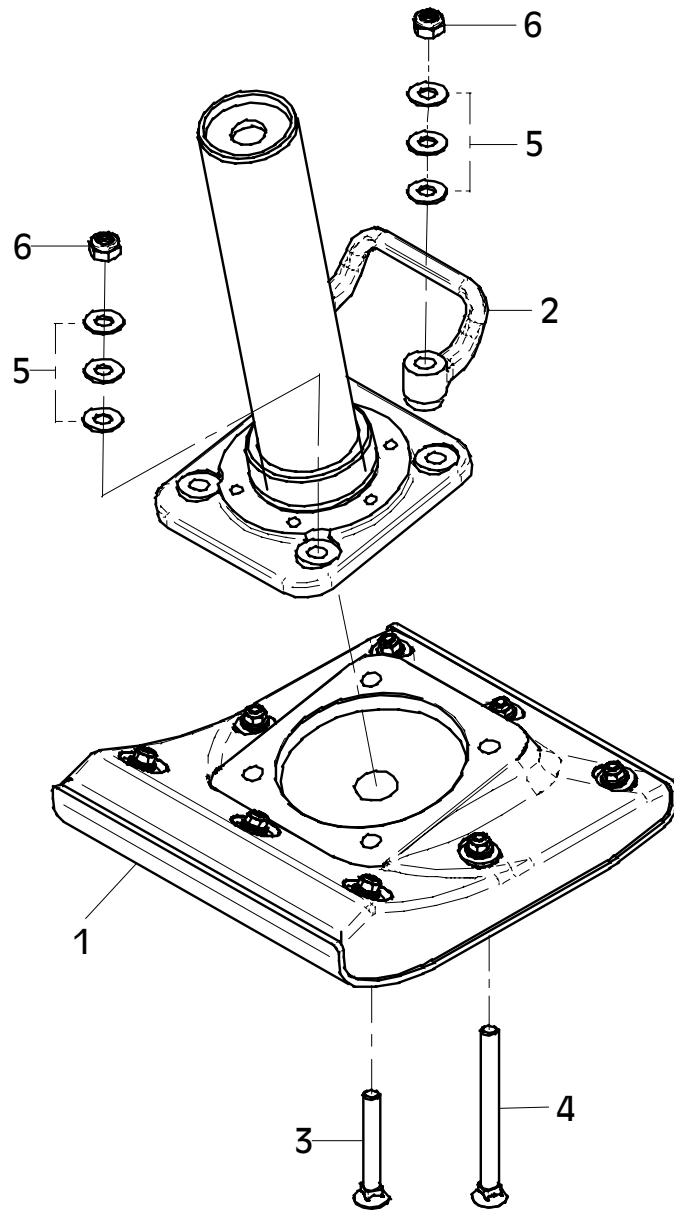

E 3154-0604

E 3160-0604

Position Ref.No. Repère Posizione Posicion	Menge Quantity Quantité Quantità Cantidad	Teile-Nr. Part-No. No. Référence Nr. d'Ordine No. Referenzia	Hinweis Hints Indications Indicazione Indicaciones	Position Ref. No. Repère Posizione Posicion	Menge Quantity Quantité Quantità Cantidad	Teile-Nr. Part-No. No. Référence Nr. d'Ordine No. Referenzia	Hinweis Hints Indications Indicazione Indicaciones
1	1	10016225					
2	4	25038016	DIN933-M10x35				
3	4	20029001	VSK 10				
4	1	10006970					
5	1	25025157					
6	1	10006969					
7	1	10006972					
8	2	10006971					
9	1	20025520					
9	1	21000073	Z				
10	2	20007039					
11	1	10006973					
12	1	25030014	DIN910-G1/2"				
13	1	25008007	DIN7603-21x26x1,5				
14	1	20013068					
15	1	10022193					
16	1	20013067					
17	1	11000334					
18	6	25038011	DIN933-M8x40				
19	6	20029003	VSK 8				
20	1	10022668					
21	1	10006965					
22	2	20008053					
23	2	20008035					

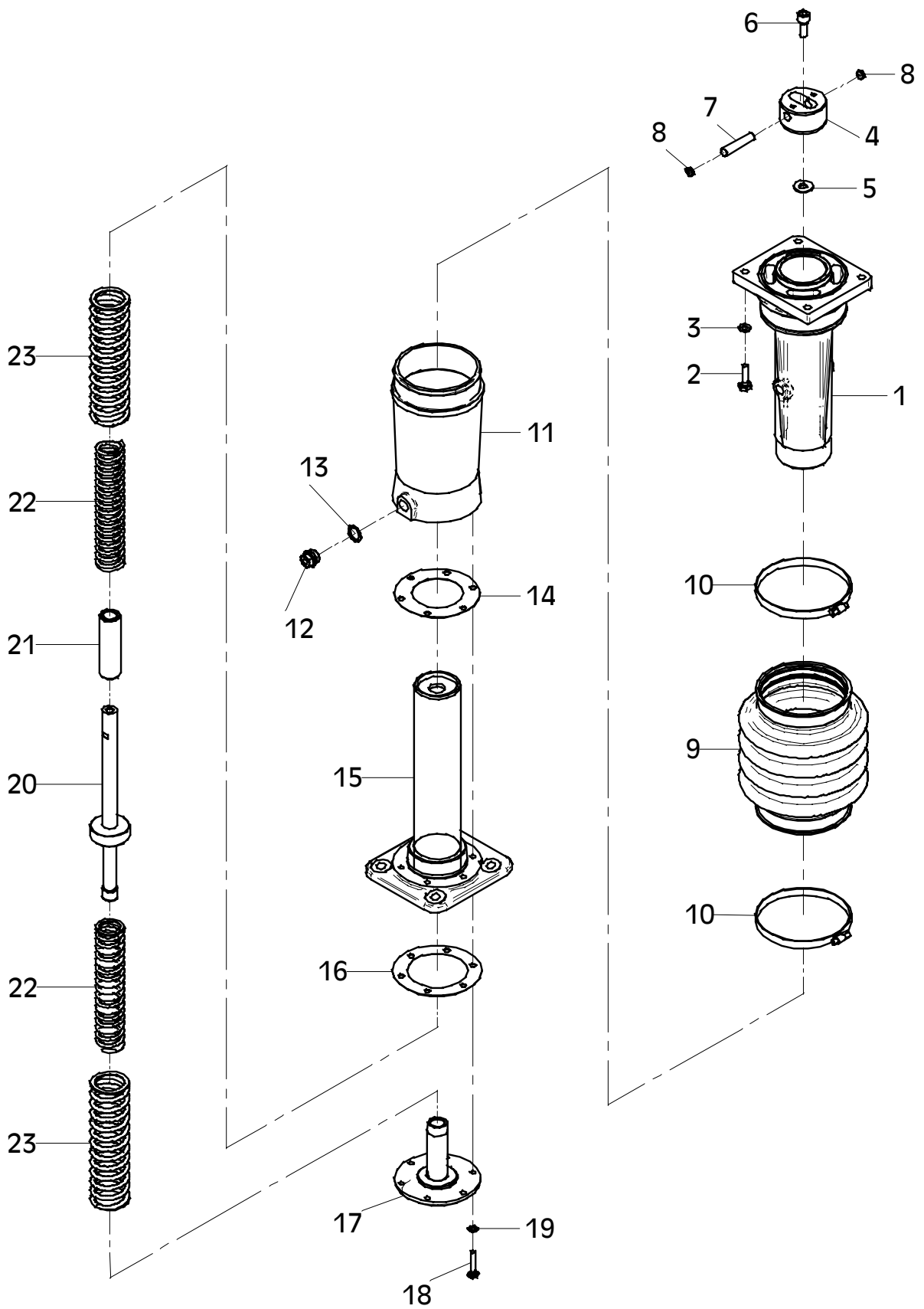

E 3161-0409

Position Ref.No. Repère Posizione Posicion	Menge Quantity Quantité Cantidad	Teile-Nr. Part-No. No. Référence Nr. d'Ordine No. Referenzia	Hinweis Hints Indications Indicazione Indicaciones	Position Ref. No. Repère Posizione Posicion	Menge Quantity Quantité Cantidad	Teile-Nr. Part-No. No. Référence Nr. d'Ordine No. Referenzia	Hinweis Hints Indications Indicazione Indicaciones
1	1	10015664		30	2	20029003	VSK 8
2	1	20025523		31	2	21000436	
3	4	20025521		32	2	20022002	Tensilock M8
4	1	20025524		33	1	10015666	
5	4	20025522		34	1	25017033	
6	2	20025522		35	1	25035003	DIN472-I62x2
7	1	11000333		36	1	25001045	
8	1	25035010	DIN472-I72x2,5	37	1	25034006	DIN471-A35x1,5
9	1	25001012		38	2	25049016	DIN440-R9
10	1	25034006	DIN471-A35x1,5	39	4	20029021	SKB 8
11	1	25001047		40	1	20007004	
12	1	25034016	DIN471-A25x1,2	41	1	25038012	DIN933-M8x45
13	1	10015665					
13	1	11000237	Z				
14	4	25044007	DIN912-M8x30				
15	4	20029003	VSK 8				
16	1	10007093					
17	1	25001257					
18	1	25035025	DIN472-I24x1,2				
19	1	10009653					
20	1	25025167					
21	1	25001206					
22	1	25034003	DIN471-A20x1,2				
23	1	25035008	DIN472-I42x1,75				
24	1	11000141					
25	1	10017311					
26	3	25038011	DIN933-M8x40				
27	4	25048002	DIN125-A8,4				
28	4	25031013	DIN985-M8				
29	2	25038007	DIN933-M8x20				

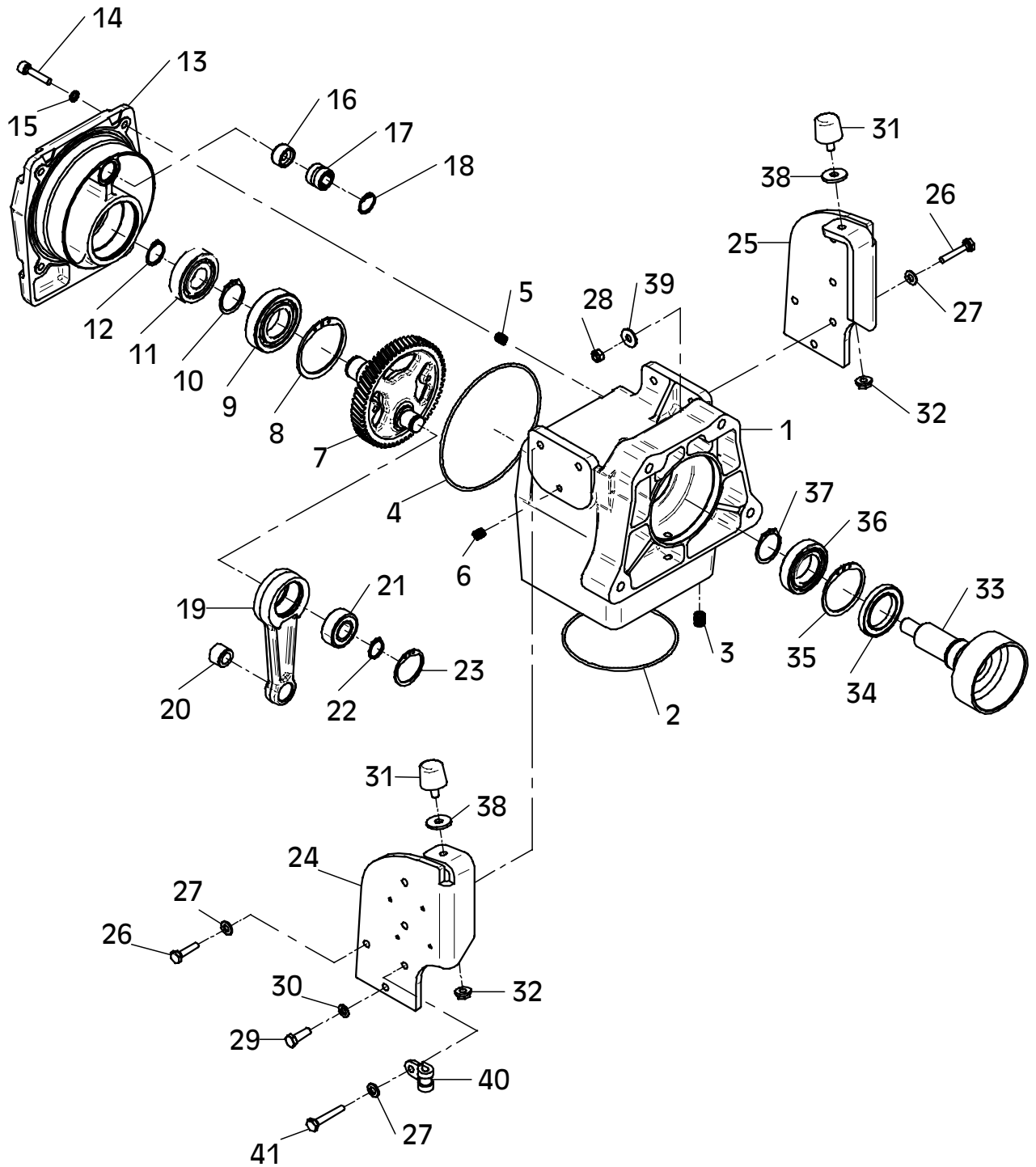

E 3162-0308

Position Ref.No. Repère Posizione Posicion	Menge Quantity Quantité Quantita Cantidad	Teile-Nr. Part-No. No. Référence Nr. d'Ordine No. Referenzia	Hinweis Hints Indications Indicazione Indicaciones	Position Ref. No. Repère Posizione Posicion	Menge Quantity Quantité Quantita Cantidad	Teile-Nr. Part-No. No. Référence Nr. d'Ordine No. Referenzia	Hinweis Hints Indications Indicazione Indicaciones
1	1	21000263					
2	4	25040014	DIN931-M10x65				
3	4	20029001	VSK 10				
4	1	20002074					
5	1	25049016	DIN440-R9				
6	1	20022018	Tensilock M8x20				
7	1	10015745					
8	2	25040027	DIN931-M8x35				
9	2	20022002	Tensilock M8				
10	1	25038007	DIN933-M8x20				
11	1	20029003	VSK 8				
12	1	25049016	DIN440-R9				
13	1	20007018					
14	1	25033039	DIN7981-C5,5x13				
15	1	11000140					
16	4	25038047	DIN933-M5x10				
17	4	20029006	VSK 5				
18	1	11000138					
19	1	21000030					
20	1	11000142					
21	1	21000034					
22	2	20007029					

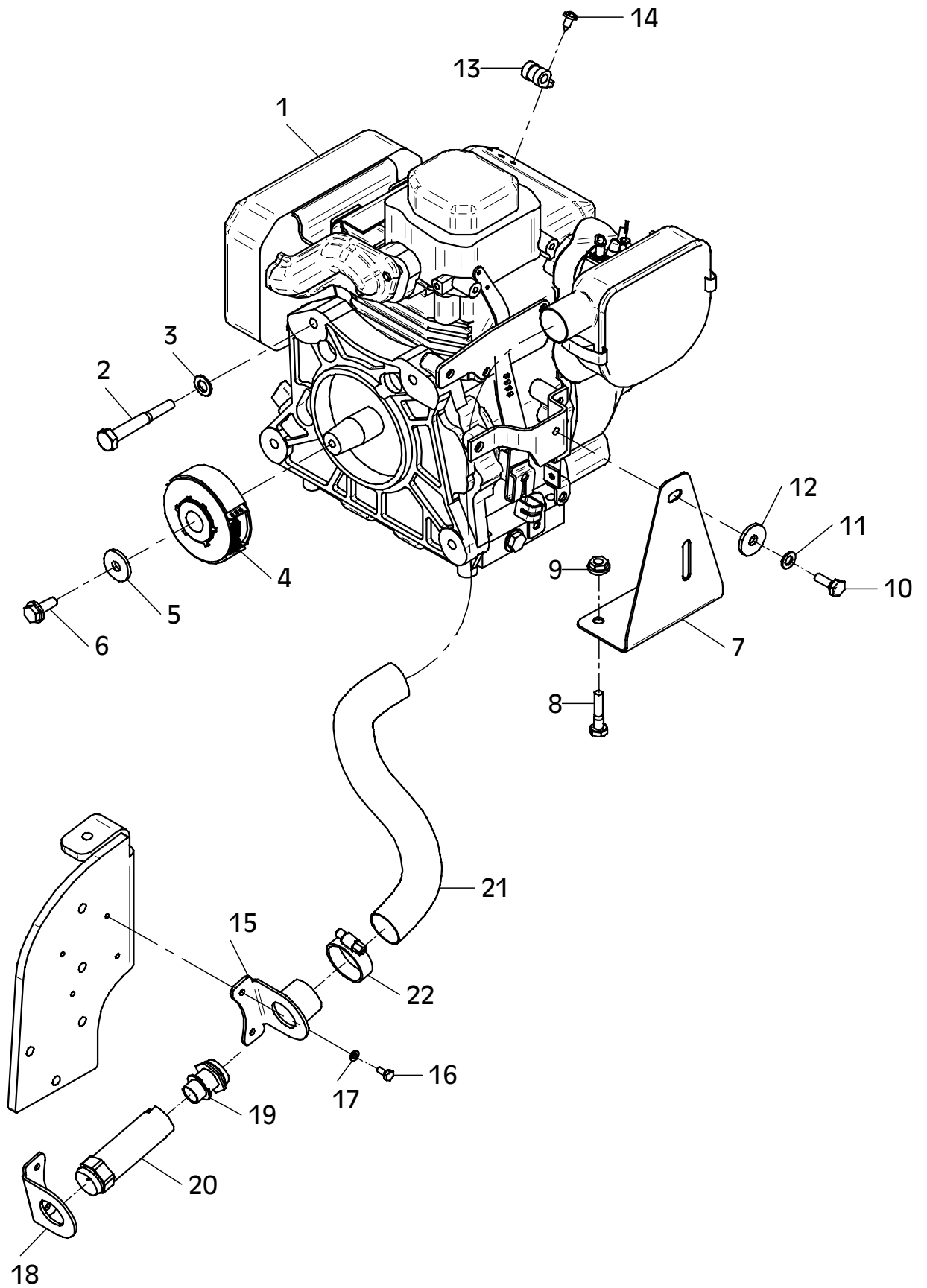

E 3162-0308

E 3163-0604

Position Ref.No. Repère Posizione Posicion	Menge Quantity Quantité Quantita Cantidad	Teile-Nr. Part-No. No. Référence Nr. d'Ordine No. Referenzia	Hinweis Hints Indications Indicazione Indicaciones	Position Ref. No. Repère Posizione Posicion	Menge Quantity Quantité Quantita Cantidad	Teile-Nr. Part-No. No. Référence Nr. d'Ordine No. Referenzia	Hinweis Hints Indications Indicazione Indicaciones
1	1	20002074					
2	2	20002254					
3	4	20002255					

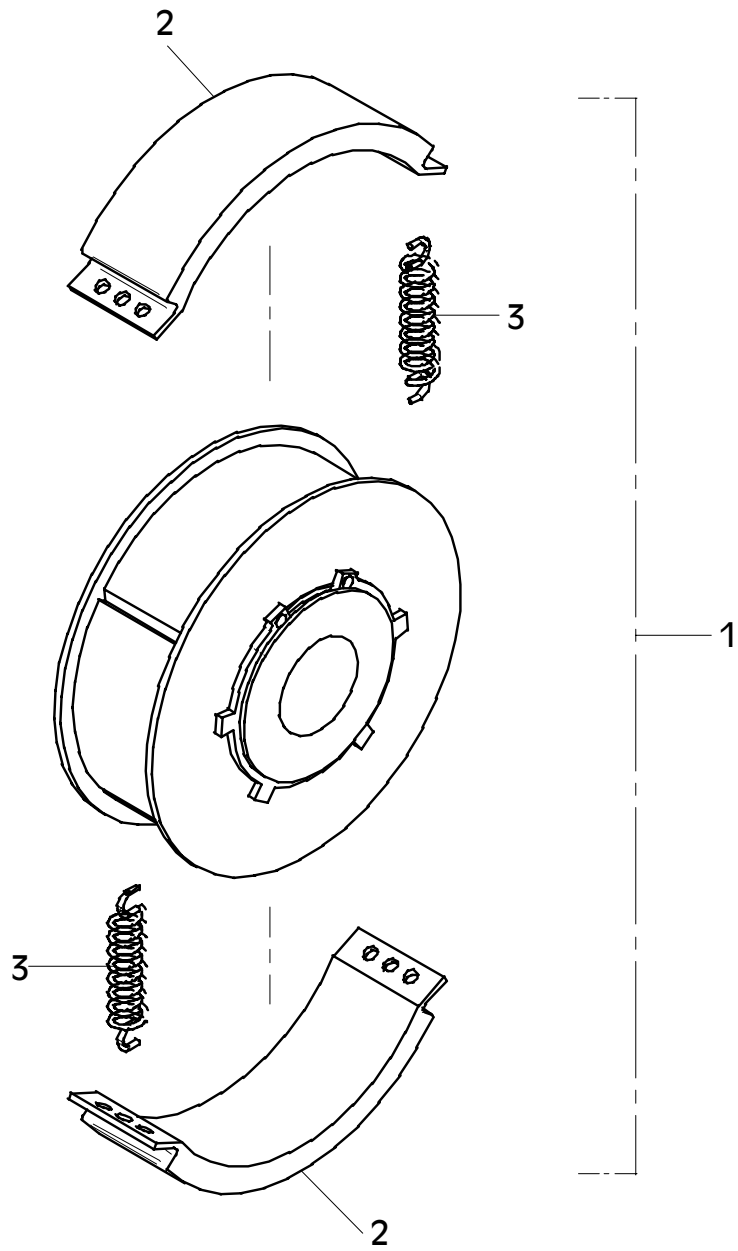

E 3163-0604

E 3164-0409

Position Ref.No. Repère Posizione Posicion	Menge Quantity Quantité Quantità Cantidad	Teile-Nr. Part-No. No. Référence Nr. d'Ordine No. Referenzia	Hinweis Hints Indications Indicazione Indicaciones	Position Ref. No. Repère Posizione Posicion	Menge Quantity Quantité Quantità Cantidad	Teile-Nr. Part-No. No. Référence Nr. d'Ordine No. Referenzia	Hinweis Hints Indications Indicazione Indicaciones
1	1	10022653		33	2	25031002	DIN934-M6
2	2	20004016		34	1	20008066	
3	8	25038007	DIN933-M8x20	35	1	25038003	DIN933-M6x20
4	8	20029003	VSK 8	36	1	25048001	DIN125-A6,4
5	1	25031002	DIN934-M6	37	2	20007007	
6				38	1	25048001	DIN125-A6,4
7				39	1	25033038	DIN1587-M6
8				40	1	25038002	DIN933-M6x16
9	2	10017327		41	1	25048001	DIN125-A6,4
10	4	25044065	DIN912-M6x25	42	1	20007007	
11	4	25031002	DIN934-M6	43	1	25048001	DIN125-A6,4
12	1	10017361		44	1	25033038	DIN1587-M6
12	1	11000343	Z	45	1	10001483	
13	2	25049026	DIN7349-8,4	46	1	40001767	
14	2	25031013	DIN985-M8	47	2	25033009	DIN85-M4x12
15	1	20026587		48	2	25048023	DIN125-B4,3
16	1	20019423		49	2	25033040	DIN1587-M4
17	4	20026434		50	1	10001484	
18	1	21000012		50	1	11000343	Z
19	1	20026588		51	2	11000504	
20	1	20013072					
21	0	25025188	DIN988-PS-14x20x0,3				
22	1	20025612					
23	1	11000317					
24	2	20007056					
28	1	20025791					
29	2	25047001	DIN7991-M5x12				
30	2	20029006	VSK 5				
31	2	25033037	DIN1587-M5				
32	1	20006422					

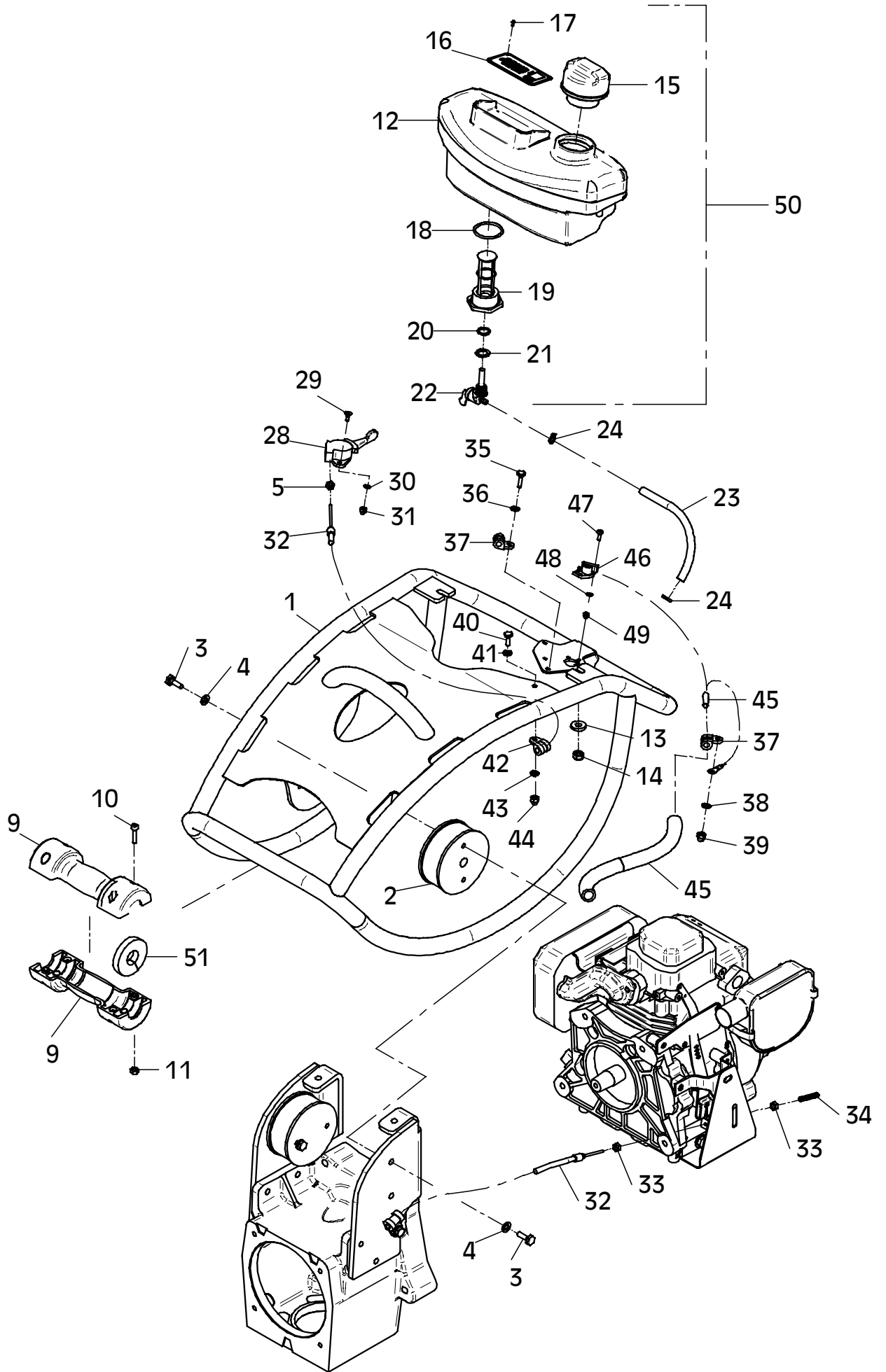

E 3164-0409

Wenn Sie Fragen, Anregungen, Probleme, usw. haben, wenden Sie sich bitte an eine der unten genannten Adressen:

For problems, questions and further information refer to one of the following addresses:

Si des questions, des suggestions, des problèmes ... survenaient, veuillez vous adresser a l'une des adresses - ci dessous

<p>in Deutschland</p> <p>in Germany</p> <p>Pour l' Allemagne</p>	<p>WEBER Maschinentechnik GmbH 57334 Bad Laasphe – Rückershausen Im Boden 5-8, 10</p>	<p>Telefon + 49 (0) 2754 - 398-0 Telefax + 49 (0) 2754 - 398101-Zentrale switchboard Central + 49 (0) 2754 - 398102-Ersatzteil-Direktlinie spare parts-directlinie Ligne direct pièces détachées</p> <p>E-Mail g.voelkel@webermt.de</p>
<p>in Frankreich</p> <p>in France</p> <p>Pour la France</p>	<p>WEBER Technologie SARL 26' rue d' Arsonval 69680 Chassieu</p>	<p>Telefon + 33 (0) 472 -791020 Telefax + 33 (0) 472 – 791021</p> <p>E-Mail france@webermt.com</p>
<p>in Polen</p> <p>in Poland</p> <p>Pour la Pologne</p>	<p>WEBER Maschinentechnik Sp. zo.o. Ul. Grodziska 7 05-830 Stara Wies</p>	<p>Telefon + 48 (0) 22 - 739 70 - 80 Telefax + 48 (0) 22 - 739 70 - 81 + 48 (0) 22 - 739 70 - 82</p> <p>E-Mail info@webermt.com.pl</p>
<p>in USA und Kanada</p> <p>in USA and Canada</p> <p>Pour les Etats Unis Et le Canada</p>	<p>WEBER MT, Inc. 45 Dowd Road Bangor, ME 04401</p>	<p>Telefon + 1(207) - 947 - 4990 Telefax + 1(207) - 947 – 5452</p> <p>E-Mail usa@webermt.com</p>
<p>in Süd – Amerika</p> <p>in South – America</p> <p>Pour l' Amérique du sud</p>	<p>WEBER Maschinentechnik do Brasil Máquinas Para Construção Ltda. Rua Curt Wacker, n° 45 93332 – 200 Novo Hamburgo, RS Brasil</p>	<p>Telefon + 55 (0) 51- 587 3044 Telefax + 55 (0) 51- 587 2271</p> <p>E-Mail webermt@webermt.com.br</p>

