



ERSATZTEILLISTE

SPARE PARTS LIST

**LISTE DES PIECES
DE RECHANGE**

LISTINO RICAMBI

LISTA DE RECAMBIOS

**WYKAZ CZESCI
ZAMIENNYCH**



SRX 65 R-3

Robin EC 12

000904

Weber Maschinenteknik GmbH
Postfach 2153, 57329 Bad Laasphe-Rückerhausen
Telefon 02754 / 398-0
Telefax (02754) 398-101 (Zentrale)
u. 398-102 (Ersatzteile)

EG - KONFORMITÄTSEKTLÄRUNG

EC DECLARATION OF CONFORMITY / DECLARATION DE CONFORMITE CE
DICHIARAZIONE CE DI CONFORMITA / DECLARACION CE DE CONFORMIDAD
EG-VERKLARING VAN OVEREENSTEMMING / EF-OVERENSSTEMMELSESEKTLÄRUNG
DECLARACAO CE DE CONFORMIDADE / EG-FÖRSÄKRAN OM ÖVERENSSTÄMMELSE
DEKLARACJA ZGODNOŚCI

im Sinne der EG-Maschinenrichtlinie 98/37/EG
und der EG Richtlinie 2000/14/EG - Geräuschemissionen

- I **Art / Category / Catégorie / Categoria Tipo / Kategori /**
Soort / Categoria / kategori / Typ
- II **Hersteller (Typ) / Make (Type) / Marque (Type) / Marca (Tipo) /**
Marca (Codice) / Producent (Type) / Merk (Type) / Marca (Tipo) /
Tillverkare (Typ) / Producent
- III **Nennleistung / Nominal-performance / La puissance nominale / Prestazione nominale /**
Potencia nominal / Nominaal vermogen / Nominel ydelse / Potência nominal / Nominell
effect / Moc
- IV **gemessener Schalleistungspegel / measured sound power level / niveau de**
puissance acoustique mesure / livello di potenza sonora rilevato / nivel de potencia
acústica medido / gemeten geluidsvermogensniveau / målt lydeffektniveau / Nivel de
potência sonora midido / uppmätt ljudeffektnivå / Mierzony poziom dźwięku
- V **garantierter Schalleistungspegel / guaranteed sound power level / niveau de**
puissance acoustique garanti / livello di potenza sonora garantito / nivel de potencia
acustica garantizado / gewaarborgd geluidsvermogensniveau / garanteret lydeffektniveau /
Nivel sonoro garantido / garanterad ljudeffektniva / Natężenie hałas
- VI **beteiligte Zertifizierungsstelle / notified body involved / de l'organisme notifié /**
dell'organismo notificato che l'ha effettuata / dirección del organismo notificado que haya
intervenido / betrokken aangemelde instantie / pagældende bemyndigede organ /
organismo notificado envolvido / berörda anmälda organets namn / Jednostka
certyfikująca
- VII **Konformitäts-Bewertungsverfahren / Conformity assessment procedure followed /**
la procédure appliquée pour l'évaluation de la conformité et / procedura di valutazione
della conformità / procedimiento de evaluación de la conformidad / gevolgd
overeenstemmingsbeoordelingsprocedure / den fulgte
overensstemmelsesvurderingsprocedure / procedimento de avaliacao de conformidade
/ Vilket förfarande för bedömning av överensstämmelse / Przebieg kontroli

Vibrationsstamper
SRX65



P = 2,3 kW

LWA = 107 dB (A)

LWA = 108 dB (A)

RWTÜV
Postfach 103161
D-45032 Essen

interne Fertigungskontrolle
nach Anhang VI
EG Richtlinie 2000/14/EG

ist in Übereinstimmung mit folgenden Richtlinien hergestellt worden / has been produced in accordance with following standards / est produit conforme aux dispositions des directives européennes ci-apres / ha sido fabricado en conformidad con las siguientes normas / é stato fabbricato in conformità alle seguenti norme / er blevet fremstillet i overensstemmelse med følgende retningslinier / in overeenstemming met de volgende voorschriften gefabriceerd is / é fabricado conforme as seguintes normas / har tillverkats i överensstämmelse med följande riktlinjer / Zgodność z obowiązującymi przepisami

98/37/EG Maschinenrichtlinie des europäischen Parlamentes und des Rates vom 22. Juni 1998
2000/14/EG EG-Richtlinie Geräuschemissionen vom 8. Mai 2000
EN 500 Teil 1 Bewegliche Straßenbaumaschinen – Sicherheit
Gemeinsame Anforderungen
EN 500 Teil 4 Bewegliche Straßenbaumaschinen – Sicherheit
Besondere Anforderungen an Verdichtungsmaschinen

Bescheinigung bitte sorgfältig aufbewahren / File certificate carefully / Conserver certificat soigneusement / Conservar
certificado cuidadosamente / Pregasi conservare accuratamente certificato / Beviset bedes opbevares omhyggeligt / Verklaring a.u.b.
zorgvuldig bevar / Conservar o certificado com cuidado / Beviset skall om sorgsfullt bevaras // Deklarację zgodności proszę zachować

Bad Laasphe – Rückershausen, den 02.01.2003

W. Weber, Geschäftsführer

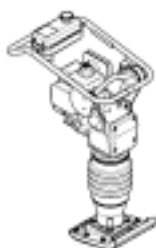

WEBER Maschinentchnik GmbH
Im Boden 5-8, 10 – D-57334 Bad Laasphe
Postfach 2153 – D-57329 Bad Laasphe
Telefon: 02754/398-0 – Fax 02754/398-101
E-mail: Verkauf@webermt.de
Internet: <http://www.webermt.de>



BITTE, NOTIEREN SIE SERIENNUMMER UND MOTORNUMMER IHRER MASCHINE:

PLEASE WRITE DOWN SERIALNUMBERS OF MACHINE AND ENGINE:

NOTEZ SVP LE NUMERO DE SERIE ET LE NUMERO DU MOTEUR DE VOTRE MACHINE:

SI PREGA DI ANNOTARE SEMPRE I NUMERI DI SERIE SIA DELLA VS. MACCHINA CHE DEL MOTORE:

MAQUINA: ROGAMOS ANOTEN EL NUMERO DE SERIE Y NUMERO DE MOTOR DE SU MAQUINA:

MASCHINE
MACHINE
MACCHINA
MAQUINA

#

MOTOR
ENGINE
MOTEUR
MOTORE

#

ZUR VERMEIDUNG VON FEHLLIEFERUNGEN UND VERZÖGERUNGEN SIND BEI DER BESTELLUNG VON ERSATZTEILEN FOLGENDE ANGABEN UNBEDINGT ERFORDERLICH:

- MASCHINENTYP
- SERIENNUMMER DER MASCHINE
- SERIENNUMMER DES MOTORS (BEI MOTORTEILEN)
- TEILENUMMER
- BESTELLMENGE

TO AVOID ERRORS IN DELIVERY PLEASE STATE THESE PARTICULARS WHEN ORDERING:

- TYPE OF MACHINE
- SERIAL NO. OF MACHINE
- SERIAL NO. OF ENGINE (ON ENGINE PARTS)
- PART-NO.
- QUANTITY REQUIRED

AFIN D'EVITER DES ERREURS DE COMMANDE ET DES RETARDS DE LIVRAISON IL EST NECESSAIRE D'INDIQUER LES CARACTERISTIQUES SUIVANTES:

- TYPE DE MACHINE
- LE NUMERO DE SERIE DE LA MACHINE
- LE NUMERO DE SERIE DU MOTEUR
- LE NUMERO D'IDENTITE DE LA PIECE
- LA QUANTITE SOUHAITEE

ONDE EVITARE DISGUIDI E RITARDI NELLE CONSEGNE DIE RICAMBI SI PREGA DI INDICARE SEMPRE:

- TIPO DELLA MACCHINA
- NUMERO DI SERIE DELLA MACCHINA
- NUMERO DI SERIE DEL MOTORE (SE SI RICHIEDONO PEZZI DEL MOTORE)
- NUMERO D'ORDINE DIE SINGOLI RICAMBI
- QUANTITA

A FI DE EVITAR ERRORES DE ENTREGA, ROGAMOS INDIQUEN LOS SIGUIENTES DATOS CUANDO PASE PEDIDOS DE RECAMBIO:

- MODELO DE MAQUINA
- NO. DE SERIE DE LA MAQUINA
- NO. DE SERIE DEL MOTOR (EN PIEZAS PARA MOTOR)
- REFERENCIA DEL RECAMBIO
- CANTIDAD PEDIDA

E756-0198

Position Ref.No. Repère Posizione Posicion	Menge Quantity Quantité Quantita Cantidad	Teile-Nr. Part-No. No. Référence Nr. d'Ordine No. Referenzia	Hinweis Hints Indications Indicazione Indicaciones	Position Ref. No. Repère Posizione Posicion	Menge Quantity Quantité Quantita Cantidad	Teile-Nr. Part-No. No. Référence Nr. d'Ordine No. Referenzia	Hinweis Hints Indications Indicazione Indicaciones
1	1	10006953					
2	1	20019005					
4	1	20025523					
5	1	10007153					
6	4	25044063	DIN 912-M8x35-8.8				
7	4	20029011	VSKZ 8				
8	1	20025524					
9	1	10007093					
10	1	25001257					
11	1	10009652					
12	1	25017033					
13	1	25035003	DIN 472-62x2				
14	1	25001045					
15	1	25034006	DIN 471-35x1,5				
16	1	25047003	DIN 7991-M8x16-8.8				
17	1	10005346					
18	1	25001047					
19	1	25034006	DIN 471-35x1,5				
20	1	25001012					
21	1	25035010	DIN 472-72x2,5				
22	1	10009651					
23	1	10009653					
24	1	25025167	DIN 179-A14x16				
25	1	25001206					
26	1	25034003	DIN 471-20x1,2				
27	1	25035008	DIN 472-42x1,75				

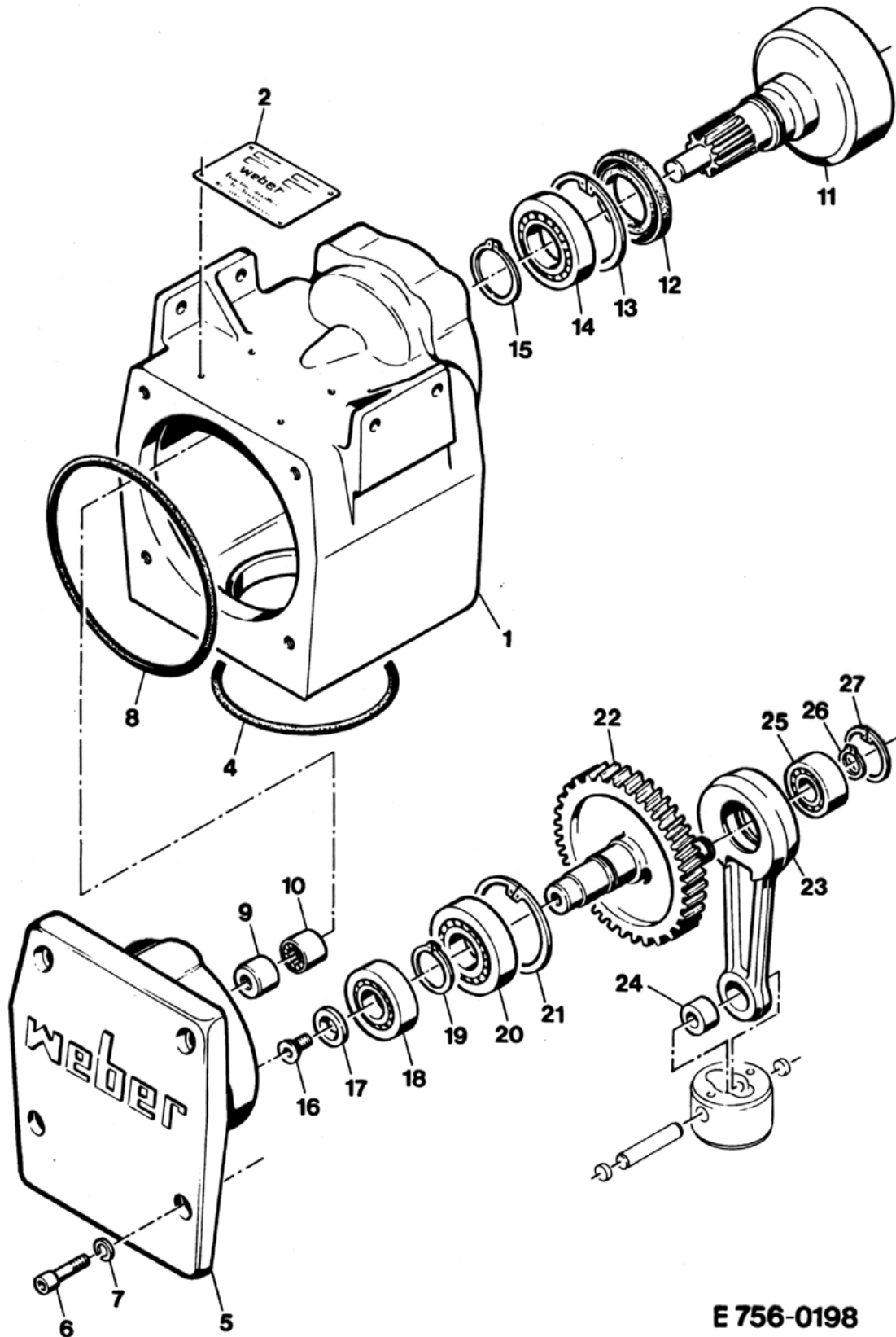

E 756-0198

E757-0695

Position Ref.No. Repère Posizione Posicion	Menge Quantity Quantité Quantita Cantidad	Teile-Nr. Part-No. No. Référence Nr. d'Ordine No. Referenzia	Hinweis Hints Indications Indicazione Indicaciones	Position Ref. No. Repère Posizione Posicion	Menge Quantity Quantité Quantita Cantidad	Teile-Nr. Part-No. No. Référence Nr. d'Ordine No. Referenzia	Hinweis Hints Indications Indicazione Indicaciones
1	1	10001162					
2	1	10006965					
3	2	20008036					
4	2	20008035					
5	1	10006964					
6	6	25038011	DIN 933-M8x40-8.8				
7	6	20029003	VSK 8				
8	1	20013067					
9	1	10022193					
10	1	20013068					
11	1	10006973					
12	1	25030014	DIN 910-G½A-5.8				
13	1	10006969					
14	1	10006970					
15	1	25025157	DIN 6796-12-FSt				
16	1	10006972					
17	2	10006971					
18	1	10007154					
19	4	25038016	DIN 933-M10x35-8.8				
20	4	20029001	VSK 10				
21	1	20025520					
22	2	20007039					
23	1	20013080					

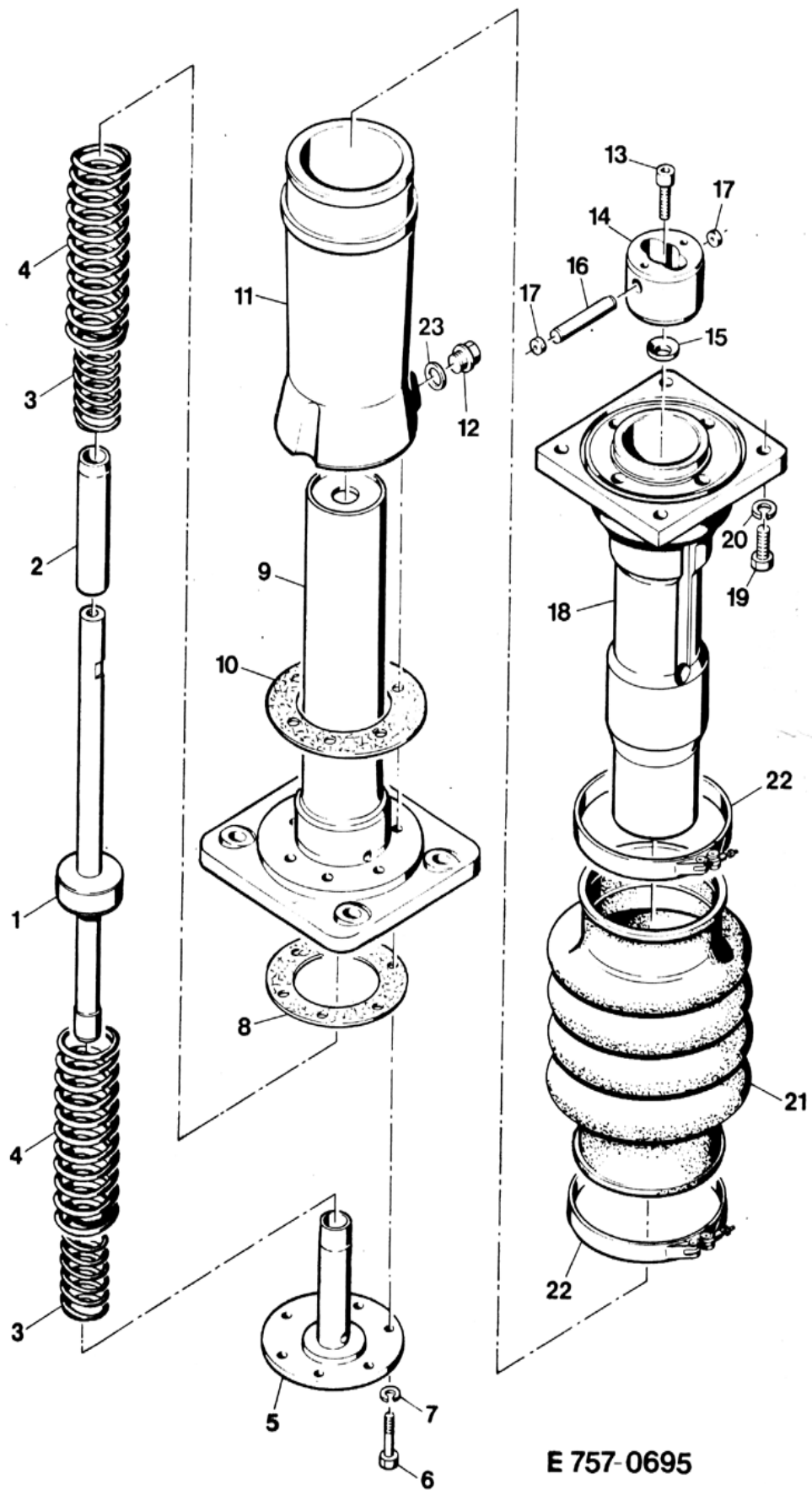

E 757-0695

E 551-0591

Position Ref.No. Repère Posizione Posicion	Menge Quantity Quantité Quantita Cantidad	Teile-Nr. Part-No. No. Référence Nr. d'Ordine No. Referenzia	Hinweis Hints Indications Indicazione Indicaciones	Position Ref. No. Repère Posizione Posicion	Menge Quantity Quantité Quantita Cantidad	Teile-Nr. Part-No. No. Référence Nr. d'Ordine No. Referenzia	Hinweis Hints Indications Indicazione Indicaciones
1	1	10001214					
2	2	25025159	DIN608-M12x80-4.6				
3	2	25025160	DIN608-M12x100-4.6				
4	4	20029004	VSK12				
5	4	25031005	DIN934-M12-8				

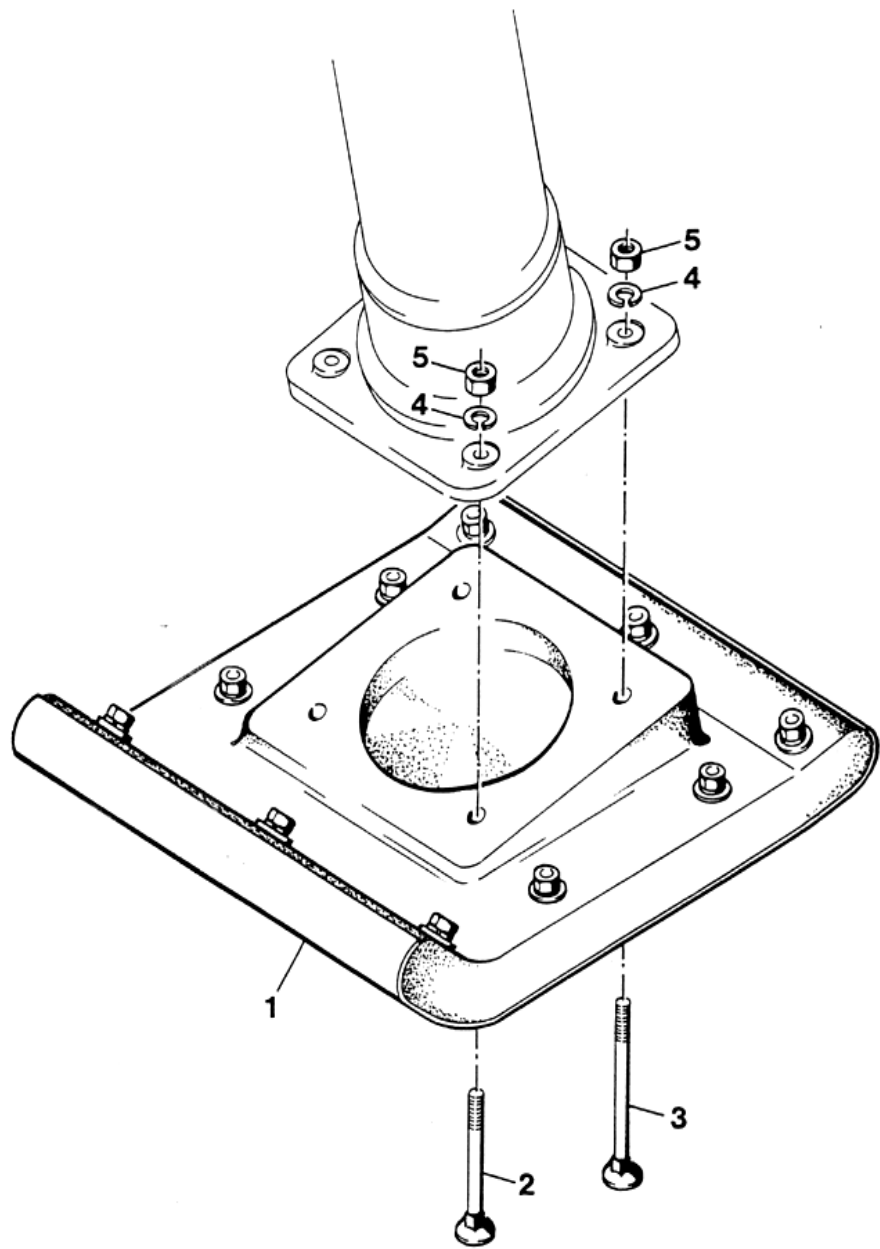

E 551-0591

E 758-0800

Position Ref.No. Repère Posizione Posicion	Menge Quantity Quantité Quantità Cantidad	Teile-Nr. Part-No. No. Référence Nr. d'Ordine No. Referenzia	Hinweis Hints Indications Indicazione Indicaciones	Position Ref. No. Repère Posizione Posicion	Menge Quantity Quantité Quantità Cantidad	Teile-Nr. Part-No. No. Référence Nr. d'Ordine No. Referenzia	Hinweis Hints Indications Indicazione Indicaciones
1	1	20001096		32	2	20022026	
2	3	25038009	DIN933-M8x30-8.8	33	1	40000235	
3	3	20029003	VSK8	34	1	20019317	
4	1	20002065		35	4	20026434	
5	1	20029001	VSK10	36	---	-----	siehe Robin-Motor
6	1	25031004	DIN934-M10-8				Ersatzteilliste
7	1	20025611					
8	1	20025614					see spare parts list for
9	2	25038008	DIN933-M8x25-8.8				Robin engine
10	2	25048002	DIN125-A8,4				
11	2	25031013	DIN985-M8-8				voir liste pièces détachées
12	1	20025612					moteur Robin
13	*	25025188	DIN988-PS14x20x0,3				
14	1	20013072					vease lista de requestos
15	2	2007056					del Motor Robin
16	1	10015751					
17	1	20025634					vedi listino ricambi motore
18	1	10016080					Robin
21	1	25040001	DIN931-M6x60-8.8				
22	1	20029007	VSK6				*) je nach Bedarf
23	1	20007007					according to requirement
24	1	20025791					selon les besoins
25	2	25047016	DIN7991-M5x16-8.8				segun necesidades
26	2	20022005					se necessario
27	1	20006057					
28	1	20025358					
29	1	25031002	DIN934-M6-8				
30	1	20008031					
31	1	30043890					

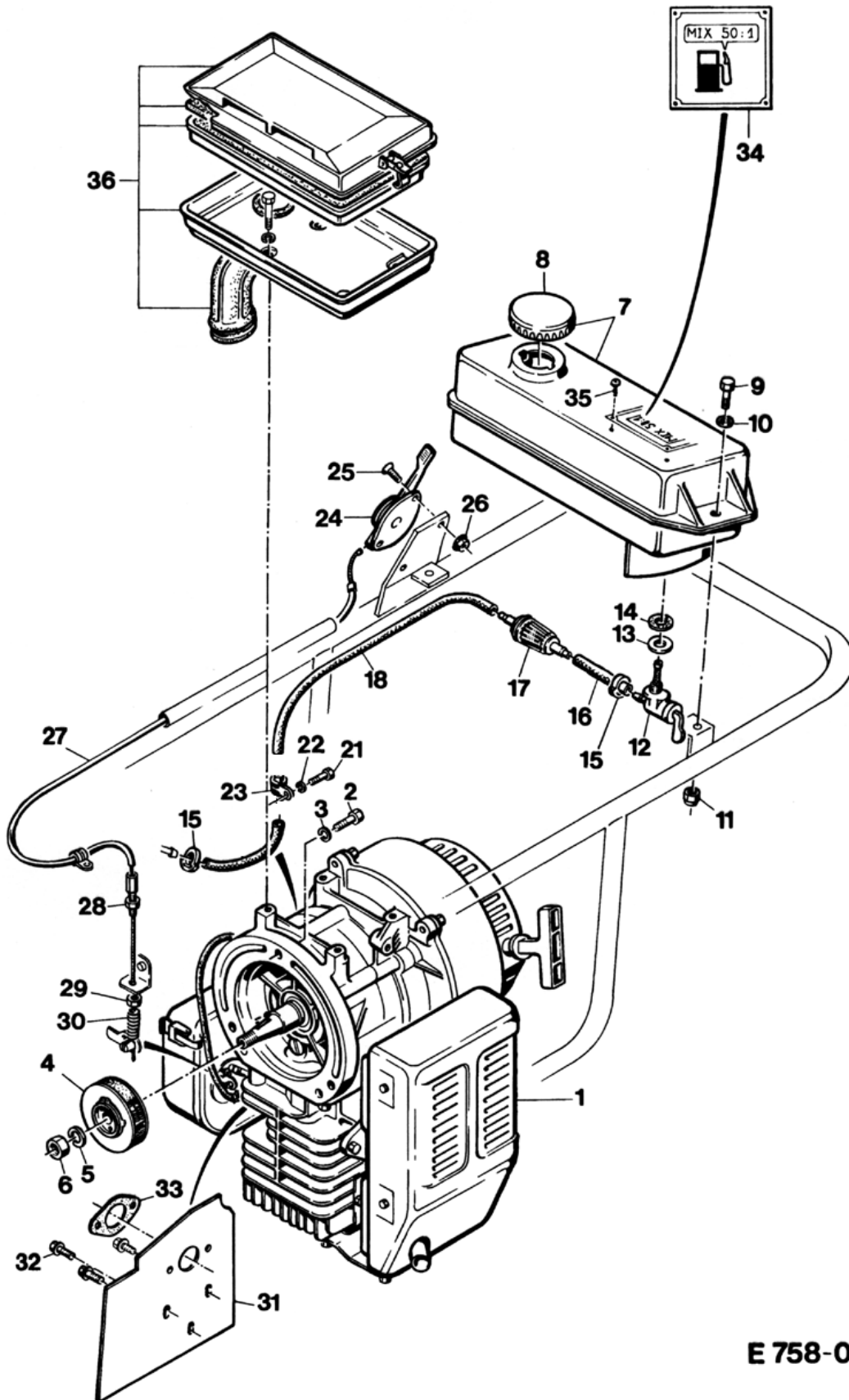

E 758-0800

E 759-0695

Position Ref.No. Repère Posizione Posicion	Menge Quantity Quantité Quantita Cantidad	Teile-Nr. Part-No. No. Référence Nr. d'Ordine No. Referenzia	Hinweis Hints Indications Indicazione Indicaciones	Position Ref. No. Repère Posizione Posicion	Menge Quantity Quantité Quantita Cantidad	Teile-Nr. Part-No. No. Référence Nr. d'Ordine No. Referenzia	Hinweis Hints Indications Indicazione Indicaciones
1	1	20002065					
2	1	20002335					
3	2	20002336					
4	2	20002337					
5	4	20002232					
6	2	20002338					
7	2	20002339					

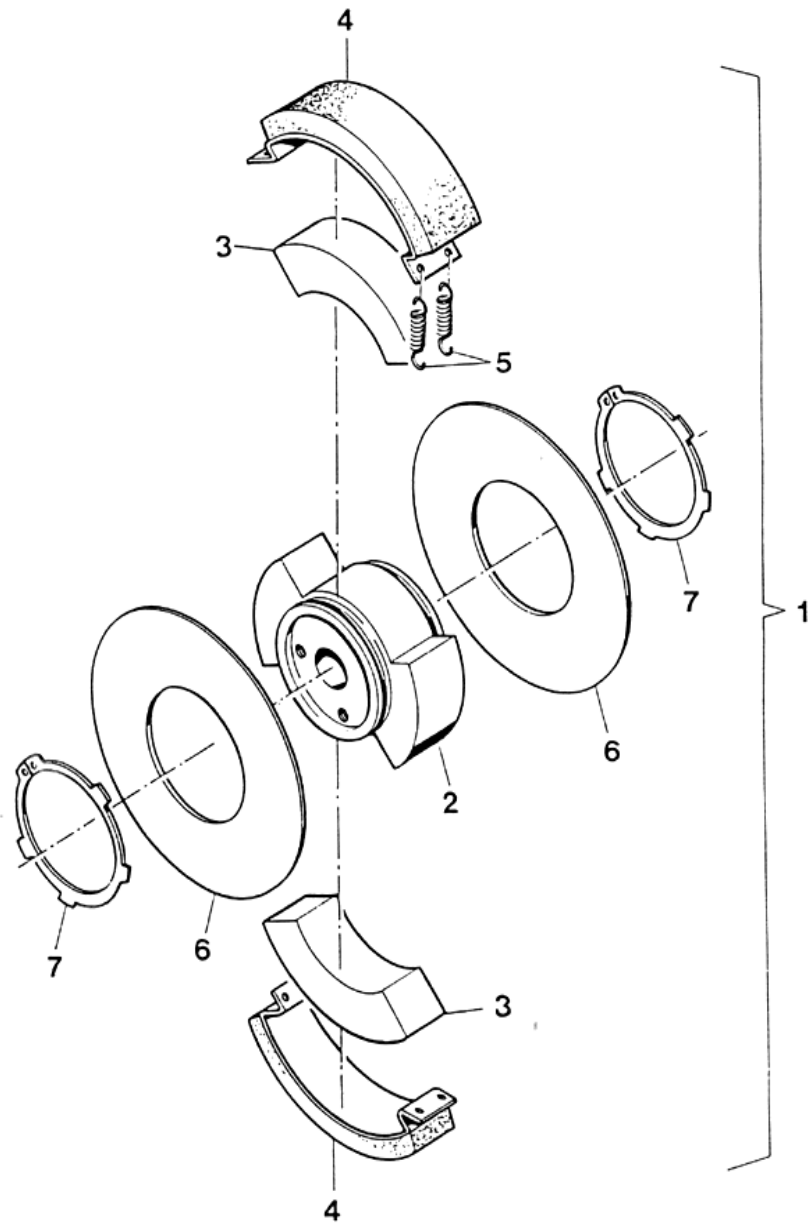

E 759-0695

E 921-0198

Position Ref.No. Repère Posizione Posicion	Menge Quantity Quantité Quantita Cantidad	Teile-Nr. Part-No. No. Référence Nr. d'Ordine No. Referenzia	Hinweis Hints Indications Indicazione Indicaciones	Position Ref. No. Repère Posizione Posicion	Menge Quantity Quantité Quantita Cantidad	Teile-Nr. Part-No. No. Référence Nr. d'Ordine No. Referenzia	Hinweis Hints Indications Indicazione Indicaciones
1	1	10022054					
2	4	25038009	DIN 933-M8x30-8.8				
3	4	20029003	VSK 8				
4	4	20022002	M8				
5	2	20004016					
6	8	25038007	DIN 933-M8x20-8.8				
7	8	20029003	VSK 8				
8	1	10022055					
9	1	20007004					
10	1	10015750					
11	1	25038007	DIN 933-M8x20-8.8				
12	1	25031013	DIN 985-M8-8				

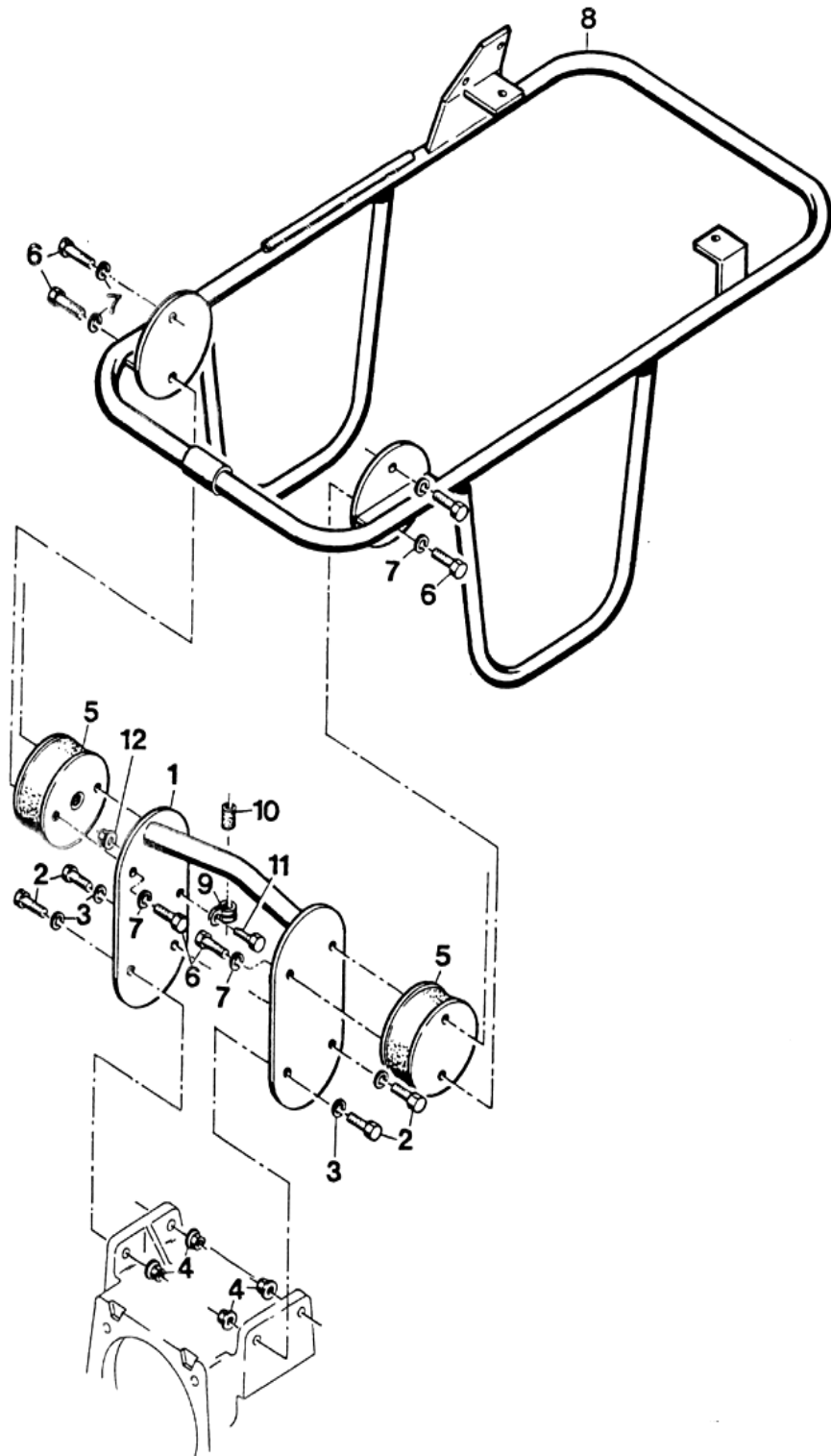

E 921-0198

E 550-0591

Position Ref.No. Repère Posizione Posicion	Menge Quantity Quantité Quantita Cantidad	Teile-Nr. Part-No. No. Référence Nr. d'Ordine No. Referenzia	Hinweis Hints Indications Indicazione Indicaciones	Position Ref. No. Repère Posizione Posicion	Menge Quantity Quantité Quantita Cantidad	Teile-Nr. Part-No. No. Référence Nr. d'Ordine No. Referenzia	Hinweis Hints Indications Indicazione Indicaciones
1	2	10003087					
2	2	25025239	DIN 608-M12x110-4.6				
3	4	25031005	DIN 934-M12-8				
4	1	10002141					
5	2	20025007					
6	2	25048006	DIN 125-A21				
7	2	25037004	DIN 94-4x40				

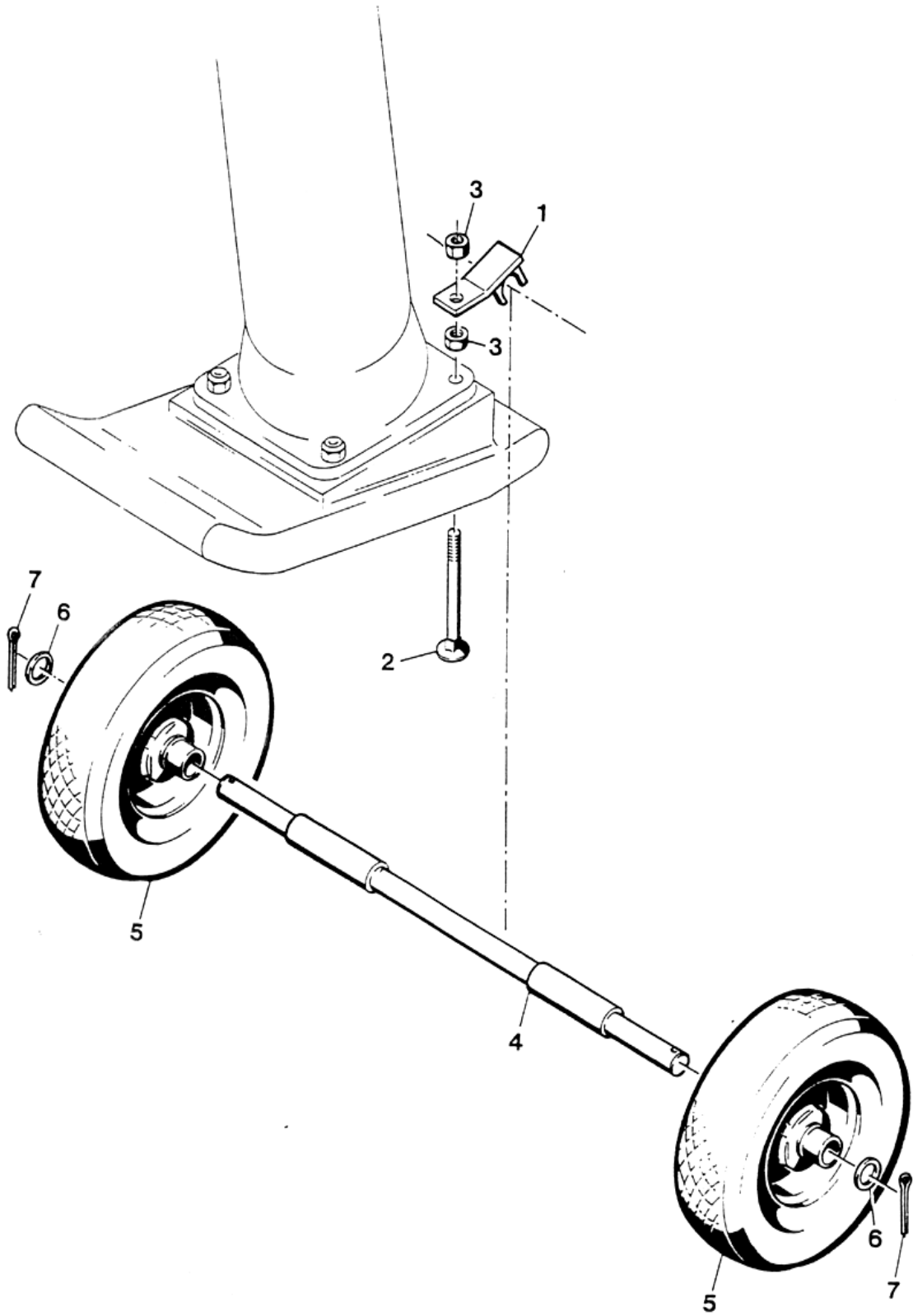

E 550-0591

For problems, questions and further information refer to one of the following addresses:

in Germany and	WEBER Maschinentechnik GmbH Postfach 2153 57329 Bad Laasphe – Rückershausen	Telefon Telefax Telefax	02754 / 398-0 switchboard 02754 / 398101 02754 / 398102 - spare parts- directlinie
In Netherlands	WEBER Machinetechniek B.V. Graafschap Hornelaan 159 6001 AC Weert	Telefon Telefax	0495 / 530215 0495 / 541839
in France	WEBER Technologie S.a.r.l. 26, rue d'Arsonval 69680 Chassieu	Telefon Telefax	04.72.79.10.20 04.72.79.10.21
in Poland	WEBER Maschinentechnik SP. ZO.O. ul. Grodziska 7 05-830 Stara Wies / Nadarzyn	Telefon Telefax	22 / 739 70 – 80 22 / 739 70 – 81 22 / 739 70 - 82
in USA und Canada	WEBER Machine (USA), Inc. 40 Johnson Ave 112 Bangor, ME 04401	Telefon Telefax	207 / 947 / 4990 207 / 947 / 5452
in South - America	WEBER Maschinentechnik do Brasil Ltda. Rua Sete de Setembro, 275 93332-470 Novo Hamburgo-RS	Telefon Telefax	0055 - 51 - 587 3044 0055 - 51 - 587 2271

